

# SN54LS137, SN74LS137 3-LINE TO 8-LINE DECODERS/DEMULTIPLEXERS WITH ADDRESS LATCHES

SDLS132 - JUNE 1978 - REVISED MARCH 1988

- Combines Decoder and 3-Bit Address Latch
- Incorporates 2 Enable Inputs to Simplify Cascading
- Low Power Dissipation . . . 65 mW Typ

### description

The 'LS137 is a three-line to eight-line decoder/demultiplexer with latches on the three address inputs. When the latch-enable input ( $\overline{GL}$ ) is low, the 'LS137 acts as a decoder/demultiplexer. When  $\overline{GL}$  goes from low to high, the address present at the select inputs (A, B, and C) is stored in the latches. Further address changes are ignored as long as  $\overline{GL}$  remains high. The output enable controls, G1 and  $\overline{G2}$ , control the state of the outputs independently of the select or latch-enable inputs. All of the outputs are high unless G1 is high and  $\overline{G2}$  is low. The 'LS137 is ideally suited for implementing glitch-free decoders in strobed (stored-address) applications in bus-oriented systems.

SN54LS137 . . . J OR W PACKAGE

SN74LS137 . . . D OR N PACKAGE

(TOP VIEW)

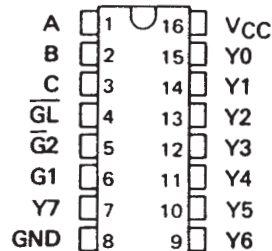

SN54LS137 . . .FK PACKAGE

(TOP VIEW)

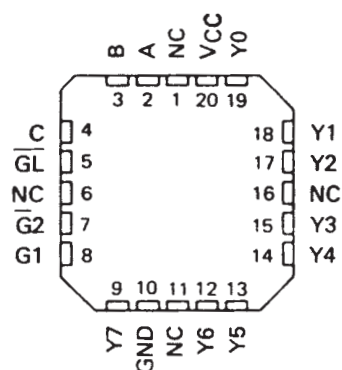

NC - No internal connection

### schematics of inputs and outputs

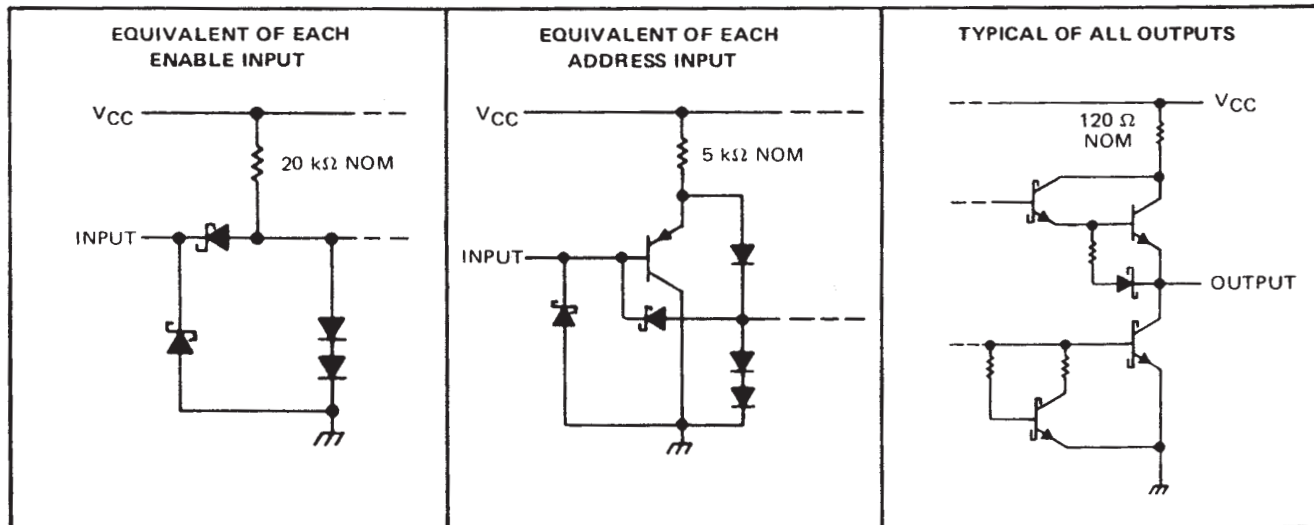

PRODUCTION DATA information is current as of publication date. Products conform to specifications per the terms of Texas Instruments standard warranty. Production processing does not necessarily include testing of all parameters.



POST OFFICE BOX 655303 • DALLAS, TEXAS 75265

Copyright © 1988, Texas Instruments Incorporated

# SN54LS137, SN74LS137 3-LINE TO 8-LINE DECODERS/DEMULTIPLEXERS WITH ADDRESS LATCHES

SDLS132 – JUNE 1978 – REVISED MARCH 1988

## logic symbols†

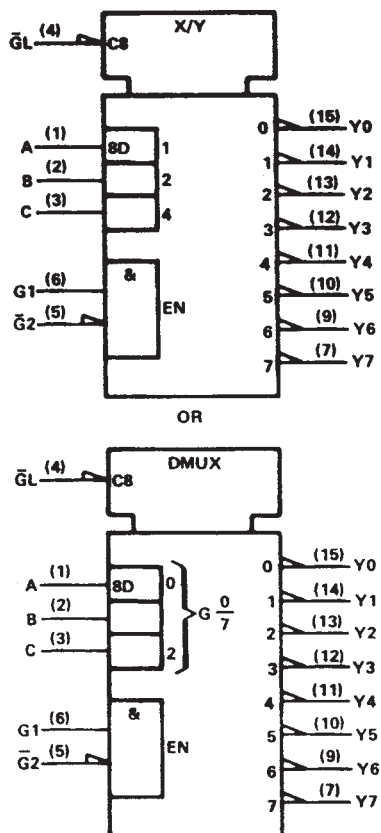

FUNCTION TABLE

INPUTS				OUTPUTS									
ENABLE		SELECT											
GL	G1	G2	C	B	A	Y0	Y1	Y2	Y3	Y4	Y5	Y6	Y7
X	X	H	X	X	X	H	H	H	H	H	H	H	H
X	L	X	X	X	X	H	H	H	H	H	H	H	H
L	H	L	L	L	L	L	H	H	H	H	H	H	H
L	H	L	L	L	H	H	L	H	H	H	H	H	H
L	H	L	L	H	H	H	H	L	H	H	H	H	H
L	H	L	H	L	L	H	H	H	H	L	H	H	H
L	H	L	H	L	H	H	H	H	H	H	L	H	H
L	H	L	H	H	L	H	H	H	H	H	H	L	H
L	H	L	H	H	H	H	H	H	H	H	H	H	L
H	H	L	X	X	X	Output corresponding to stored address, L; all others, H							

H = high level, L = low level, X = irrelevant

†These symbols are in accordance with ANSI/IEEE Std 91-1984 and IEC Publication 617-12.

Pin numbers shown are for D, J, N, and W packages.

# SN54LS137, SN74LS137 3-LINE TO 8-LINE DECODERS/DEMULTIPLEXERS WITH ADDRESS LATCHES

SDLS132 – JUNE 1978 – REVISED MARCH 1988

logic diagram (positive logic)

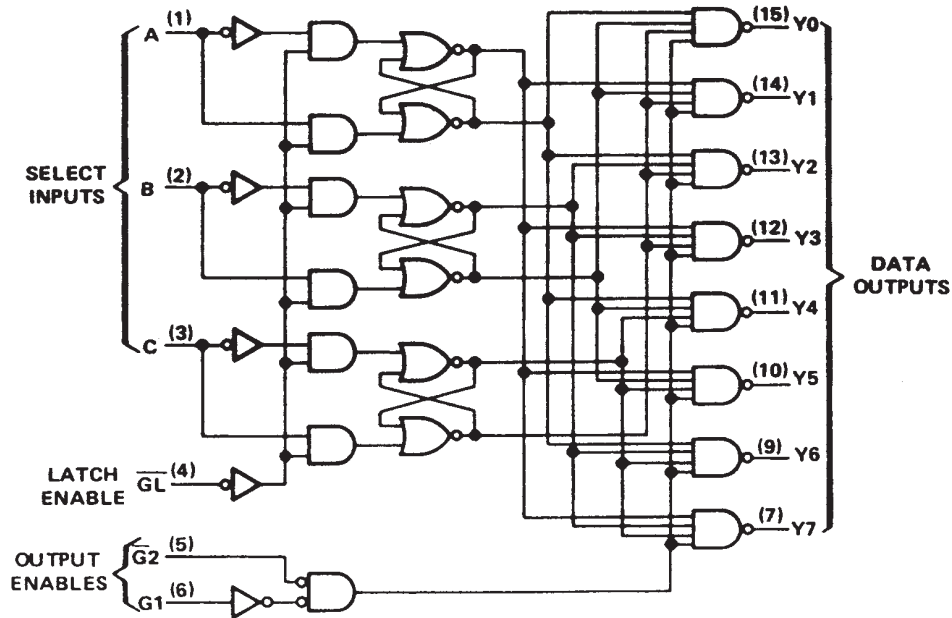

Pin numbers shown are for D, J, N, and W packages.

### absolute maximum ratings over operating free-air temperature range (unless otherwise noted)

Supply voltage, $V_{CC}$ (See Note 1)	7 V
Input voltage	7 V
Operating free-air temperature range: SN54LS137	$-55^{\circ}\text{C}$ to $125^{\circ}\text{C}$
SN74LS137	$0^{\circ}\text{C}$ to $70^{\circ}\text{C}$
Storage temperature range	$-65^{\circ}\text{C}$ to $150^{\circ}\text{C}$

NOTE 1: Voltage values are with respect to network ground terminal.

# SN54LS137, SN74LS137 3-LINE TO 8-LINE DECODERS/DEMULTIPLEXERS WITH ADDRESS LATCHES

SDLS132 – JUNE 1978 – REVISED MARCH 1988

## recommended operating conditions

	SN54LS137			SN74LS137			UNIT
	MIN	NOM	MAX	MIN	NOM	MAX	
Supply voltage, $V_{CC}$	4.5	5	5.5	4.75	5	5.25	V
High-level output current, $I_{OH}$			-400			-400	$\mu$ A
Low-level output current, $I_{OL}$			4			8	mA
Width of enabling pulse at $\overline{G_L}$ , $t_w$	15			15			ns
Setup time at A, B, and C inputs, $t_{su}$	10			10			ns
Hold time at A, B, and C inputs, $t_h$	10			10			ns
Operating free-air temperature, $T_A$	-55		125	0		70	$^{\circ}$ C

## electrical characteristics over recommended operating free-air temperature range (unless otherwise noted)

PARAMETER	TEST CONDITIONS <sup>†</sup>	SN54LS137			SN74LS137			UNIT	
		MIN	TYP <sup>‡</sup>	MAX	MIN	TYP <sup>‡</sup>	MAX		
$V_{IH}$ High-level input voltage		2			2			V	
$V_{IL}$ Low-level input voltage				0.7			0.8	V	
$V_{IK}$ Input clamp voltage	$V_{CC} = \text{MIN}$ , $I_I = -18 \text{ mA}$			-1.5			-1.5	V	
$V_{OH}$ High-level output voltage	$V_{CC} = \text{MIN}$ , $V_{IH} = 2 \text{ V}$ , $V_{IL} = V_{IL \text{ max}}$ , $I_{OH} = -400 \mu\text{A}$	2.5	3.5		2.7	3.5		V	
$V_{OL}$ Low-level output voltage	$V_{CC} = \text{MIN}$ , $V_{IH} = 2 \text{ V}$ , $V_{IL} = V_{IL \text{ max}}$			0.25	0.4		0.25	0.4	V
							0.35	0.5	
$I_I$ Input current at maximum input voltage	$V_{CC} = \text{MAX}$ , $V_I = 7 \text{ V}$			0.1			0.1	mA	
$I_{IH}$ High-level input current	$V_{CC} = \text{MAX}$ , $V_I = 2.7 \text{ V}$			20			20	$\mu$ A	
$I_{IL}$ Low-level input current	$V_{CC} = \text{MAX}$ , $V_I = 0.4 \text{ V}$							mA	
$I_{OS}$ Short-circuit output current <sup>§</sup>	$V_{CC} = \text{MAX}$	-20		-100	-20		-100	mA	
$I_{CC}$ Supply current	$V_{CC} = \text{MAX}$ , See Note 2		11	18		11	18	mA	

<sup>†</sup> For conditions shown as MIN or MAX, use the appropriate value specified under recommended operating conditions.

<sup>‡</sup> All typical values are at  $V_{CC} = 5 \text{ V}$ ,  $T_A = 25^{\circ}\text{C}$ .

<sup>§</sup> Not more than one output should be shorted at a time, and duration of the short-circuit should not exceed one second.

NOTE 2:  $I_{CC}$  is tested with all inputs grounded and all outputs open.

## switching characteristics, $V_{CC} = 5 \text{ V}$ , $T_A = 25^{\circ}\text{C}$ , see note 3

PARAMETER <sup>¶</sup>	FROM (INPUT)	TO (OUTPUT)	LEVELS OF DELAY	TEST CONDITIONS	MIN	TYP	MAX	UNIT
$t_{PLH}$	A, B, C	Y	2	$C_L = 15 \text{ pF}$ , $R_L = 2 \text{ k}\Omega$ , See Note 3		11	17	ns
$t_{PHL}$			4			25	38	
$t_{PLH}$	A, B, C	Y	3			16	24	ns
$t_{PHL}$			3			19	29	
$t_{PLH}$	Enable $\overline{G_2}$	Y	2			13	21	ns
$t_{PHL}$			2			16	27	
$t_{PLH}$	Enable G1	Y	3			14	21	ns
$t_{PHL}$			3			18	27	
$t_{PLH}$	Enable $\overline{G_L}$	Y	3			18	27	ns
$t_{PHL}$			4			25	38	

<sup>¶</sup>  $t_{PLH}$  = propagation delay time, low-to-high-level output.

$t_{PHL}$  = propagation delay time, high-to-low-level output.

NOTE 3: Load circuits and voltage waveforms are shown in Section 1.

## IMPORTANT NOTICE

Texas Instruments and its subsidiaries (TI) reserve the right to make changes to their products or to discontinue any product or service without notice, and advise customers to obtain the latest version of relevant information to verify, before placing orders, that information being relied on is current and complete. All products are sold subject to the terms and conditions of sale supplied at the time of order acknowledgement, including those pertaining to warranty, patent infringement, and limitation of liability.

TI warrants performance of its semiconductor products to the specifications applicable at the time of sale in accordance with TI's standard warranty. Testing and other quality control techniques are utilized to the extent TI deems necessary to support this warranty. Specific testing of all parameters of each device is not necessarily performed, except those mandated by government requirements.

CERTAIN APPLICATIONS USING SEMICONDUCTOR PRODUCTS MAY INVOLVE POTENTIAL RISKS OF DEATH, PERSONAL INJURY, OR SEVERE PROPERTY OR ENVIRONMENTAL DAMAGE ("CRITICAL APPLICATIONS"). TI SEMICONDUCTOR PRODUCTS ARE NOT DESIGNED, AUTHORIZED, OR WARRANTED TO BE SUITABLE FOR USE IN LIFE-SUPPORT DEVICES OR SYSTEMS OR OTHER CRITICAL APPLICATIONS. INCLUSION OF TI PRODUCTS IN SUCH APPLICATIONS IS UNDERSTOOD TO BE FULLY AT THE CUSTOMER'S RISK.

In order to minimize risks associated with the customer's applications, adequate design and operating safeguards must be provided by the customer to minimize inherent or procedural hazards.

TI assumes no liability for applications assistance or customer product design. TI does not warrant or represent that any license, either express or implied, is granted under any patent right, copyright, mask work right, or other intellectual property right of TI covering or relating to any combination, machine, or process in which such semiconductor products or services might be or are used. TI's publication of information regarding any third party's products or services does not constitute TI's approval, warranty or endorsement thereof.

This datasheet has been downloaded from:

[www.DatasheetCatalog.com](http://www.DatasheetCatalog.com)

Datasheets for electronic components.

# Texas Instruments

<http://www.ti.com>

This file is the datasheet for the following electronic components:

SN74LS137 - <http://www.ti.com/product/sn74ls137?HQS=TI-null-null-dscatalog-df-pf-null-wwe>

SN74LS137D - <http://www.ti.com/product/sn74ls137d?HQS=TI-null-null-dscatalog-df-pf-null-wwe>

SN74LS137N - <http://www.ti.com/product/sn74ls137n?HQS=TI-null-null-dscatalog-df-pf-null-wwe>

SN54LS137FK - <http://www.ti.com/product/sn54ls137fk?HQS=TI-null-null-dscatalog-df-pf-null-wwe>

74LS137 - <http://www.ti.com/product/74ls137?HQS=TI-null-null-dscatalog-df-pf-null-wwe>

SN54LS137W - <http://www.ti.com/product/sn54ls137w?HQS=TI-null-null-dscatalog-df-pf-null-wwe>



LittleDiode supplies new, hard to find or obsolete electronic components and semiconductors all over the world.

With over two million different components listed you are sure to find the part you need.

Feel free to visit us today at our online store:

[LittleDiode.com](http://LittleDiode.com)

Looking forward to providing you with the best possible service.