



N-CHANNEL MOS FIELD EFFECT POWER TRANSISTOR

2SK773

DESCRIPTION The 2SK773 is N-channel MOD Field Effect Power Transistor designed for switching power supplies DC-DC converters.

- FEATURES**
- Suitable for switching power supplies, actuator controls, and pulse circuits.
 - Low $R_{DS(on)}$
 - No second breakdown

ABSOLUTE MAXIMUM RATINGS

Maximum Temperatures

Storage Temperature -55 to +150 °C

Channel Temperature 150 °C Maximum

Maximum Power Dissipation ($T_C = 25\text{ °C}$)

Total Power Dissipation 120 W

Maximum Voltages and Currents ($T_a = 25\text{ °C}$)

V_{DSS} Drain to Source Voltage 500 V

V_{GSS} Gate to Source Voltage ±20 V

$I_{D(DC)}$ Drain Current (DC) ±12 A

$I_D(\text{pulse})$ Drain Current (pulse)* ±40 A

* $PW \leq 100\ \mu s$, Duty Cycle $\leq 2\%$

PACKAGE DIMENSIONS
in millimeters (inches)

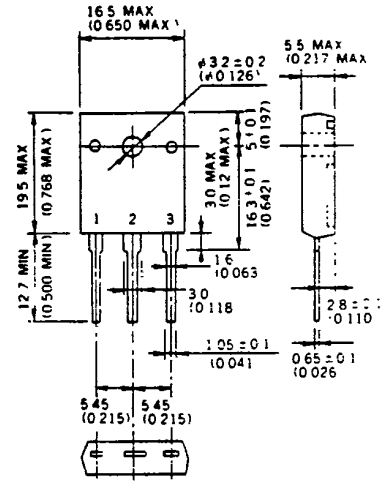

1. Gate
2. Drain (Fin)
3. Source

ELECTRICAL CHARACTERISTICS ($T_a = 25\text{ °C}$)

SYMBOL	CHARACTERISTIC	MIN.	TYP.	MAX.	UNIT	TEST CONDITIONS
I_{DSS}	Drain Leakage Current			100	μA	$V_{DS} = 500\text{ V}$, $V_{GS} = 0$
I_{GSS}	Gate to Source Leakage Current			±100	nA	$V_{GS} = \pm 20\text{ V}$, $V_{DS} = 0$
$V_{GS(off)}$	Gate to Source Cutoff Voltage	1.5		3.5	V	$V_{DS} = 10\text{ V}$, $I_D = 1\text{ mA}$
$ Y_{fs} $	Forward Transfer Admittance	5.0			S	$V_{DS} = 10\text{ V}$, $I_D = 6\text{ A}$
$R_{DS(on)}$	Drain to Source On-State Resistance		0.47	0.60	Ω	$V_{GS} = 10\text{ V}$, $I_D = 6\text{ A}$
C_{iss}	Input Capacitance		2200		pF	
C_{oss}	Output Capacitance		480		pF	$V_{DS} = 10\text{ V}$, $V_{GS} = 0$, $f = 1\text{ MHz}$
C_{rss}	Reverse Transfer Capacitance		130		pF	
$t_{d(on)}$	Turn-On Delay Time		30		ns	$I_D = 6\text{ A}$, $V_{CC} \approx 150\text{ V}$
t_r	Rise Time		45		ns	$V_{GS(on)} = 10\text{ V}$
$t_{d(off)}$	Turn-Off Delay Time		120		ns	$R_L = 25\ \Omega$
t_f	Fall Time		45		ns	$R_{in} = 10\ \Omega$

TYPICAL CHARACTERISTICS ($T_a = 25^\circ\text{C}$)

98 DE 6427525 0018923 4

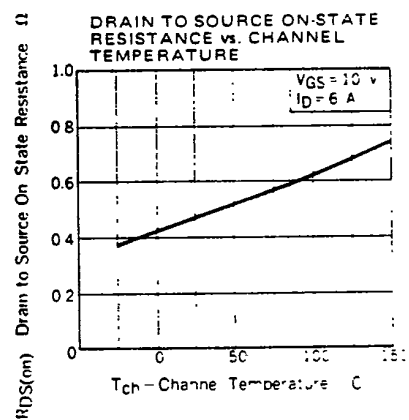
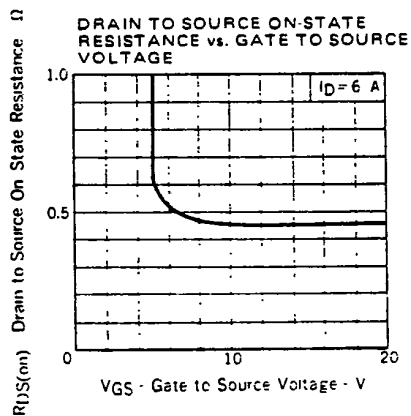
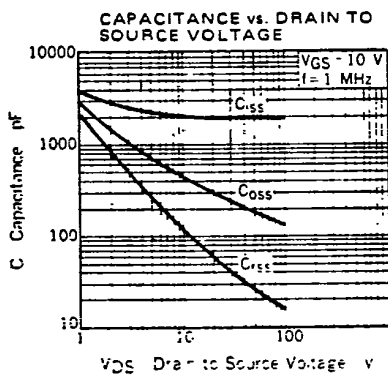
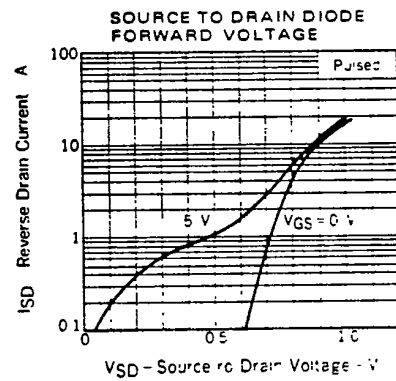
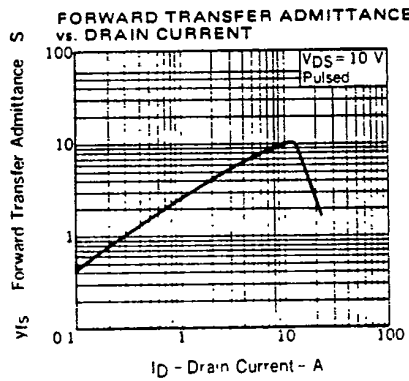
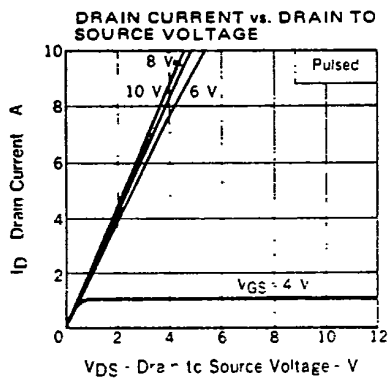
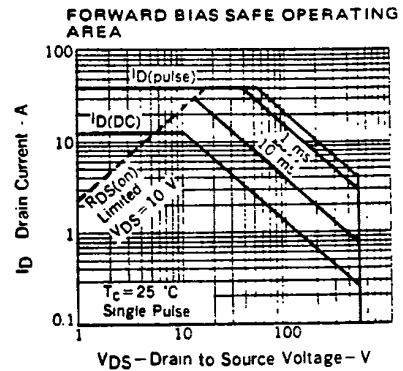
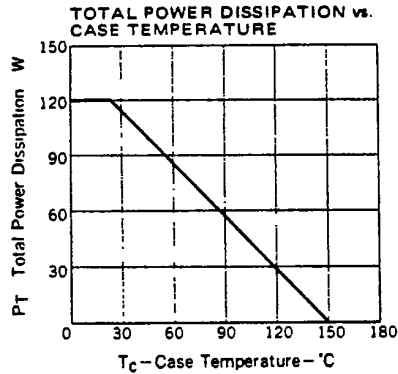
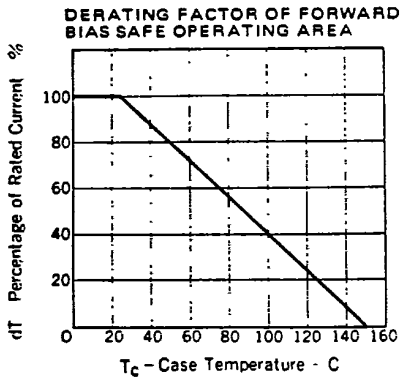

NEC

6427525

98 DE 6427525 0018924 6

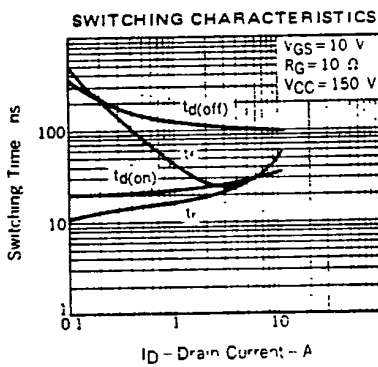
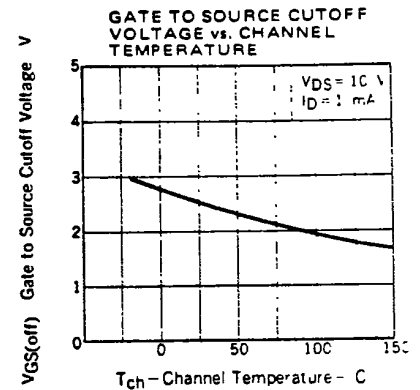
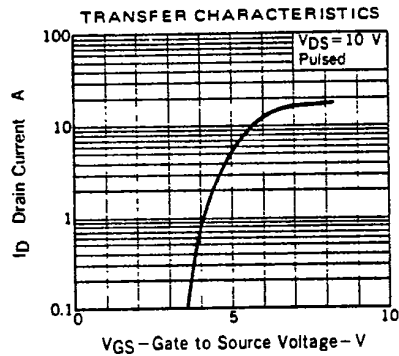
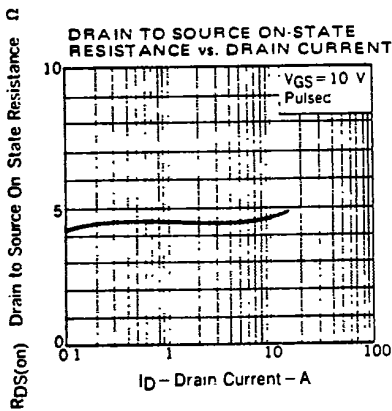

SWITCHING TIME TEST CIRCUIT

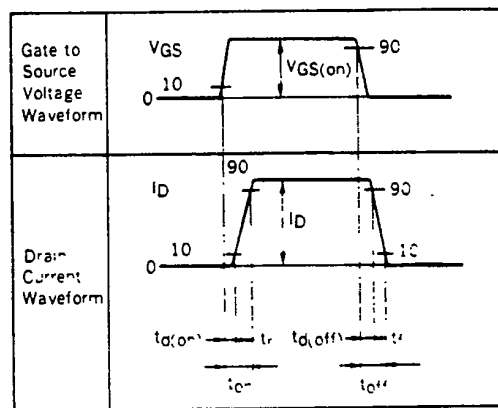
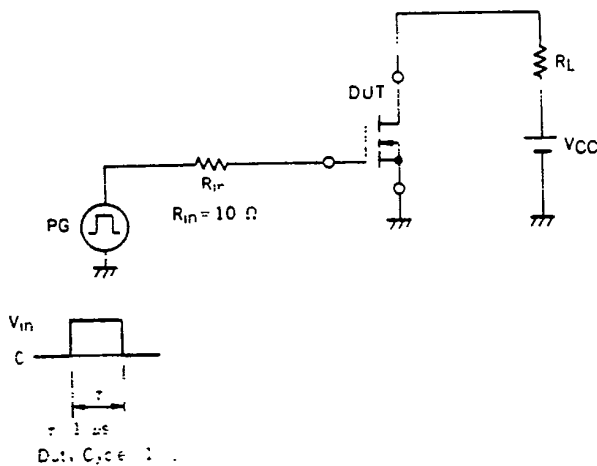

This datasheet has been downloaded from:

www.DatasheetCatalog.com

Datasheets for electronic components.



LittleDiode supplies new, hard to find or obsolete electronic components and semiconductors all over the world.

With over two million different components listed you are sure to find the part you need.

Feel free to visit us today at our online store:

LittleDiode.com

Looking forward to providing you with the best possible service.