

## 54LS283/DM54LS283/DM74LS283 4-Bit Binary Adders with Fast Carry

### General Description

These full adders perform the addition of two 4-bit binary numbers. The sum ( $\Sigma$ ) outputs are provided for each bit and the resultant carry ( $C_4$ ) is obtained from the fourth bit. These adders feature full internal look ahead across all four bits. This provides the system designer with partial look-ahead performance at the economy and reduced package count of a ripple-carry implementation.

The adder logic, including the carry, is implemented in its true form meaning that the end-around carry can be accomplished without the need for logic or level inversion.

### Features

- Full-carry look-ahead across the four bits
- Systems achieve partial look-ahead performance with the economy of ripple carry
- Typical add times
  - Two 8-bit words 25 ns
  - Two 16-bit words 45 ns
- Typical power dissipation per 4-bit adder 95 mW
- Alternate Military/Aerospace device (54LS283) is available. Contact a National Semiconductor Sales Office/Distributor for specifications.

### Connection Diagram

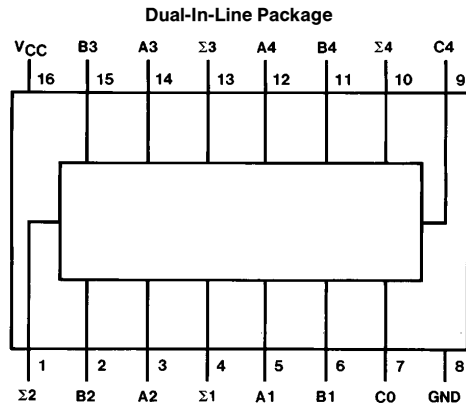

TL/F/6421-1

Order Number 54LS283DMQB, 54LS283FMQB, 54LS283LMQB,  
DM54LS283J, DM54LS283W, DM74LS283M or DM74LS283N  
See NS Package Number E20A, J16A, M16A, N16E or W16A

## Absolute Maximum Ratings (Note)

If Military/Aerospace specified devices are required, please contact the National Semiconductor Sales Office/Distributors for availability and specifications.

Supply Voltage	7V
Input Voltage	7V
Operating Free Air Temperature Range	
DM54LS and 54LS	–55°C to +125°C
DM74LS	0°C to +70°C
Storage Temperature Range	–65°C to +150°C

Note: The “Absolute Maximum Ratings” are those values beyond which the safety of the device cannot be guaranteed. The device should not be operated at these limits. The parametric values defined in the “Electrical Characteristics” table are not guaranteed at the absolute maximum ratings. The “Recommended Operating Conditions” table will define the conditions for actual device operation.

## Recommended Operating Conditions

Symbol	Parameter	DM54LS283			DM74LS283			Units
		Min	Nom	Max	Min	Nom	Max	
V <sub>CC</sub>	Supply Voltage	4.5	5	5.5	4.75	5	5.25	V
V <sub>IH</sub>	High Level Input Voltage	2			2			V
V <sub>IL</sub>	Low Level Input Voltage			0.7			0.8	V
I <sub>OH</sub>	High Level Output Current			–0.4			–0.4	mA
I <sub>OL</sub>	Low Level Output Current			4			8	mA
T <sub>A</sub>	Free Air Operating Temperature	–55		125	0		70	°C

## Electrical Characteristics over recommended operating free air temperature range (unless otherwise noted)

Symbol	Parameter	Conditions	Min	Typ (Note 1)	Max	Units
V <sub>I</sub>	Input Clamp Voltage	V <sub>CC</sub> = Min, I <sub>I</sub> = –18 mA			–1.5	V
V <sub>OH</sub>	High Level Output Voltage	V <sub>CC</sub> = Min, I <sub>OH</sub> = Max V <sub>IL</sub> = Max, V <sub>IH</sub> = Min	DM54	2.5	3.4	V
			DM74	2.7	3.4	
V <sub>OL</sub>	Low Level Output Voltage	V <sub>CC</sub> = Min, I <sub>OL</sub> = Max V <sub>IL</sub> = Max, V <sub>IH</sub> = Min	DM54	0.25	0.4	V
			DM74	0.35	0.5	
		I <sub>OL</sub> = 4 mA, V <sub>CC</sub> = Min	DM74	0.25	0.4	
I <sub>I</sub>	Input Current @ Max Input Voltage	V <sub>CC</sub> = Max V <sub>I</sub> = 7V	A, B		0.2	mA
			C0		0.1	
I <sub>IH</sub>	High Level Input Current	V <sub>CC</sub> = Max V <sub>I</sub> = 2.7V	A, B		40	μA
			C0		20	
I <sub>IL</sub>	Low Level Input Current	V <sub>CC</sub> = Max V <sub>I</sub> = 0.4V	A, B		–0.8	mA
			C0		–0.4	
I <sub>OS</sub>	Short Circuit Output Current	V <sub>CC</sub> = Max (Note 2)	DM54	–20	–100	mA
			DM74	–20	–100	
I <sub>CC1</sub>	Supply Current	V <sub>CC</sub> = Max (Note 3)		19	34	mA
I <sub>CC2</sub>	Supply Current	V <sub>CC</sub> = Max (Note 4)		22	39	mA

Note 1: All typicals are at V<sub>CC</sub> = 5V, T<sub>A</sub> = 25°C.

Note 2: Not more than one output should be shorted at a time, and the duration should not exceed one second.

Note 3: I<sub>CC1</sub> is measured with all outputs open, all B inputs low and all other inputs at 4.5V, or all inputs at 4.5V.

Note 4: I<sub>CC2</sub> is measured with all outputs open and all inputs grounded.



Logic Diagram

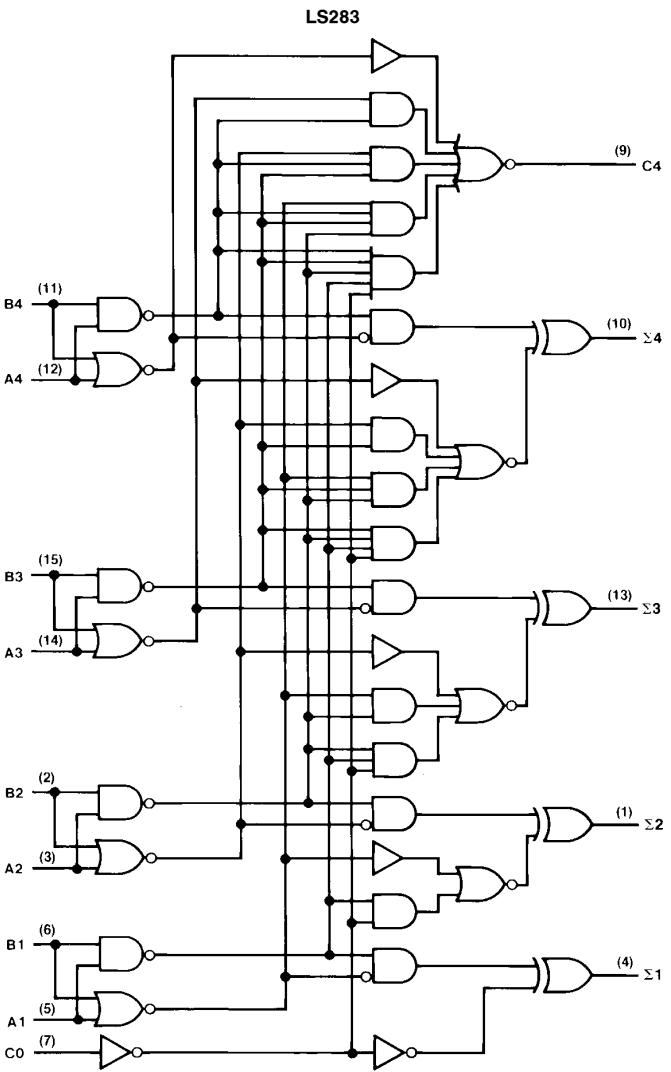

TL/F/6421-2

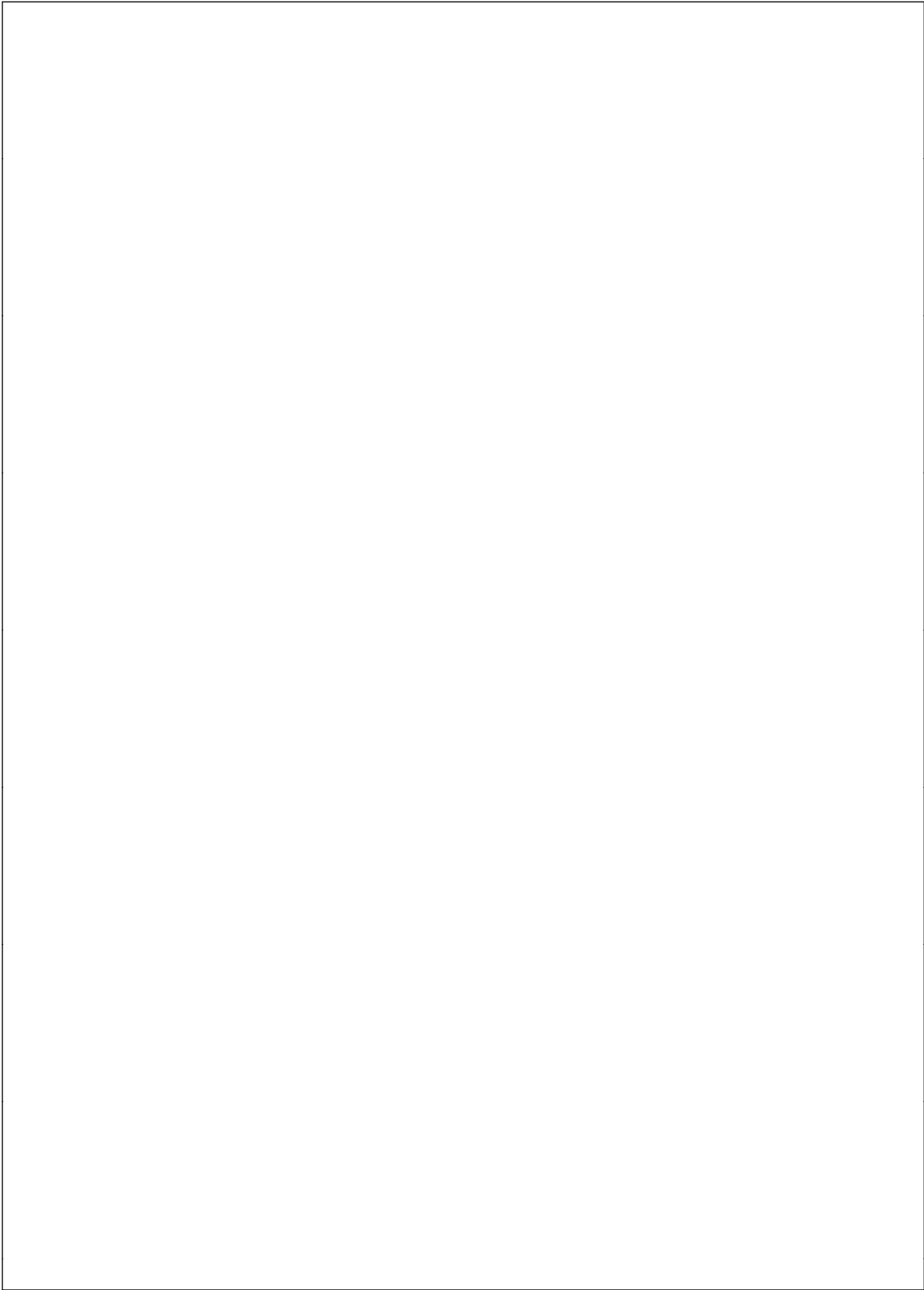

**Physical Dimensions** inches (millimeters)

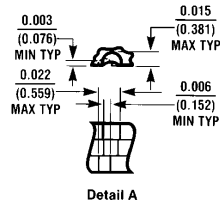
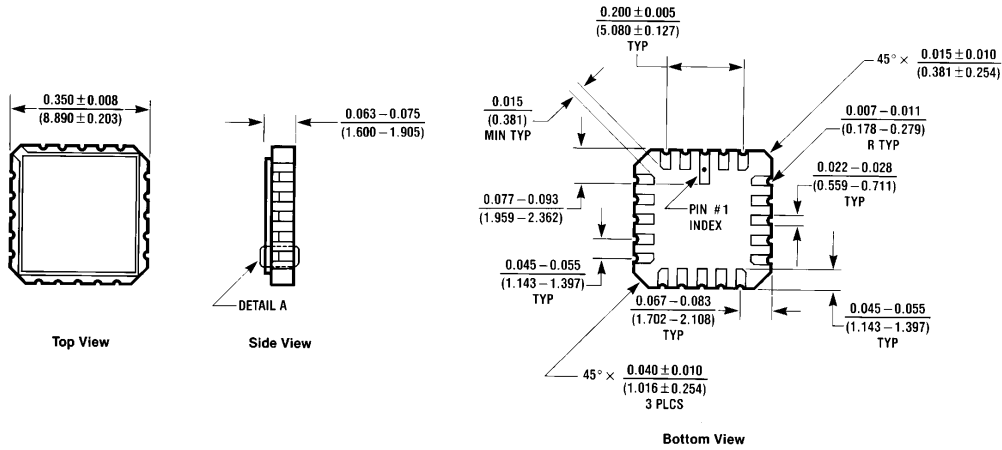

**Ceramic Leadless Chip Carrier Package (E)**  
**Order Number 54LS283LMQB**  
**NS Package Number E20A**

E20A (REV D)

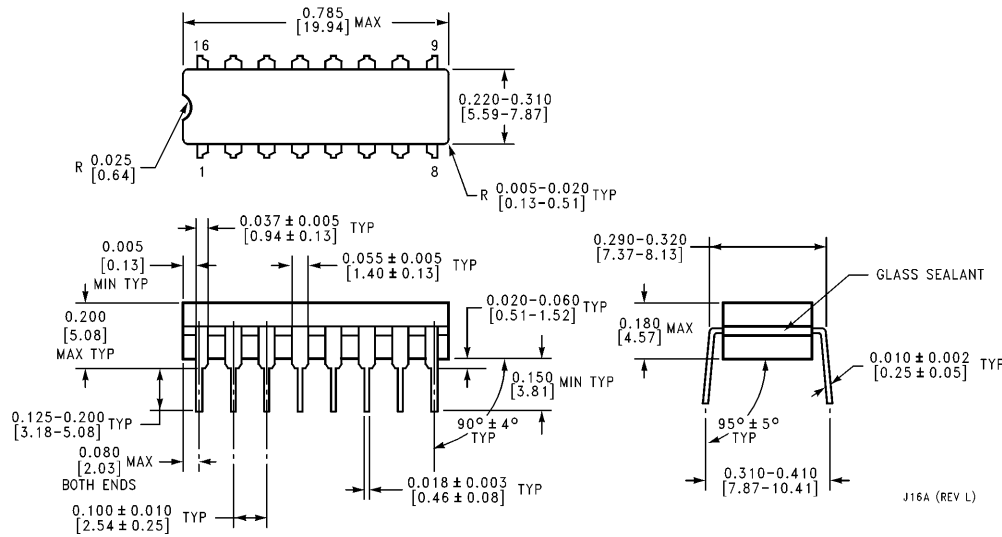

**16-Lead Ceramic Dual-In-Line Package (J)**  
**Order Number 54LS283DMQB or DM54LS283J**  
**NS Package Number J16A**

J16A (REV L)



**Physical Dimensions** inches (millimeters) (Continued)

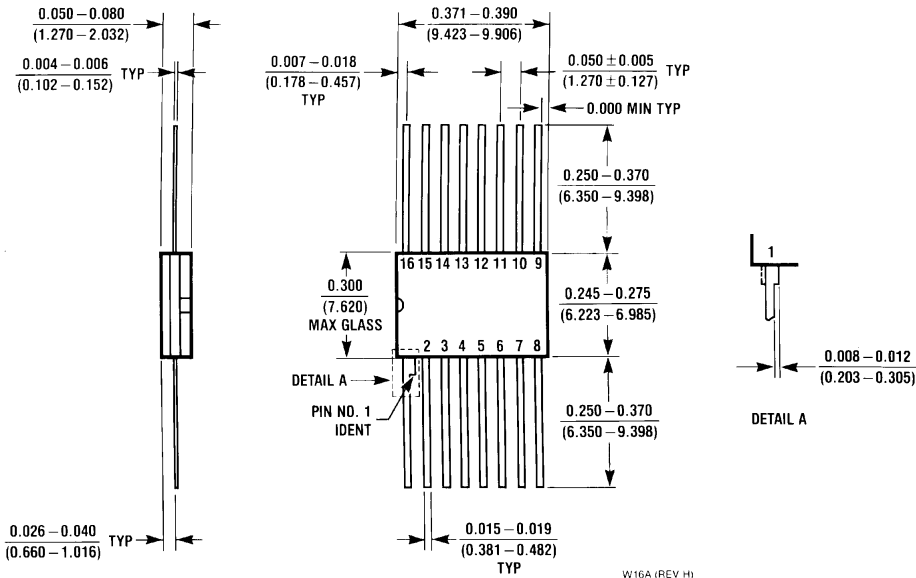

**16-Lead Ceramic Flat Package (W)**  
**Order Number 54LS283FMQB or DM54LS283W**  
**NS Package Number W16A**

**LIFE SUPPORT POLICY**

NATIONAL'S PRODUCTS ARE NOT AUTHORIZED FOR USE AS CRITICAL COMPONENTS IN LIFE SUPPORT DEVICES OR SYSTEMS WITHOUT THE EXPRESS WRITTEN APPROVAL OF THE PRESIDENT OF NATIONAL SEMICONDUCTOR CORPORATION. As used herein:

1. Life support devices or systems are devices or systems which, (a) are intended for surgical implant into the body, or (b) support or sustain life, and whose failure to perform, when properly used in accordance with instructions for use provided in the labeling, can be reasonably expected to result in a significant injury to the user.
2. A critical component is any component of a life support device or system whose failure to perform can be reasonably expected to cause the failure of the life support device or system, or to affect its safety or effectiveness.



**National Semiconductor Corporation**  
 1111 West Bardin Road  
 Arlington, TX 76017  
 Tel: 1(800) 272-9959  
 Fax: 1(800) 737-7018

**National Semiconductor Europe**  
 Fax: (+49) 0-180-530 85 86  
 Email: onjwge@tevm2.nsc.com  
 Deutsch Tel: (+49) 0-180-530 85 85  
 English Tel: (+49) 0-180-532 78 32  
 Français Tel: (+49) 0-180-532 93 58  
 Italiano Tel: (+49) 0-180-534 16 80

**National Semiconductor Hong Kong Ltd.**  
 13th Floor, Straight Block,  
 Ocean Centre, 5 Canton Rd.  
 Tsimshatsui, Kowloon  
 Hong Kong  
 Tel: (852) 2737-1600  
 Fax: (852) 2736-9960

**National Semiconductor Japan Ltd.**  
 Tel: 81-043-299-2309  
 Fax: 81-043-299-2408

National does not assume any responsibility for use of any circuitry described, no circuit patent licenses are implied and National reserves the right at any time without notice to change said circuitry and specifications.

This datasheet has been downloaded from:

[www.DatasheetCatalog.com](http://www.DatasheetCatalog.com)

Datasheets for electronic components.

# National Semiconductor was acquired by Texas Instruments.

[http://www.ti.com/corp/docs/investor\\_relations/pr\\_09\\_23\\_2011\\_national\\_semiconductor.html](http://www.ti.com/corp/docs/investor_relations/pr_09_23_2011_national_semiconductor.html)

This file is the datasheet for the following electronic components:

DM54LS283W - <http://www.ti.com/product/dm54ls283w?HQS=TI-null-null-dscatalog-df-pf-null-wwe>

74LS283 - <http://www.ti.com/product/74ls283?HQS=TI-null-null-dscatalog-df-pf-null-wwe>

DM54LS283J - <http://www.ti.com/product/dm54ls283j?HQS=TI-null-null-dscatalog-df-pf-null-wwe>

74283 - <http://www.ti.com/product/74283?HQS=TI-null-null-dscatalog-df-pf-null-wwe>



LittleDiode supplies new, hard to find or obsolete electronic components and semiconductors all over the world.

With over two million different components listed you are sure to find the part you need.

Feel free to visit us today at our online store:

[LittleDiode.com](http://LittleDiode.com)

Looking forward to providing you with the best possible service.