

5A SWITCHING REGULATOR

- 5A OUTPUT CURRENT
- 5.1V TO 40V OUTPUT VOLTAGE RANGE
- 0 TO 90% DUTY CYCLE RANGE
- INTERNAL FEED-FORWARD LINE REGULATION
- INTERNAL CURRENT LIMITING
- PRECISE 5.1V ± 2% ON CHIP REFERENCE
- RESET AND POWER FAIL FUNCTIONS
- SOFT START
- INPUT/OUTPUT SYNC PIN
- UNDER VOLTAGE LOCK OUT WITH HYSTERETIC TURN-ON
- PWM LATCH FOR SINGLE PULSE PER PERIOD
- VERY HIGH EFFICIENCY
- SWITCHING FREQUENCY UP TO 500KHZ
- THERMAL SHUTDOWN
- CONTINUOUS MODE OPERATION

DESCRIPTION

The L4975A is a stepdown monolithic power switching regulator delivering 5A at a voltage variable from 5.1 to 40V.

BLOCK DIAGRAM

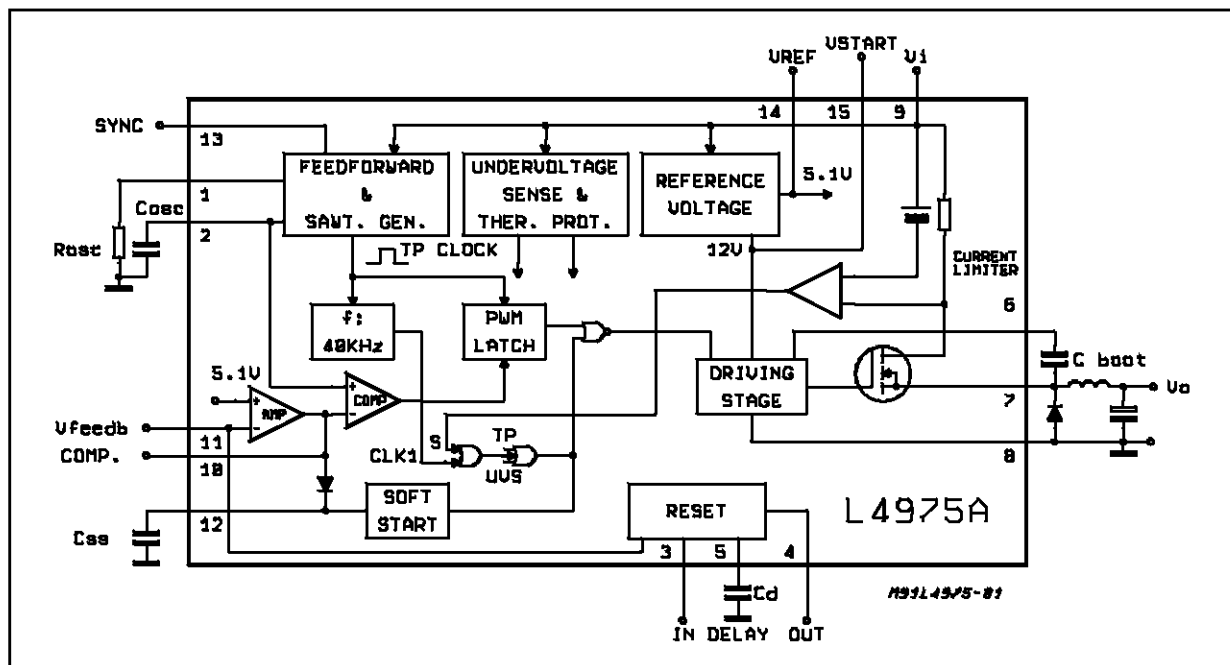

MULTIPOWER BCD TECHNOLOGY

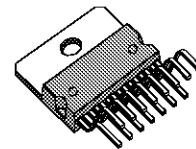

Multiwatt15V
ORDERING NUMBER: L4975A

Realized with BCD mixed technology, the device uses a DMOS output transistor to obtain very high efficiency and very fast switching times. Features of the L4975A include reset and power fail for microprocessors, feed forward line regulation, soft start, limiting current and thermal protection. The device is mounted in a 15-lead multiwatt plastic power package and requires few external components. Efficient operation at switching frequencies up to 500KHz allows reduction in the size and cost of external filter components.

L4975A

ABSOLUTE MAXIMUM RATINGS

Symbol	Parameter	Value	Unit
V ₉	Input Voltage	55	V
V ₉	Input Operating Voltage	50	V
V ₇	Output DC Voltage	-1	V
	Output Peak Voltage at t = 0.1μs f = 200KHz	-7	V
I ₇	Maximum Output Current	Internally Limited	
V ₆	Bootstrap Voltage	65	V
	Bootstrap Operating Voltage	V ₉ + 15	V
V ₃ , V ₁₂	Input Voltage at Pins 3, 12	12	V
V ₄	Reset Output Voltage	50	V
I ₄	Reset Output Sink Current	50	mA
V ₅ , V ₁₀ , V ₁₁ , V ₁₃	Input Voltage at Pin 5, 10, 11, 13	7	V
I ₅	Reset Delay Sink Current	30	mA
I ₁₀	Error Amplifier Output Sink Current	1	A
I ₁₂	Soft Start Sink Current	30	mA
P _{tot}	Total Power Dissipation at T _{case} < 120°C	30	W
T _j , T _{stg}	Junction and Storage Temperature	-40 to 150	°C

PIN CONNECTION (Top view)

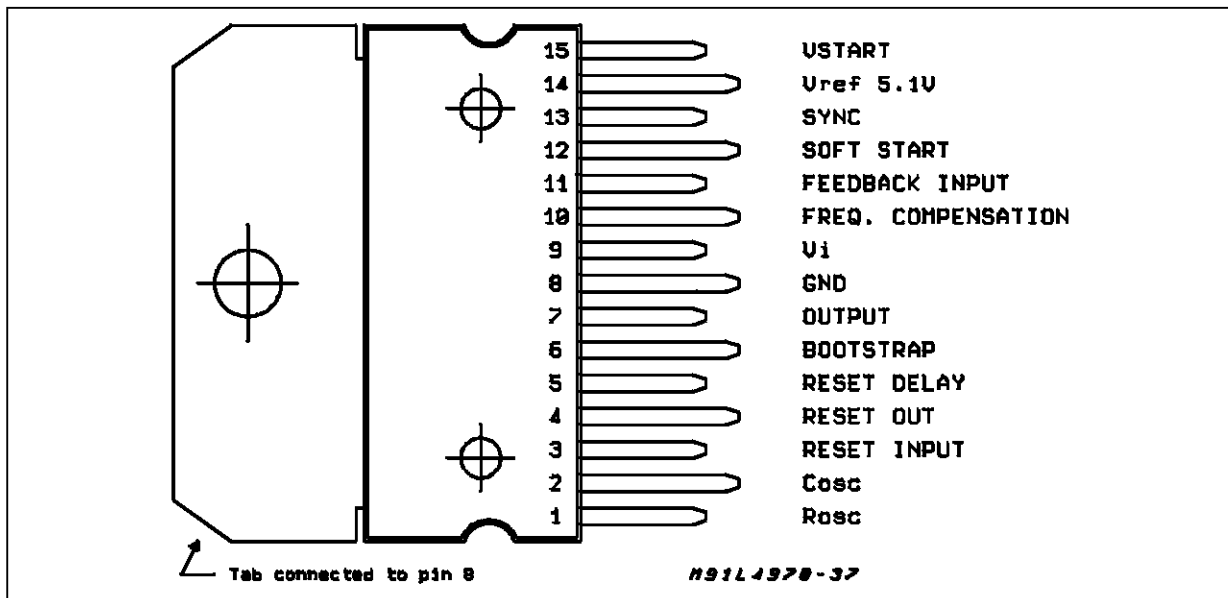

THERMAL DATA

Symbol	Parameter	Value	Unit
R _{th j-case}	Thermal Resistance Junction-case	1	°C/W
R _{th j-amb}	Thermal Resistance Junction-ambient	35	°C/W

PIN FUNCTIONS

N°	Name	Function
1	OSCILLATOR	R_{osc} . External resistor connected to ground determines the constant charging current of C_{osc} .
2	OSCILLATOR	C_{osc} . External capacitor connected to ground determines (with R_{osc}) the switching frequency.
3	RESET INPUT	Input of Power Fail Circuit. The threshold is 5.1V. It may be connected via a divider to the input for power fail function. It must be connected to the pin 14 an external 30K Ω resistor when power fail signal not required.
4	RESET OUT	Open Collector Reset/power Fail Signal Output. This output is high when the supply and the output voltages are safe.
5	RESET DELAY	A C_d capacitor connected between this terminal and ground determines the reset signal delay time.
6	BOOTSTRAP	A C_{boot} capacitor connected between this terminal and the output allows to drive properly the internal D-MOS transistor.
7	OUTPUT	Regulator Output.
8	GROUND	Common Ground Terminal
9	SUPPLY VOLTAGE	Unregulated Input Voltage.
10	FREQUENCY COMPENSATION	A series RC network connected between this terminal and ground determines the regulation loop gain characteristics.
11	FEEDBACK INPUT	The Feedback Terminal of the Regulation Loop. The output is connected directly to this terminal for 5.1V operation; It is connected via a divider for higher voltages.
12	SOFT START	Soft Start Time Constant. A capacitor is connected between this terminal and ground to define the soft start time constant.
13	SYNC INPUT	Multiple L4975A are synchronized by connecting pin 13 inputs together or via an external syncr. pulse.
14	V_{ref}	5.1V V_{ref} Device Reference Voltage.
15	V_{start}	Internal Start-up Circuit to Drive the Power Stage.

CIRCUIT OPERATION (refer to the block diagram)

The L4975A is a 5A monolithic stepdown switching regulator working in continuous mode realized in the new BCD Technology. This technology allows the integration of isolated vertical DMOS power transistors plus mixed CMOS/Bipolar transistors.

The device can deliver 5A at an output voltage adjustable from 5.1V to 40V, and contains diagnostic and control functions that make it particularly suitable for microprocessor based systems.

BLOCK DIAGRAM

The block diagram shows the DMOS power transistor and the PWM control loop. Integrated functions include a reference voltage trimmed to 5.1V \pm 2%, soft start, undervoltage lockout, oscillator with feedforward control, pulse by pulse current limit, thermal shutdown and finally the reset and power fail circuit. The reset and power fail circuit provides an output signal for a microprocessor indicating the status of the system.

Device turn on is around 11V with a typical 1V hysteresis, this threshold provides a correct voltage for the driving stage of the DMOS gate and the hysteresis prevents instabilities.

An external bootstrap capacitor charged to 12V by an internal voltage reference is needed to provide correct gate drive to the power DMOS. The driving circuit is able to source and sink peak currents of around 0.5A to the gate of the DMOS transistor. A typical switching time of the current in the DMOS transistor is 50ns. Due to the fast commutation switching frequencies up to 500kHz are possible.

The PWM control loop consists of a sawtooth oscillator, error amplifier, comparator, latch and the output stage. An error signal is produced by comparing the output voltage with the precise 5.1V \pm 2% on chip reference. This error signal is then compared with the sawtooth oscillator, in order to generate a fixed frequency pulse width modulated drive for the output stage. A PWM latch is included to eliminate multiple pulsing within a period even in noisy environments. The gain and

Figure 1: Feedforward Waveform

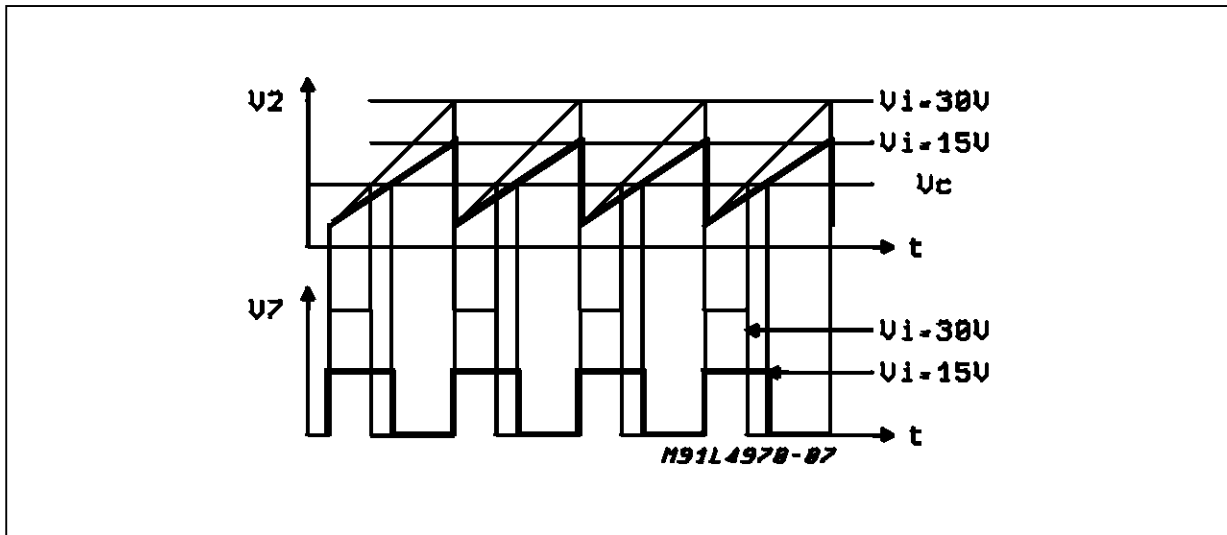

Figure 2: Soft Start Function

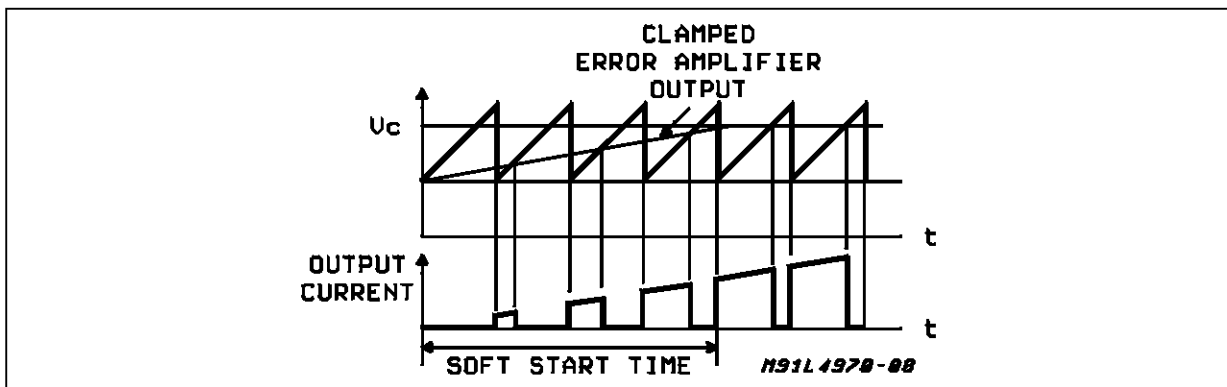
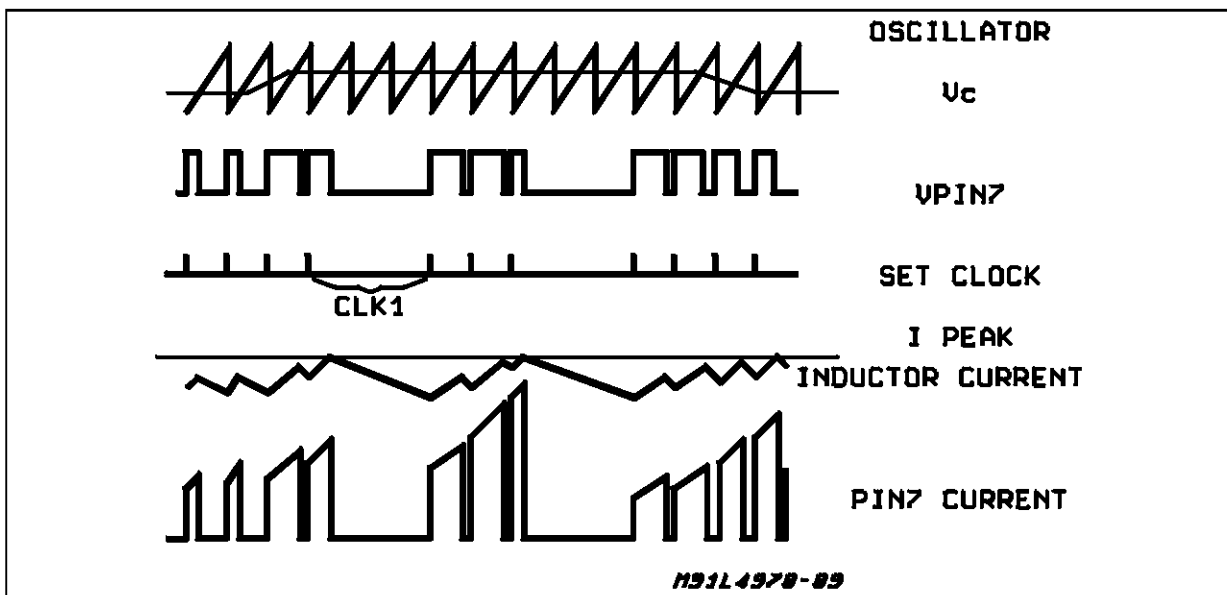

Figure 3: Limiting Current Function



stability of the loop can be adjusted by an external RC network connected to the output of the error amplifier. A voltage feedforward control has been added to the oscillator, this maintains superior line regulation over a wide input voltage range. Closing the loop directly gives an output voltage of 5.1V, higher voltages are obtained by inserting a voltage divider.

At turn on output overcurrents are prevented by the soft start function (fig. 2). The error amplifier is initially clamped by an external capacitor C_{ss} and allowed to rise linearly under the charge of an internal constant current source.

Output overload protection is provided by a current limit circuit (fig. 3). The load current is sensed by an internal metal resistor connected to a comparator. When the load current exceeds a preset threshold the output of the comparator sets a flip flop which turns off the power DMOS. The next clock pulse, from an internal 40kHz oscillator will reset the flip flop and the power DMOS will again conduct. This current protection method, ensures

a constant current output when the system is overloaded or short circuited and limits the switching frequency, in this condition, to 40kHz.

The Reset and Power fail circuitry (fig 4) generates an output signal when the supply voltage exceeds a threshold programmed by an external voltage divider. The reset signal, is generated with a delay time programmed by an external capacitor on the delay pin. When the supply voltage falls below the threshold or the output voltage goes below 5V the reset output goes low immediately. The reset output is an open collector-drain.

Fig 4A shows the case when the supply voltage is higher than the threshold, but the output voltage is not yet 5V.

Fig 4B shows the case when the output is 5.1V but the supply voltage is not yet higher than the fixed threshold.

The thermal protection disables circuit operation when the junction temperature reaches about 150°C and has an hysteresis to prevent unstable conditions.

Figure 4: Reset and Power Fail Functions.

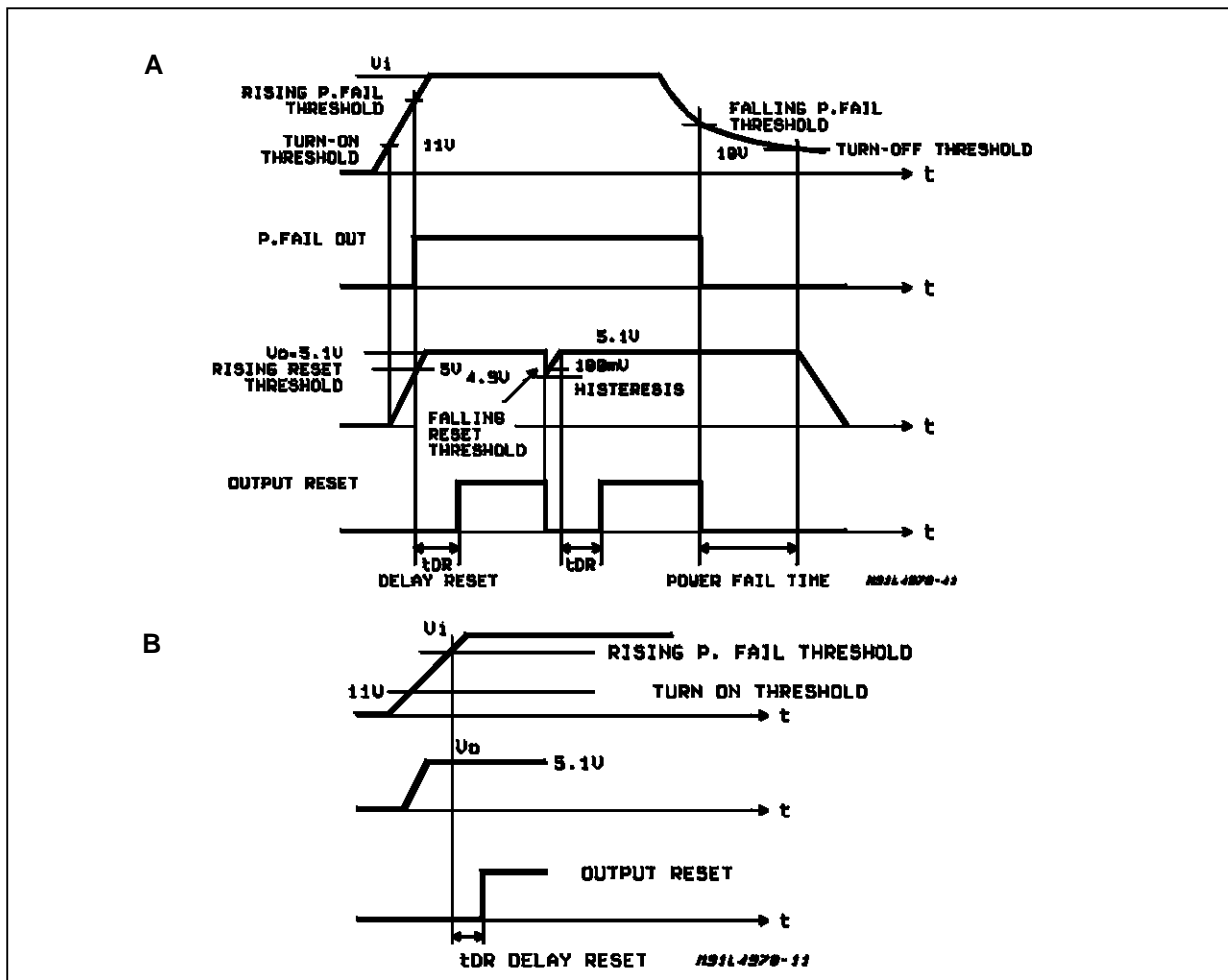

L4975A

ELECTRICAL CHARACTERISTICS (Refer to the test circuit, $T_j = 25^\circ\text{C}$, $V_i = 35\text{V}$, $R_4 = 16\text{K}\Omega$, $C_9 = 2.2\text{nF}$, $f_{\text{SW}} = 200\text{KHz}$ typ, unless otherwise specified)

DYNAMIC CHARACTERISTICS

Symbol	Parameter	Test Condition	Min.	Typ.	Max.	Unit	Fig.
V_i	input Voltage Range (pin 9)	$V_o = V_{\text{ref}}$ to 40V $I_o = 5\text{A}$	15		50	V	5
V_o	Output Voltage	$V_i = 15\text{V}$ to 50V $I_o = 3\text{A}$; $V_o = V_{\text{ref}}$	5	5.1	5.2	V	5
ΔV_o	Line Regulation	$V_i = 15\text{V}$ to 50V $I_o = 2\text{A}$; $V_o = V_{\text{ref}}$		12	30	mV	5
ΔV_o	Load Regulation	$V_o = V_{\text{ref}}$ $I_o = 2\text{A}$ to 4A $I_o = 1\text{A}$ to 5A		10 20	30 50	mV mV	5
V_d	Dropout Voltage Between Pin 9 and 7	$I_o = 3\text{A}$ $I_o = 5\text{A}$		0.4 0.55	0.6 0.8	V V	5
I_{7L}	Max. Limiting Current	$V_i = 15$ to 50V $V_o = V_{\text{ref}}$ to 40V	5.5	6.5	7.5	A	5
η	Efficiency	$I_o = 3\text{A}$ $V_o = V_{\text{ref}}$ $V_o = 12\text{V}$	70	75 80		% %	5
		$I_o = 5\text{A}$ $V_o = V_{\text{ref}}$ $V_o = 12\text{V}$	80	85 92		% %	5
SVR	Supply Voltage Ripple Reject.	$V_i = 2\text{VRMS}$; $I_o = 3\text{A}$ $f = 100\text{Hz}$; $V_o = V_{\text{ref}}$	56	60		dB	5
f	Switching Frequency		180	200	220	KHz	5
$\frac{\Delta f}{\Delta V_i}$	Voltage Stability of Switching Frequency	$V_i = 15\text{V}$ to 45V		2	6	%	5
$\frac{\Delta f}{T_j}$	Temperature Stability of Switching Frequency	$T_j = 0$ to 125°C		1		%	5
f_{max}	Maximum Operating Switching Frequency	$V_o = V_{\text{ref}}$; $R_4 = 10\text{K}\Omega$ $I_o = 5\text{A}$; $C_9 = 1\text{nF}$	500			KHz	5

V_{ref} SECTION (pin 14)

Symbol	Parameter	Test Condition	Min.	Typ.	Max.	Unit	Fig.
V_{14}	Reference Voltage		5	5.1	5.2	V	7
ΔV_{14}	Line Regulation	$V_i = 15\text{V}$ to 50V		10	25	mV	7
ΔV_{14}	Load Regulation	$I_{14} = 0$ to 1mA		20	40	mV	7
$\frac{\Delta V_{14}}{\Delta T}$	Average Temperature Coefficient Reference Voltage	$T_j = 0^\circ\text{C}$ to 125°C		0.4		mV/ $^\circ\text{C}$	7
$I_{14 \text{ short}}$	Short Circuit Current Limit	$V_{14} = 0$		70		mA	7

V_{START} SECTION (pin 15)

Symbol	Parameter	Test Condition	Min.	Typ.	Max.	Unit	Fig.
V_{15}	Reference Voltage		11.4	12	12.6	V	7
ΔV_{15}	Line Regulation	$V_i = 15$ to 50V		0.6	1.4	V	7
ΔV_{15}	Load Regulation	$I_{15} = 0$ to 1mA		50	200	mV	7
$I_{15 \text{ short}}$	Short Circuit Current Limit	$V_{15} = 0\text{V}$		80		mA	7

ELECTRICAL CHARACTERISTICS (continued)**DC CHARACTERISTICS**

Symbol	Parameter	Test Condition	Min.	Typ.	Max.	Unit	Fig.
V_{9on}	Turn-on Threshold		10	11	12	V	7A
V_{9Hyst}	Turn-off Hysteresys			1		V	7A
I_{9Q}	Quiescent Current	$V_{12} = 0$; $S_1 = D$		13	19	mA	7A
I_{9OQ}	Operating Supply Current	$V_{12} = 0$; $S_1 = C$; $S_2 = B$		16	23	mA	7A
I_{7L}	Out Leak Current	$V_i = 55V$; $S_3 = A$; $V_{12} = 0$			2	mA	7A

SOFT START

Symbol	Parameter	Test Condition	Min.	Typ.	Max.	Unit	Fig.
I_{12}	Soft Start Source Current	$V_{12} = 3V$; $V_{11} = 0V$	70	100	130	μA	7B
V_{12}	Output Saturation Voltage	$I_{12} = 20mA$; $V_9 = 10V$			1	V	7B
		$I_{12} = 200\mu A$; $V_9 = 10V$			0.7	V	7B

ERROR AMPLIFIER

Symbol	Parameter	Test Condition	Min.	Typ.	Max.	Unit	Fig.
V_{10H}	High Level Out Voltage	$I_{10} = -100\mu A$; $S_1 = C$ $V_{11} = 4.7V$	6			V	7C
V_{10L}	Low Level Out Voltage	$I_{10} = +100\mu A$; $S_1 = C$ $V_{11} = 5.3V$			1.2	V	7C
I_{10H}	Source Output Current	$V_{10} = 1V$; $S_1 = E$ $V_{11} = 4.7V$	100	150		μA	7C
I_{10L}	Sink Output Current	$V_{10} = 6V$; $S_1 = D$ $V_{11} = 5.3V$	100	150		μA	7C
I_{11}	Input Bias Current	$R_S = 10K\Omega$		0.4	3	μA	–
G_V	DC Open Loop Gain	$V_{VCM} = 4V$; $R_S = 10\Omega$	60			dB	–
SVR	Supply Voltage Rejection	$15 < V_i < 50V$; $R_S = 10\Omega$	60	80		dB	–
V_{OS}	Input Offset Voltage	$R_S = 50\Omega$		2	10	mV	–

RAMP GENERATOR (pin 2)

Symbol	Parameter	Test Condition	Min.	Typ.	Max.	Unit	Fig.
V_2	Ramp Valley	$S_1 = C$; $S_2 = B$	1.2	1.5		V	7A
V_2	Ramp Peak	$S_1 = C$ $V_i = 15V$		2.5		V	7A
		$S_2 = B$ $V_i = 45V$		5.5		V	7A
I_2	Min. Ramp Current	$S_1 = A$; $I_1 = 100\mu A$		270	300	μA	7A
I_2	Max. Ramp Current	$S_1 = A$; $I_1 = 1mA$	2.4	2.7		mA	7A

SYNC FUNCTION (pin 13)

Symbol	Parameter	Test Condition	Min.	Typ.	Max.	Unit	Fig.
V_{13}	Low Input Voltage	$V_i = 15V$ to $50V$; $V_{12} = 0$; $S_1 = C$; $S_2 = B$; $S_4 = B$	-0.3		0.9	V	7A
V_{13}	High Input voltage	$V_{12} = 0$; $S_1 = C$; $S_2 = B$; $S_4 = B$	3.5		5.5	V	7A
I_{13L}	Sync Input Current with Low Input Voltage	$V_2 = V_{13} = 0.9V$; $S_4 = A$; $S_1 = C$; $S_2 = B$			0.4	mA	7A
I_{13H}	Input Current with High Input Voltage	$V_{13} = 3.5V$; $S_4 = A$; $S_1 = C$; $S_2 = B$			1.5	mA	7A
V_{13}	Output Amplitude		4	5		V	–
t_W	Output Pulse Width	$V_{thr} = 2.5V$	0.3	0.5	0.8	μs	–

L4975A

ELECTRICAL CHARACTERISTICS (continued) RESET AND POWER FAIL FUNCTIONS

Symbol	Parameter	Test Condition	Min.	Typ.	Max.	Unit	Fig.
V _{11R}	Rising Threshold Voltage (pin 11)	V _i = 15 to 50V V ₃ = 5.3V	V _{ref} -120	V _{ref} -100	V _{ref} -80	V mV	7D
V _{11F}	Falling Threshold Voltage (pin 11)	V _i = 15 to 50V V ₃ = 5.3V	4.77	V _{ref} -200	V _{ref} -160	V mV	7D
V _{5H}	Delay High Threshold Voltage	V _i = 15 to 50V V ₁₁ = V ₁₄	4.95	5.1	5.25	V	7D
V _{5L}	Delay Low Threshold Voltage	V _i = 15 to 50V V ₁₁ = V ₁₄ V ₃ = 5.3V	1	1.1	1.2	V	7D
-I _{SSO}	Delay Source Current	V ₃ = 5.3V; V ₅ = 3V	40	60	80	μA	7D
I _{SSI}	Delay Sink Current	V ₃ = 4.7V; V ₅ = 3V	10			mA	7D
V _{4S}	Out Saturation Voltage	I ₄ = 15mA; S1 = B V ₃ = 4.7V			0.4	V	7D
I ₄	Output Leak Current	V ₄ = 50V; S1 = A V ₃ = 5.3V			100	μA	7D
V _{3R}	Rising Threshold Voltage	V ₁₁ = V ₁₄	4.95	5.1	5.25	V	7D
V _{3H}	Hysteresis		0.4	0.5	0.6	V	7D
I ₃	Input Bias Current			1	3	μA	7D

Figure 5: Test and Evaluation Board Circuit

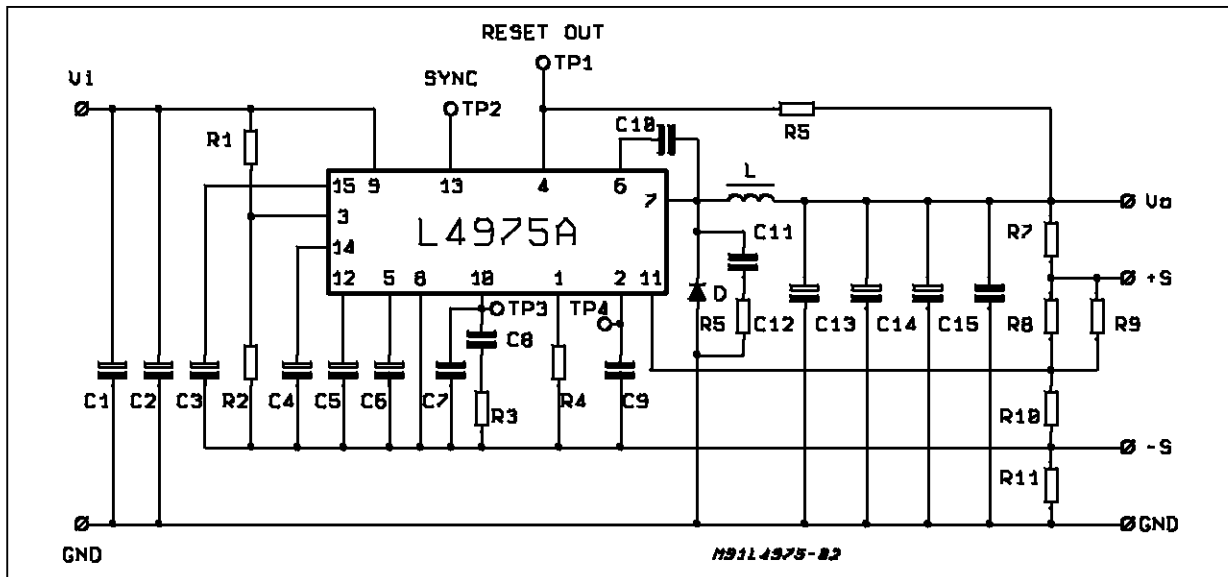

TYPICAL PERFORMANCES (using evaluation board) :

$\eta = 83\%$ (V_i = 35V ; V_o = V_{REF} ; I_o = 5A ; f_{sw} = 200KHz)

V_o RIPPLE = 30mV (at 5A) with output filter capacitor ESR ≤ 60mΩ

Line regulation = 5mV (V_i = 15 to 50V)

Load regulation = 15mV (I_o = 2 to 5A)

For component values, refer to test circuit part list.

Figure 6a: P.C. Board (components side) and Components Layout of Figure 5 (1:1 scale).

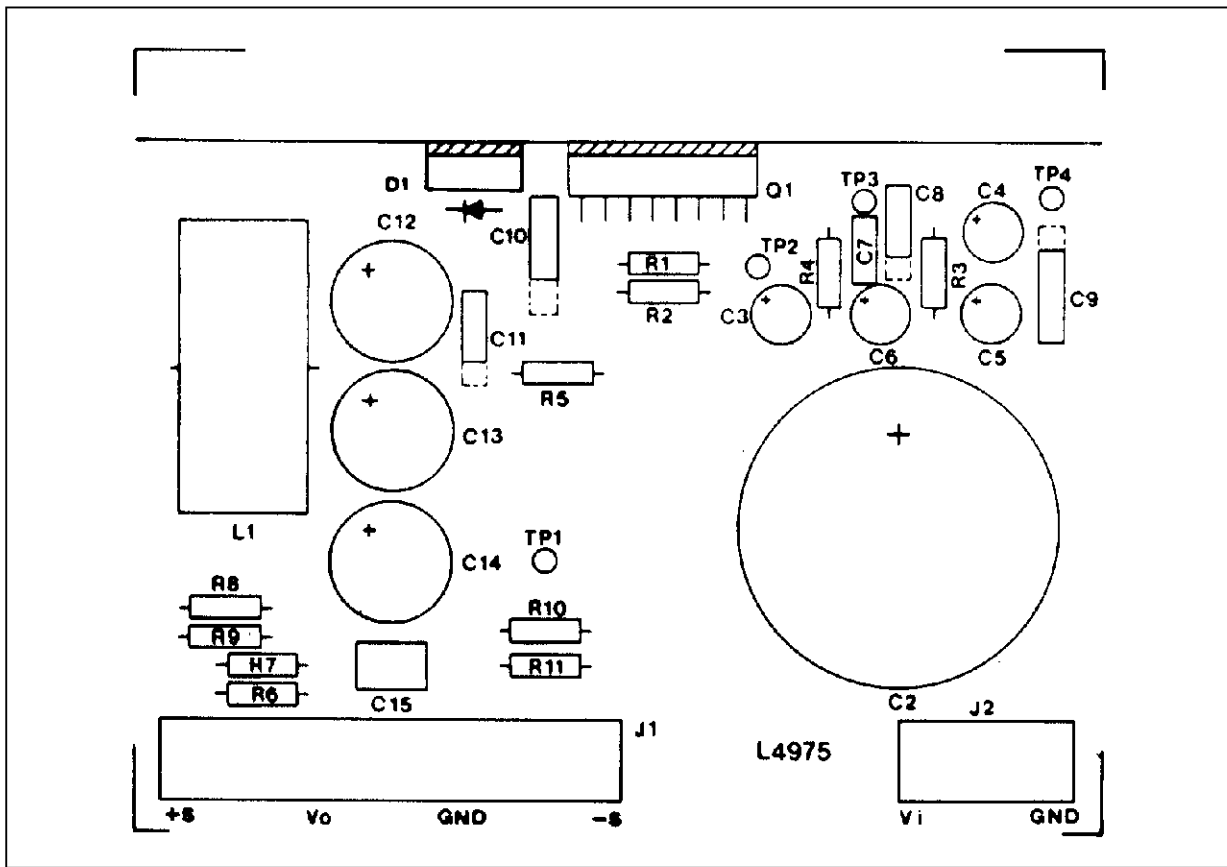

PARTS LIST

R ₁ = 30KΩ	C ₁ , C ₂ = 3300μF 63V _L EYF (ROE)
R ₂ = 10KΩ	C ₃ , C ₄ , C ₅ , C ₆ = 2.2μF
R ₃ = 15KΩ	C ₇ = 390pF Film
R ₄ = 16KΩ	C ₈ = 22nF MKT 1817 (ERO)
R ₅ = 22Ω 0,5W	
R ₆ = 4K7	C ₉ = 2.2nF KP1830
R ₇ = 10Ω	C ₁₀ = 220nF MKT
R ₈ = see tab. A	C ₁₁ = 2.2nF MP1830
R ₉ = OPTION	**C ₁₂ , C ₁₃ , C ₁₄ = 220μF 40V _L EKR
R ₁₀ = 4K7	C ₁₅ = 1μF Film
R ₁₁ = 10Ω	
D1 = MBR 760CT (or 7.5A/60V or equivalent)	
L1 = 80μH	core 58930 MAGNETICS 24 TURNS Ø 1.1mm (AWG 17) COGEMA 949178

* 2 capacitors in parallel to increase input RMS current capability
 ** 3 capacitors in parallel to reduce total output ESR

Table A

V ₀	R ₉	R ₇
12V	4.7kΩ	6.2kΩ
15V	4.7kΩ	9.1kΩ
18V	4.7kΩ	12kΩ
24V	4.7kΩ	18kΩ

Table B
 SUGGESTED BOOTSTRAP CAPACITORS

Operating Frequency	Bootstrap Cap.c10
f = 20KHz	≥680nF
f = 50KHz	≥470nF
f = 100KHz	≥330nF
f = 200KHz	≥220nF
f = 500KHz	≥100nF

Figure 6b: P.C. Board (Back side) and Components Layout of the Circuit of Fig. 5. (1:1 scale)

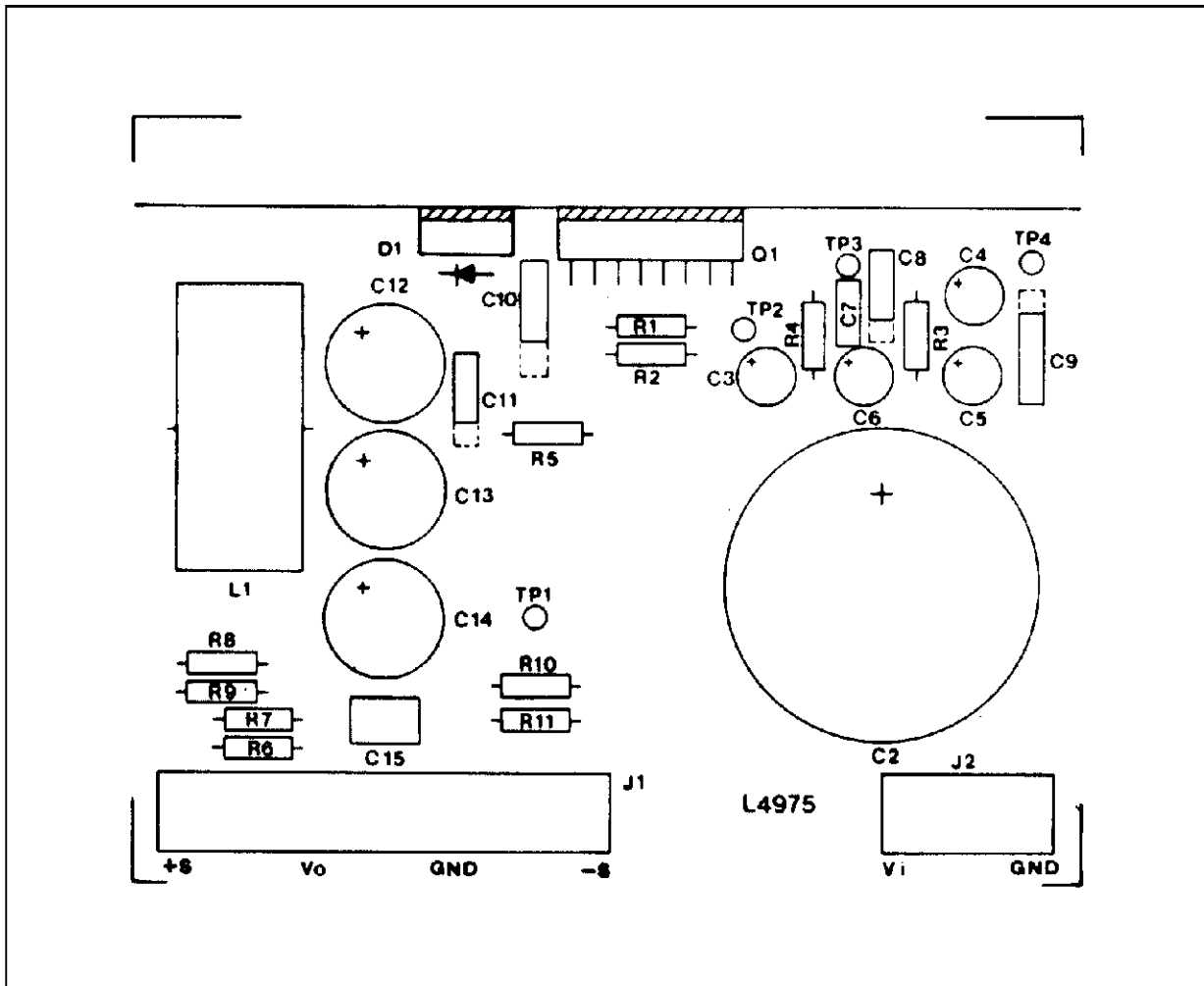

Figure 7: DC Test Circuits

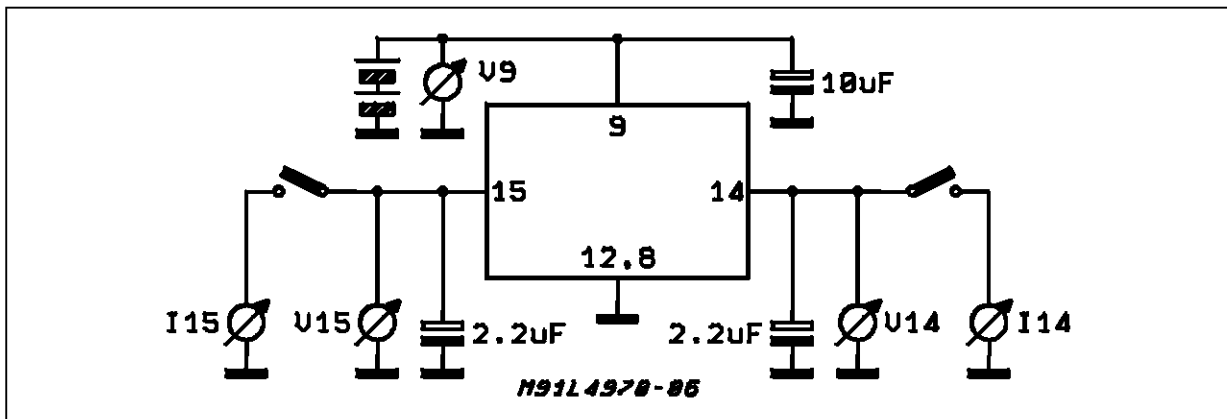

Figure 7A

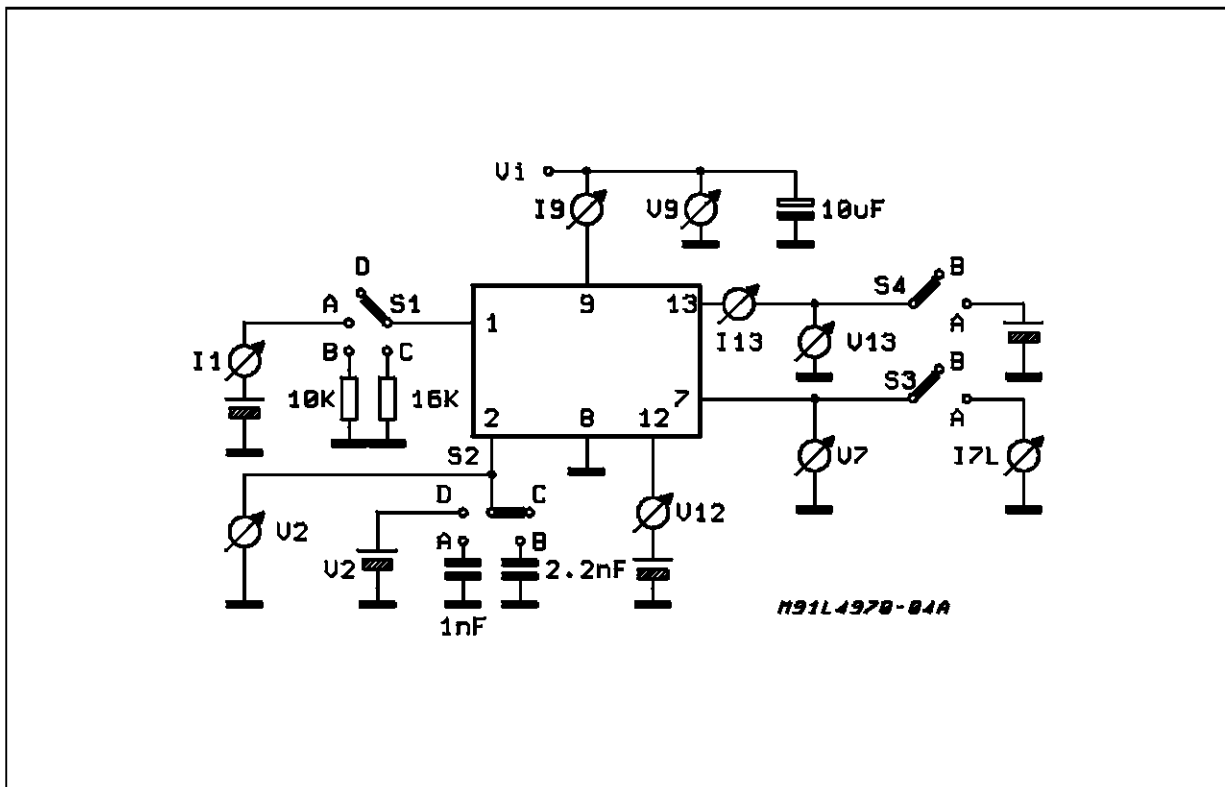

Figure 7B

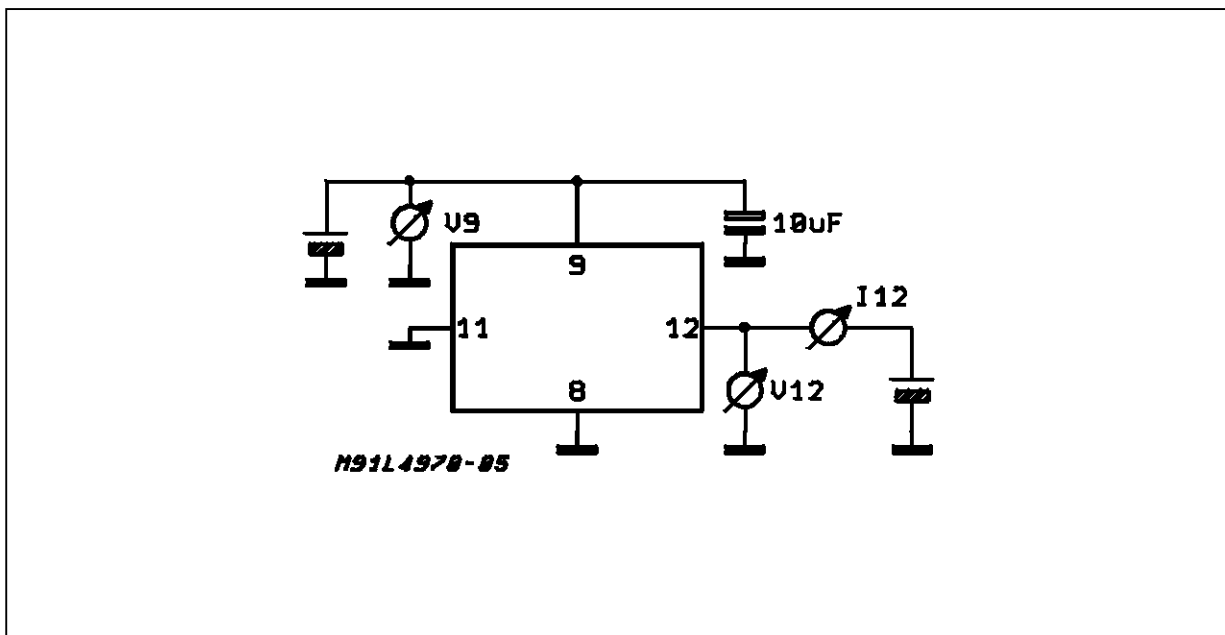

Figure 7D

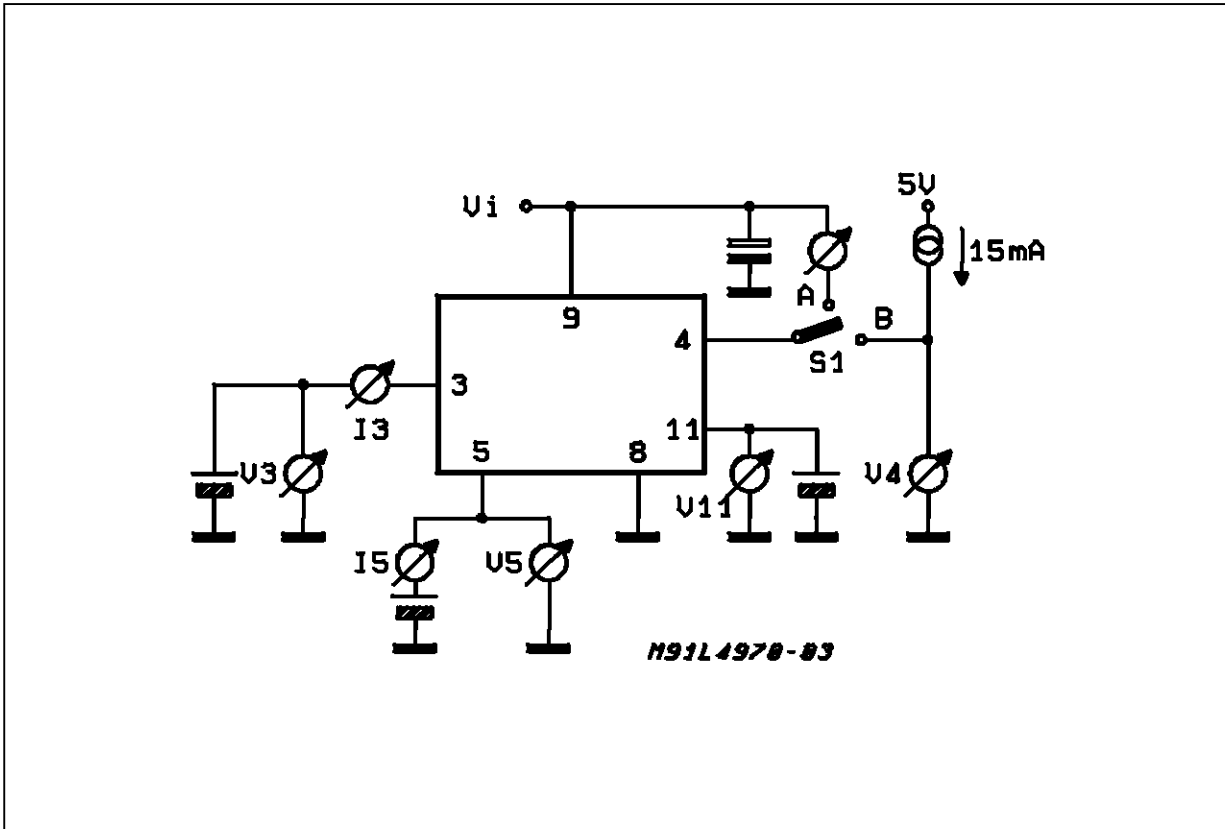

Figure 7C

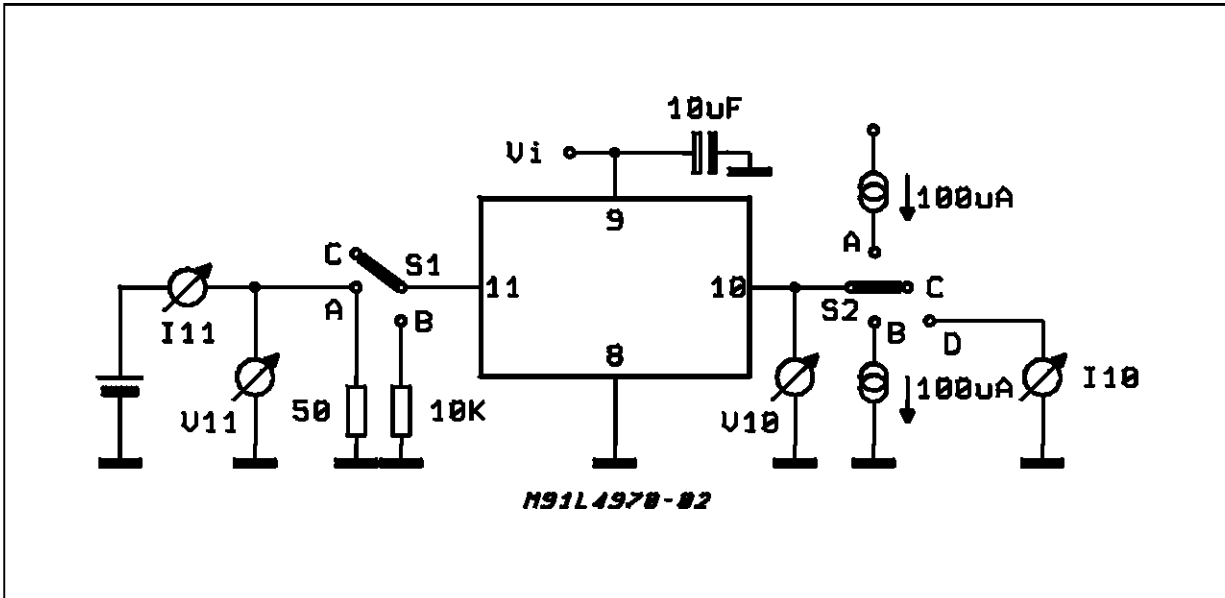

Figure 8: Quiescent Drain Current vs. Supply Voltage (0% duty cycle - see fig. 7A).

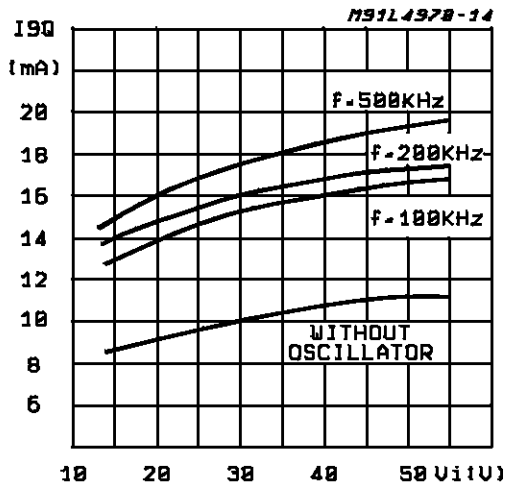

Figure 9: Quiescent Drain Current vs. Junction Temperature (0% duty cycle).

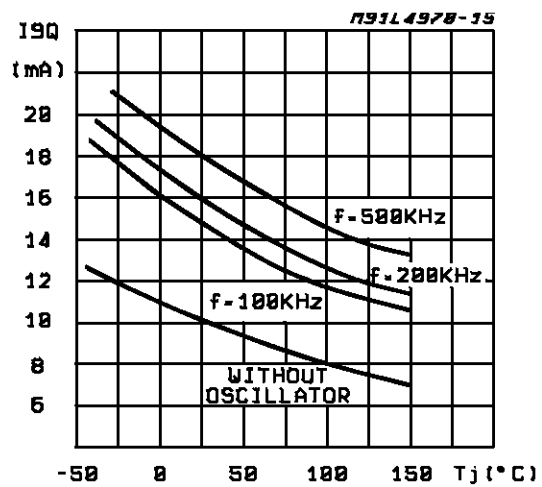

Figure 10: Quiescent Drain Current vs. Duty Cycle

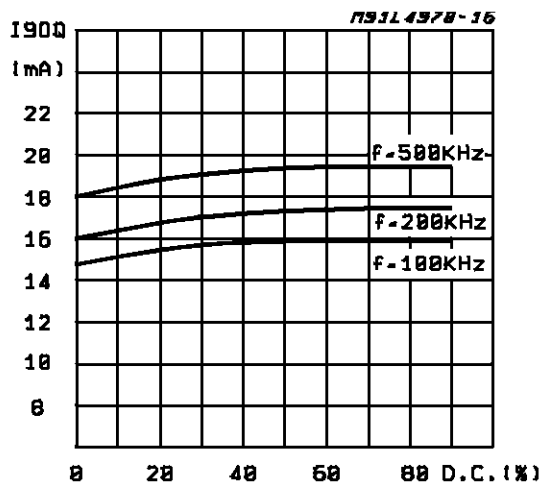

Figure 11: Reference Voltage (pin14) vs. Vi (see fig. 7)

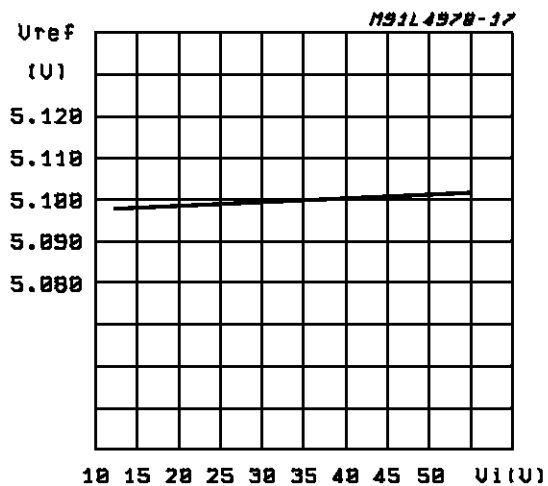

Figure 12: Reference Voltage (pin 14) vs. Junction Temperature (see fig. 7)

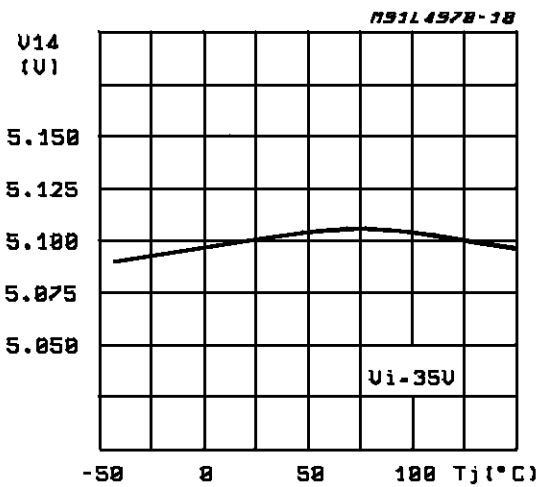

Figure 13: Reference Voltage (pin15) vs. Vi (see fig. 7)

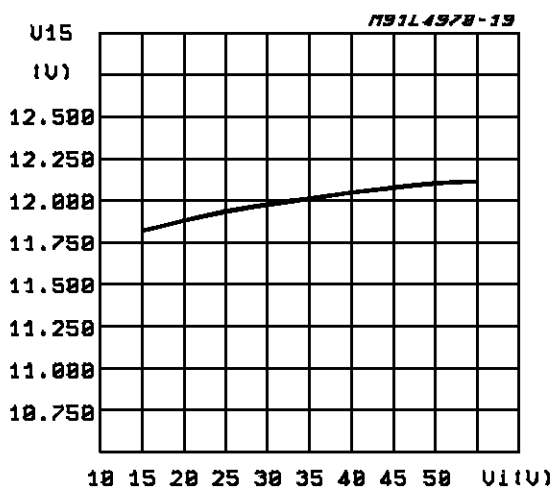

Figure 14: Reference Voltage (pin 15) vs. Junction Temperature (see fig. 7)

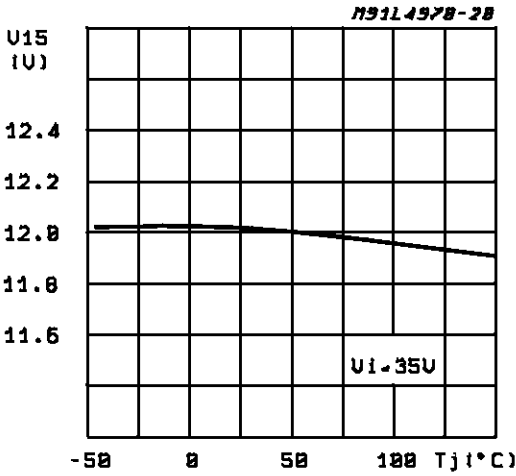

Figure 15: Reference Voltage 5.1V (pin 14) Supply Voltage Ripple Rejection vs. Frequency

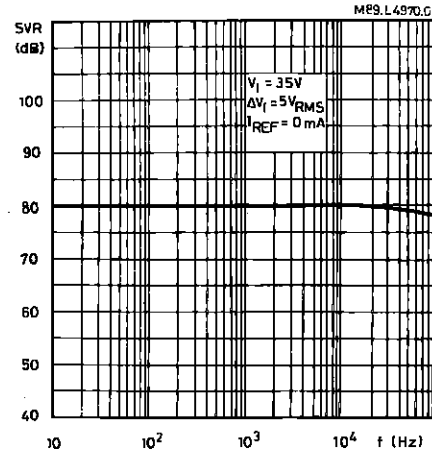

Figure 16: Switching Frequency vs. Input Voltage (see fig. 5)

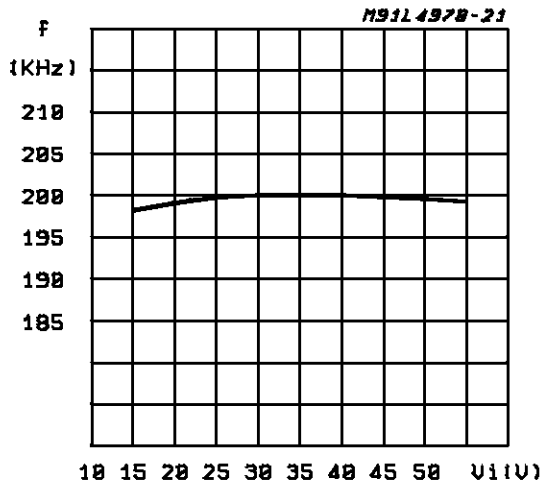

Figure 17: Switching Frequency vs. Junction Temperature (see fig. 5)

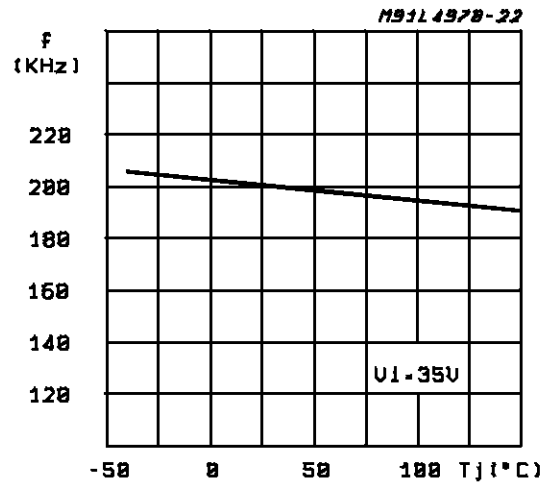

Figure 18: Switching Frequency vs. R4 (see fig. 5)

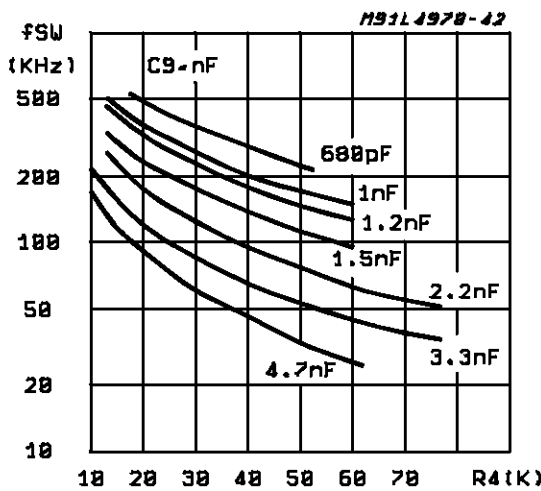

Figure 19: Max. Duty Cycle vs. Frequency

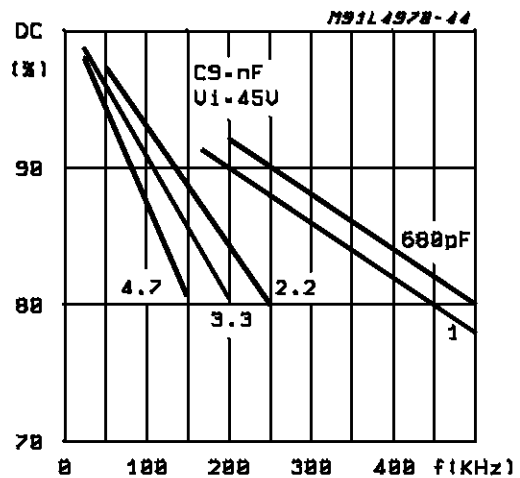

Figure 20: Supply Voltage Ripple Rejection vs. Frequency (see fig. 5)

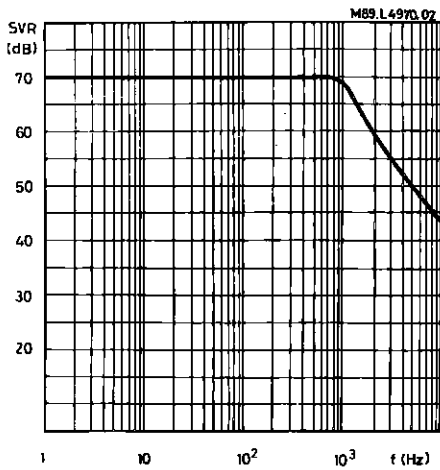

Figure 21: Line Transient Response (see fig. 5)

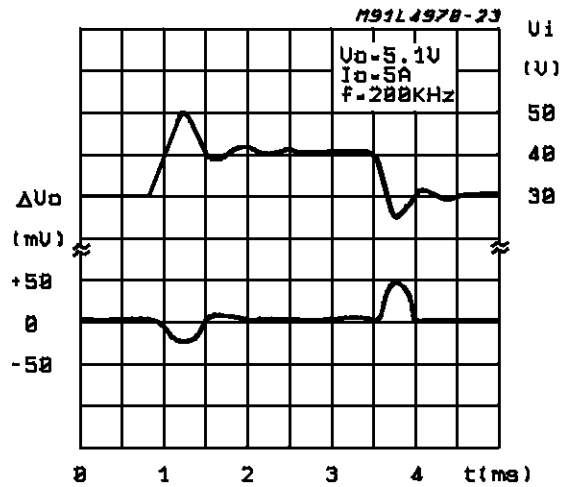

Figure 22: Load Transient Response (see fig. 5)

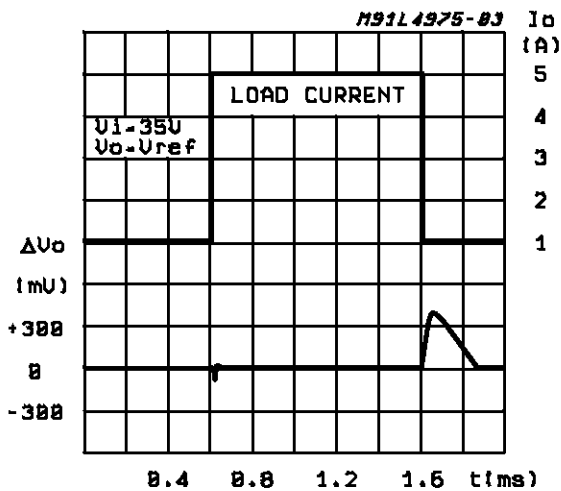

Figure 23: Dropout Voltage Between Pin 9 and Pin 7 vs. Current at Pin 7

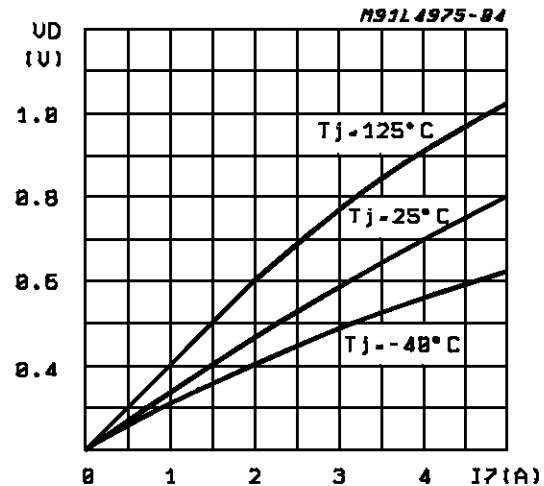

Figure 24: Dropout Voltage Between Pin 9 and Pin 7 vs. Junction Temperature

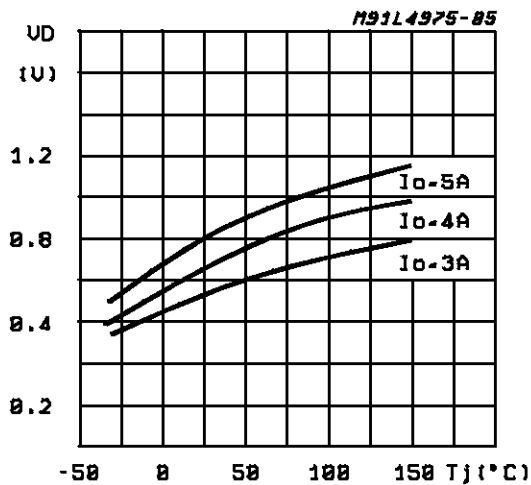

Figure 25: Power Dissipation (device only) vs. Input Voltage

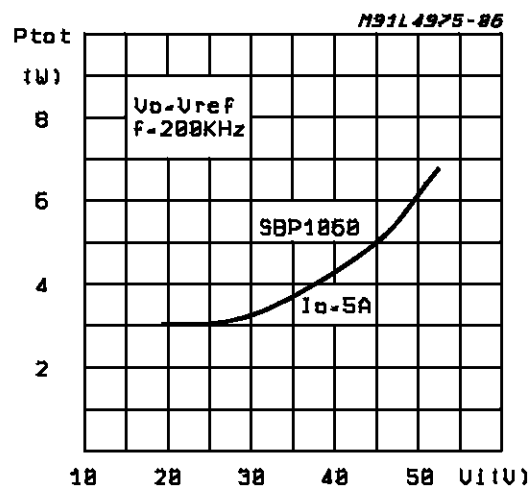

Figure 26: Power Dissipation (device only) vs. Output Voltage

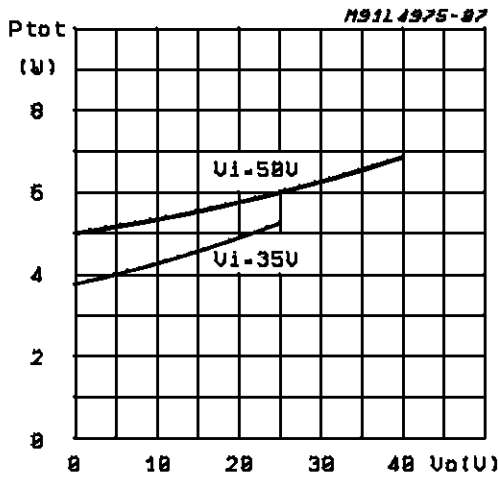

Figure 28: Efficiency vs. Output Current

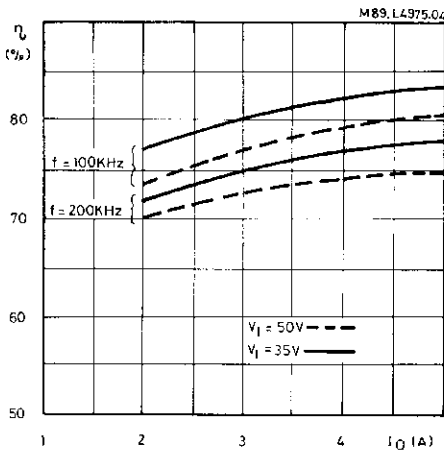

Figure 30: Efficiency vs. Output Voltage

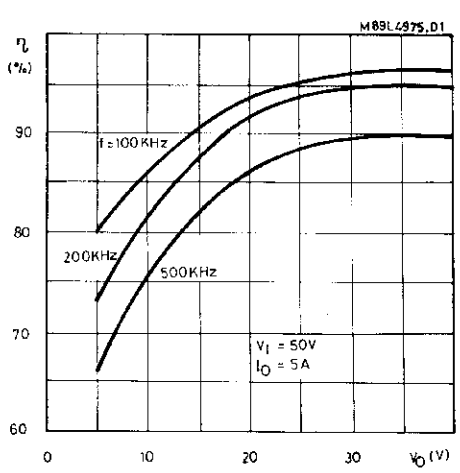

Figure 27: Heatsink Used to Derive the Device's Power Dissipation

$$R_{th} - \text{Heatsink} = \frac{T_{case} - T_{amb}}{P_d}$$

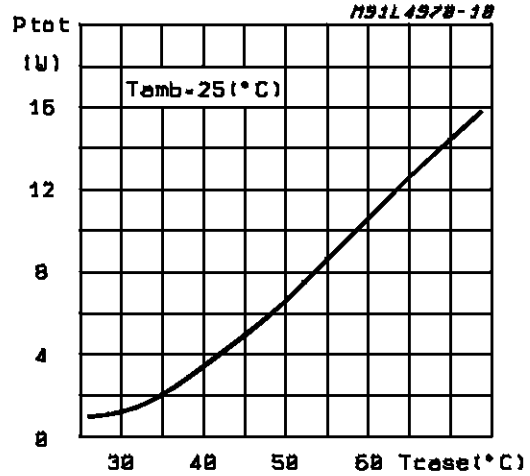

Figure 29: Efficiency vs. Output Voltage

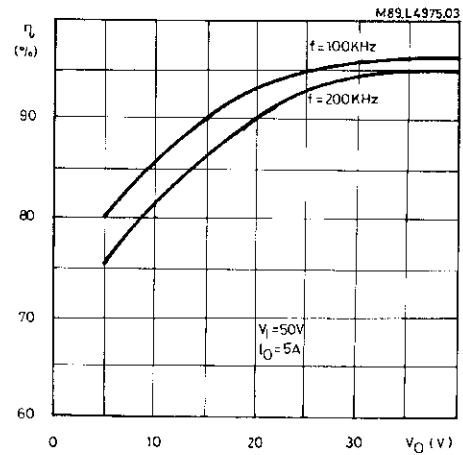

Figure 31: Open Loop Frequency and Phase Response of Error Amplifier (see fig.7C)

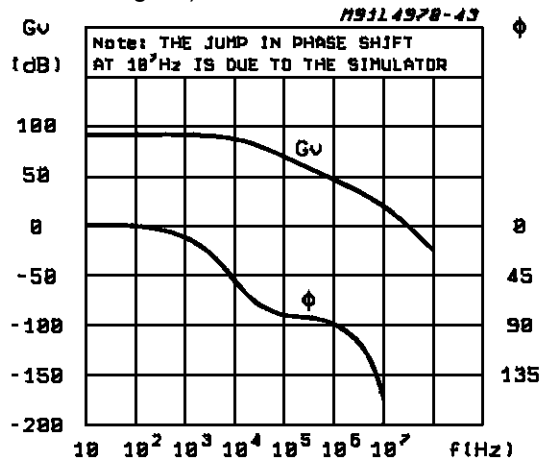

Figure 32: Power Dissipation Derating Curve

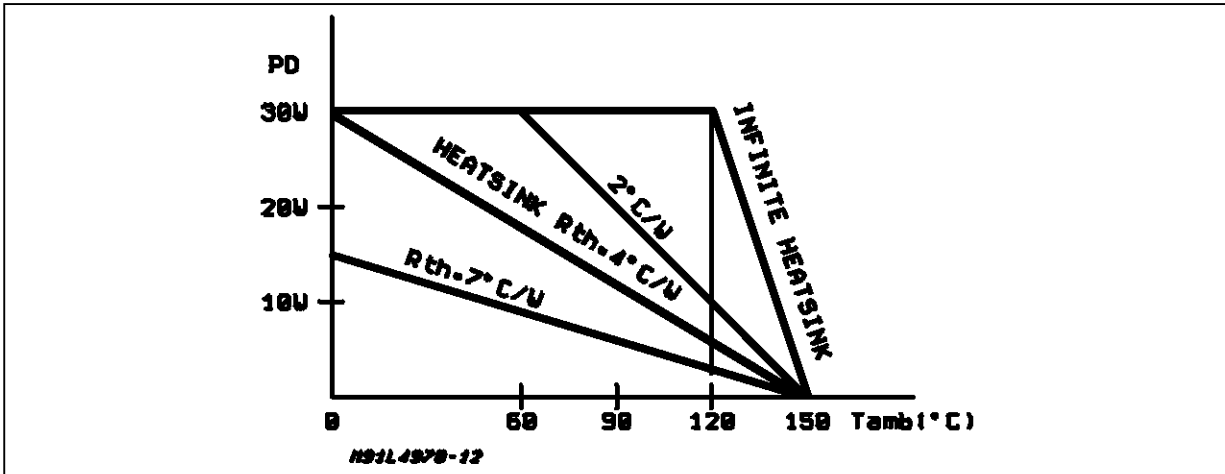
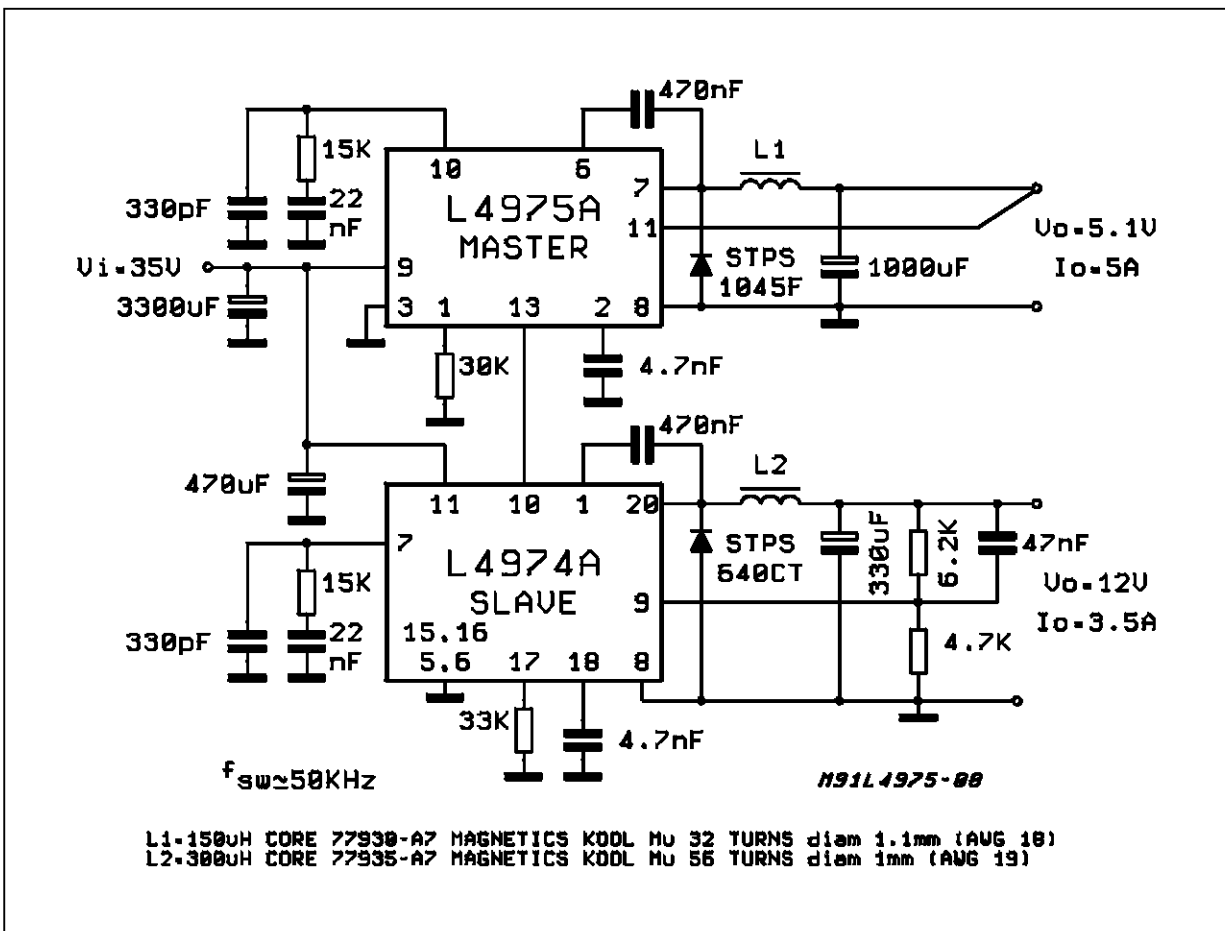

Figure 33: 5.1V/12V Multiple Supply. Note the Synchronization between the L4975A and the L4974A



L4975A

Figure 34: 5.1V / 5A Low Cost Application

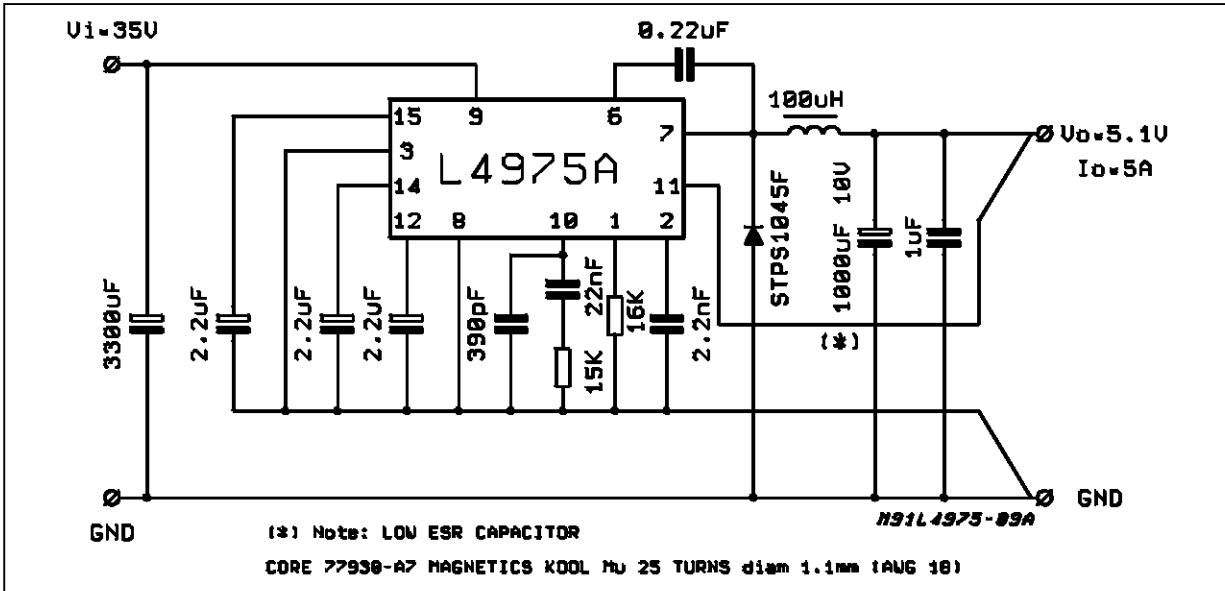

Figure 35: 5A Switching Regulator, Adjustable from 0V to 25V.

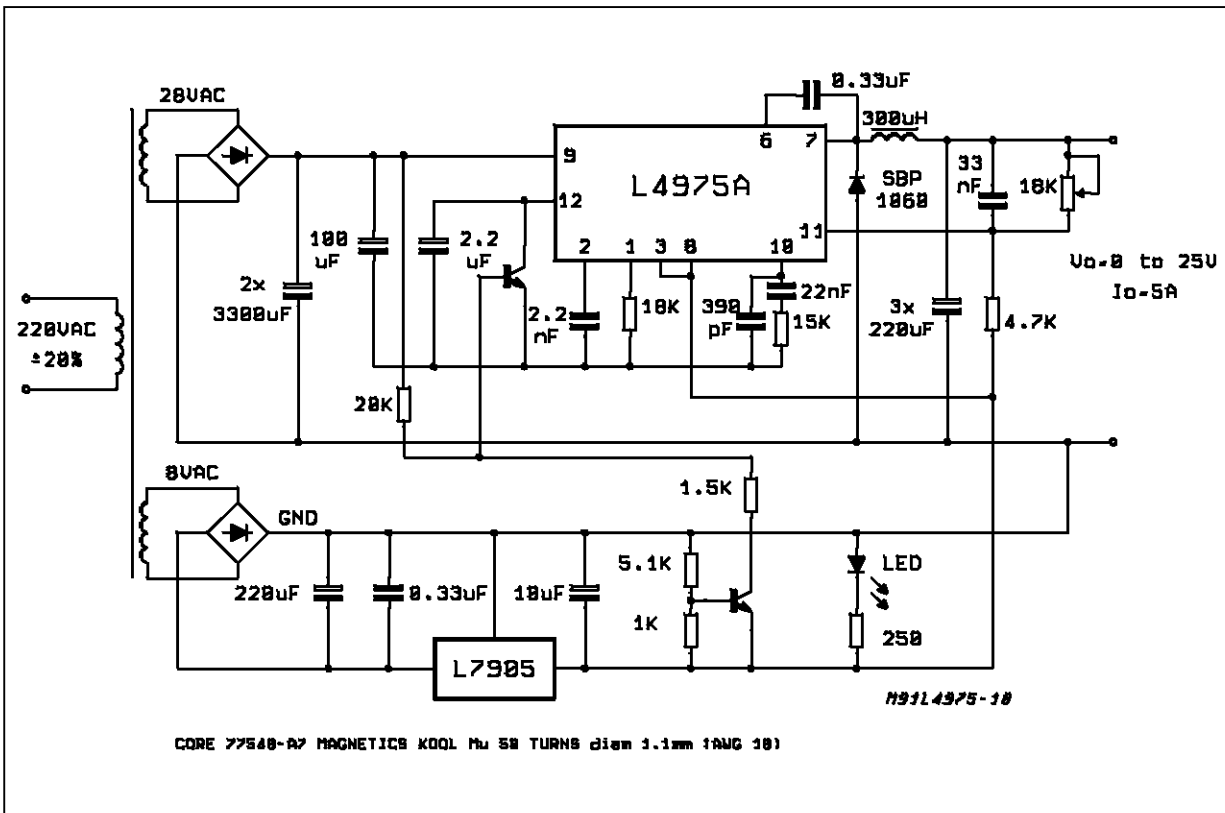
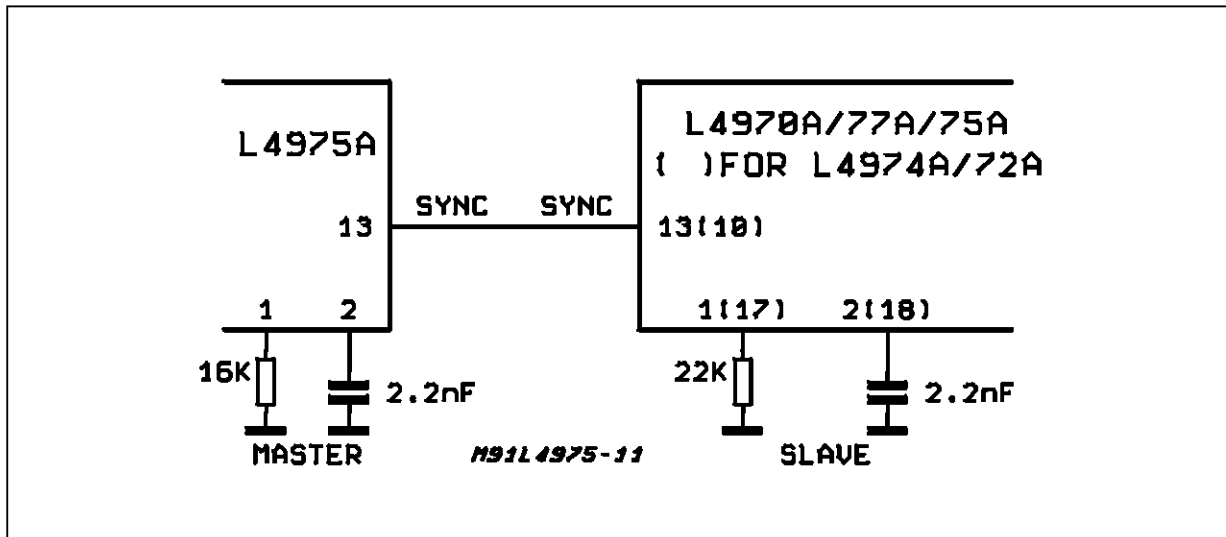
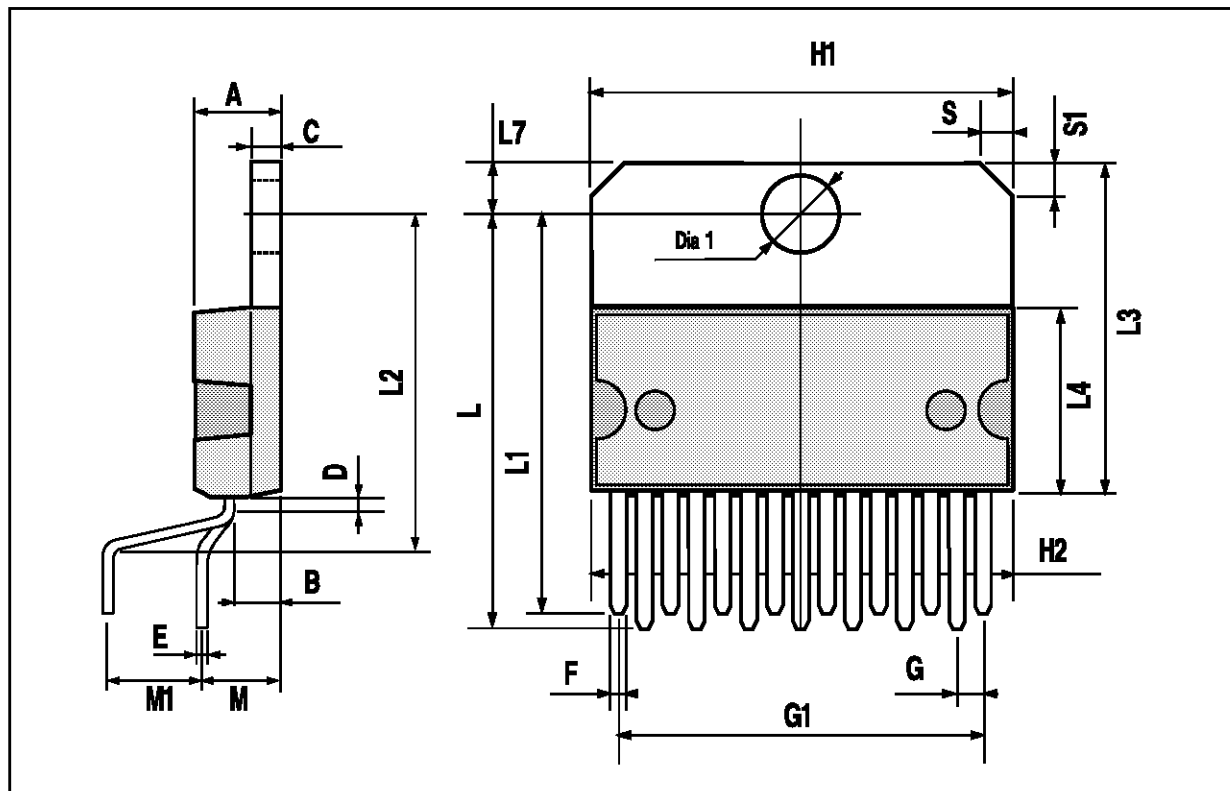

Figure 36: L4975A's Sync. Example



MULTIWATT15 PACKAGE MECHANICAL DATA

DIM.	mm			inch		
	MIN.	TYP.	MAX.	MIN.	TYP.	MAX.
A			5			0.197
B			2.65			0.104
C			1.6			0.063
D		1			0.039	
E	0.49		0.55	0.019		0.022
F	0.66		0.75	0.026		0.030
G	1.14	1.27	1.4	0.045	0.050	0.055
G1	17.57	17.78	17.91	0.692	0.700	0.705
H1	19.6			0.772		
H2			20.2			0.795
L	22.1		22.6	0.870		0.890
L1	22		22.5	0.866		0.886
L2	17.65		18.1	0.695		0.713
L3	17.25	17.5	17.75	0.679	0.689	0.699
L4	10.3	10.7	10.9	0.406	0.421	0.429
L7	2.65		2.9	0.104		0.114
M	4.2	4.3	4.6	0.165	0.169	0.181
M1	4.5	5.08	5.3	0.177	0.200	0.209
S	1.9		2.6	0.075		0.102
S1	1.9		2.6	0.075		0.102
Dia1	3.65		3.85	0.144		0.152



Information furnished is believed to be accurate and reliable. However, SGS-THOMSON Microelectronics assumes no responsibility for the consequences of use of such information nor for any infringement of patents or other rights of third parties which may result from its use. No license is granted by implication or otherwise under any patent or patent rights of SGS-THOMSON Microelectronics. Specifications mentioned in this publication are subject to change without notice. This publication supersedes and replaces all information previously supplied. SGS-THOMSON Microelectronics products are not authorized for use as critical components in life support devices or systems without express written approval of SGS-THOMSON Microelectronics.

© 1994 SGS-THOMSON Microelectronics - All Rights Reserved
MULTIWATT® is a Registered Trademark of SGS-THOMSON Microelectronics

SGS-THOMSON Microelectronics GROUP OF COMPANIES

Australia - Brazil - France - Germany - Hong Kong - Italy - Japan - Korea - Malaysia - Malta - Morocco - The Netherlands - Singapore - Spain - Sweden - Switzerland - Taiwan - Thailand - United Kingdom - U.S.A.