

## LOW POWER QUAD BIPOLAR OPERATIONAL AMPLIFIERS

- SHORT-CIRCUIT PROTECTED OUTPUTS
- CLASS AB OUTPUT STAGE FOR MINIMAL CROSSOVER DISTORTION
- SINGLE SUPPLY OPERATION : + 3 V TO + 36V
- DUAL SUPPLIES :  $\pm 1.5V$  TO  $\pm 18V$
- LOW INPUT BIAS CURRENT : 500nA MAX
- INTERNALLY COMPENSATED
- SIMILAR PERFORMANCE TO POPULAR UA741

### DESCRIPTION

The MC3403 is a low-cost, quad operational amplifier with true differential inputs. The device has electrical characteristics similar to the popular UA741. However the MC3403, has several distinct advantages over standard operational amplifier types in single supply applications. The quad amplifier can operate at supply voltages as low as 3.0 volts or as high as 36 volts with quiescent currents about one third of those associated with the UA741 (on a per amplifier basis). The common-mode input range includes the negative supply, thereby eliminating the necessity for external biasing components in many applications.

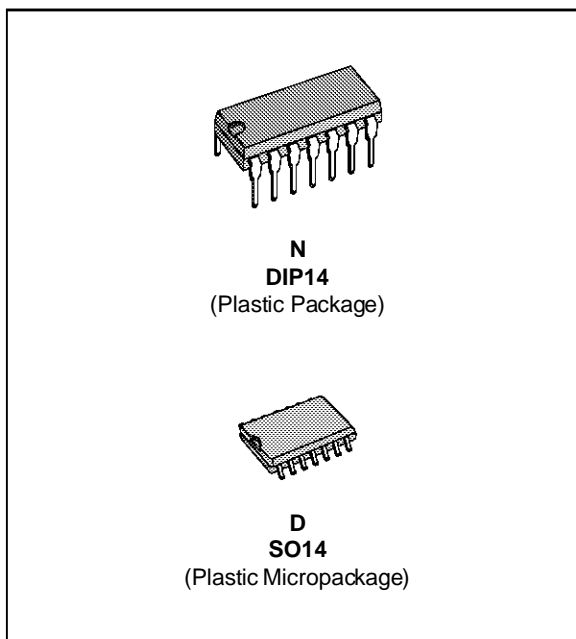

### ORDER CODES

Part Number	Temperature Range	Package	
		N	D
MC3303	-40°C, +105°C	•	•
MC3403	0°C, +70°C	•	•
MC3503	-55°C, +125°C	•	•

**Example** : MC3403N

3303-01.TBL

### PIN CONNECTIONS (top view)

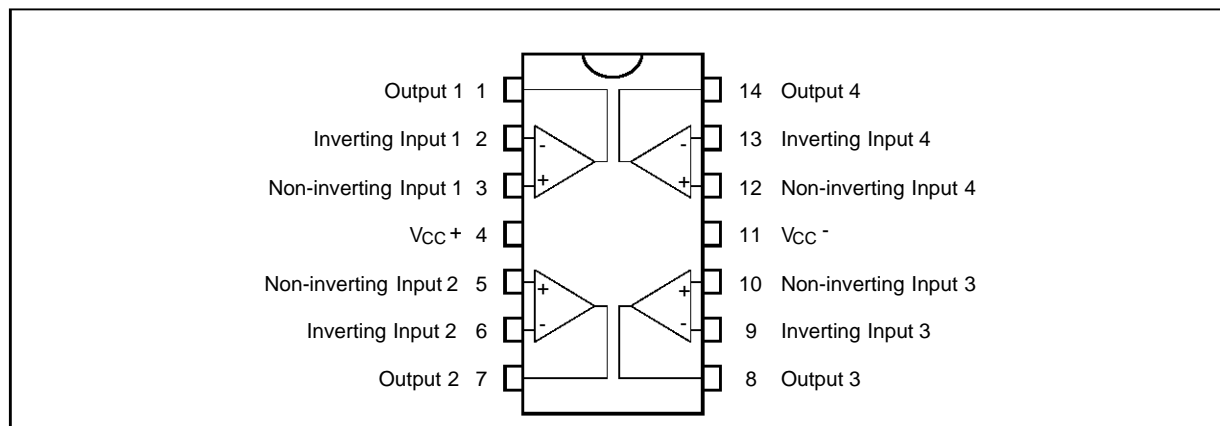

3303-01.EPS

# MC3303 - MC3403 - MC3503

## SCHEMATIC DIAGRAM (each amplifier)

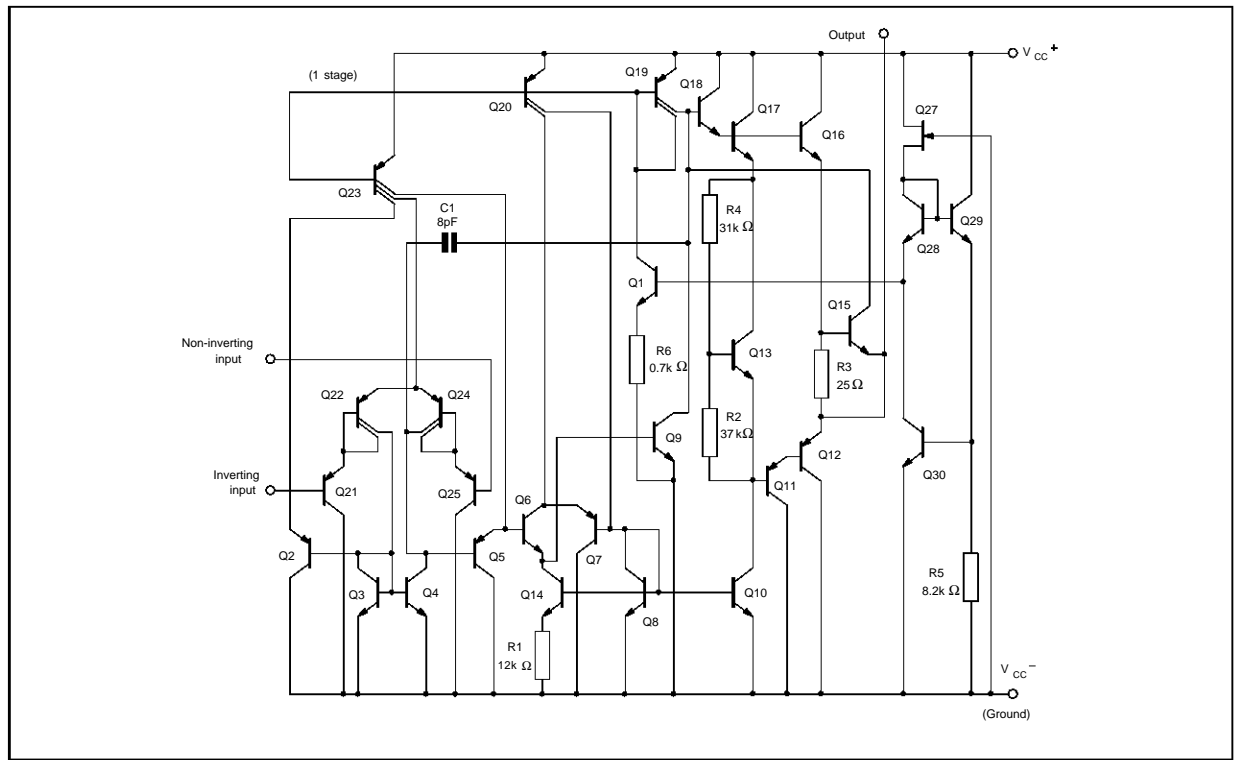

3303-02.EPS

### SINGLE SUPPLY

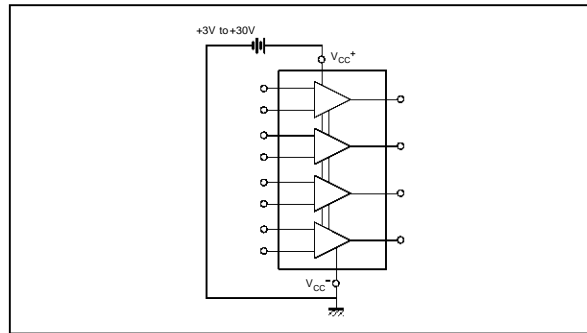

3303-03.EPS

### DUAL SUPPLIES

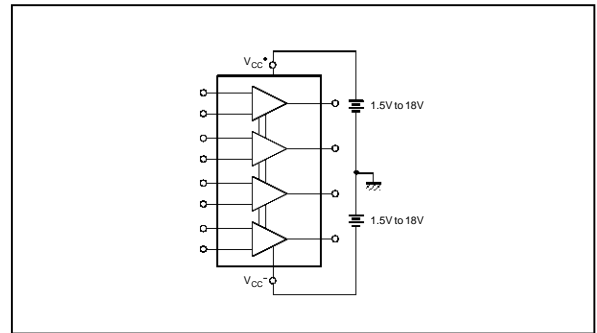

3303-04.EPS

### ABSOLUTE MAXIMUM RATINGS

Symbol	Parameter	MC3503	MC3403	MC3303	Unit
$V_{cc}$	Supply Voltage	$\pm 18$ or 36	$\pm 18$ or 36	$\pm 18$ or 36	V
$V_{id}$	Differential Input Voltage	$\pm 36$	$\pm 36$	$\pm 36$	V
$V_i$	Input Voltage (note 1)	$\pm 18$	$\pm 18$	$\pm 18$	V
—	Output Short-circuit Duration (note 2)	Infinite			—
$P_{tot}$	Power Dissipation	500	500	500	mW
$T_{oper}$	Operating Free-air Temperature Range	$-55$ to $+125$	$0$ to $+70$	$-40$ to $+105$	$^{\circ}C$
$T_{stg}$	Storage Temperature Range	$-65$ to $+150$	$-65$ to $+150$	$-65$ to $+150$	$^{\circ}C$

3303-02.TEL

Notes : 1. For supply voltages less than  $\pm 15V$ , the absolute maximum input voltage is equal to the supply voltage.  
 2. Any of the amplifier outputs can be shorted to ground indefinitely ; however more than one should not be simultaneously shorted as the maximum junction temperature will be exceeded.

**ELECTRICAL CHARACTERISTICS**

$V_{CC} = \pm 15V$ ,  $T_{amb} = +25^{\circ}C$ , (unless otherwise specified)

Symbol	Parameter	MC3303 - MC3403 MC3503			Unit
		Min.	Typ.	Max.	
$V_{IO}$	Input Offset Voltage ( $R_S \leq 10k\Omega$ ) $T_{amb} = 25^{\circ}C$ $T_{min.} \leq T_{amb} \leq T_{max.}$		1	5 6	mV
$I_{IO}$	Input Offset Current $T_{amb} = 25^{\circ}C$ $T_{min.} \leq T_{amb} \leq T_{max.}$		2	50 200	nA
$I_{ib}$	Input Bias Current $T_{amb} = 25^{\circ}C$ $T_{min.} \leq T_{amb} \leq T_{max.}$		40	500 800	nA
$A_{vd}$	Large Signal Voltage Gain ( $V_O = \pm 10V$ , $R_L = 2k\Omega$ ) $T_{amb} = 25^{\circ}C$ $T_{min.} \leq T_{amb} \leq T_{max.}$	50 25	200		V/mV
SVR	Supply Voltage Rejection Ratio ( $R_S \leq 10k\Omega$ ) $T_{amb} = 25^{\circ}C$ $T_{min.} \leq T_{amb} \leq T_{max.}$	77 77	90		dB
$I_{CC}$	Supply Current, all Amp, no Load $T_{amb} = 25^{\circ}C$ $T_{min.} \leq T_{amb} \leq T_{max.}$		2.8	7 4 8 5	mA
$V_{icm}$	Input Common Mode Voltage Range $T_{amb} = 25^{\circ}C$ $T_{min.} \leq T_{amb} \leq T_{max.}$	- 15 - 15		+ 13 + 13	V
CMR	Common Mode Rejection Ratio ( $R_S \leq 10k\Omega$ ) $T_{amb} = 25^{\circ}C$ $T_{min.} \leq T_{amb} \leq T_{max.}$	70 70	90		dB
$I_{OS}$	Output Short-circuit Current	10	30	45	mA
$\pm V_{opp}$	Output Voltage Swing $T_{amb} = 25^{\circ}C$ $T_{min.} \leq T_{amb} \leq T_{max.}$				V
	$R_L = 10k\Omega$	12	13.5		
	$R_L = 2k\Omega$	10	13		
	$R_L = 2k\Omega$	10			
	$R_L = 10k\Omega$	12			
SR	Slew Rate ( $V_I = \pm 10V$ , $R_L = 2k\Omega$ , $C_L = 100pF$ , $T_{amb} = 25^{\circ}C$ , unity gain)	0.35	0.5		V/ $\mu s$
$t_r, t_f$	Rise Time and Fall Time ( $V_O = \pm 20mV$ , $R_L = 2k\Omega$ , $C_L = 100pF$ $T_{amb} = 25^{\circ}C$ , unity gain)		0.18		$\mu s$
$K_{OV}$	Overshoot ( $V_I = \pm 20mV$ , $R_L = 2k\Omega$ , $C_L = 100pF$ , $T_{amb} = 25^{\circ}C$ , unity gain)		10		%
$Z_I$	Input Impedance	0.3	1		M $\Omega$
$Z_O$	Output Impedance		75		$\Omega$
$B_{om}$	Power Bandwidth ( $R_L = 2k\Omega$ , $C_L = 100pF$ , $A_v = 1$ , $T_{amb} = 25^{\circ}C$ , $V_O = 2V_{pp}$ , THD $\leq 5\%$ )		9		kHz
B	Unity Gain Bandwidth ( $V_O = 10mV$ , $R_L = 2k\Omega$ , $C_L = 100pF$ , $T_{amb} = 25^{\circ}C$ , unity gain)		1		MHz
GBP	Gain Bandwidth Product ( $V_O = 10mV$ , $R_L = 2k\Omega$ , $C_L = 100pF$ , $f = 100kHz$ , $T_{amb} = 25^{\circ}C$ )	0.7	1		MHz
THD	Total Harmonic Distortion ( $f = 1kHz$ , $A_v = 20dB$ , $R_L = 2k\Omega$ , $V_O = 2V_{pp}$ , $C_L = 100pF$ , $T_{amb} = 25^{\circ}C$ )		0.02		%
$e_n$	Equivalent Input Noise Voltage ( $f = 1kHz$ , $R_S = 100\Omega$ )		43		$\frac{nV}{\sqrt{Hz}}$

3303-03.TEL

## MC3303 - MC3403 - MC3503

### ELECTRICAL CHARACTERISTICS (continued)

Symbol	Parameter	MC3303 - MC3403 - MC3503			Unit
		Min.	Typ.	Max.	
$\phi_m$	Phase Margin		60		Degrees
DV <sub>IO</sub>	Input Offset Voltage Drift $T_{min.} \leq T_{amb} \leq T_{max.}$		10		$\mu V/^{\circ}C$
DI <sub>IO</sub>	Input Offset Current Drift $T_{min.} \leq T_{amb} \leq 25^{\circ}C$		50		$pA/^{\circ}C$
V <sub>O1</sub> /V <sub>O2</sub>	Channel Separation		120		dB

3303-04.TBL

### ELECTRICAL CHARACTERISTICS

V<sub>CC+</sub> = 5V, V<sub>CC-</sub> = Ground, T<sub>amb</sub> = 25°C (unless otherwise specified)

Symbol	Parameter	MC3303 - MC3403 - MC3503			Unit
		Min.	Typ.	Max.	
V <sub>IO</sub>	Input Offset Voltage (R <sub>S</sub> ≤ 10kΩ) T <sub>amb</sub> = 25°C T <sub>min.</sub> ≤ T <sub>amb</sub> ≤ T <sub>max.</sub>		1	5 6	mV
I <sub>IO</sub>	Input Offset Current T <sub>amb</sub> = 25°C T <sub>min.</sub> ≤ T <sub>amb</sub> ≤ T <sub>max.</sub>		2	50 200	nA
I <sub>ib</sub>	Input Bias Current T <sub>amb</sub> = 25°C T <sub>min.</sub> ≤ T <sub>amb</sub> ≤ T <sub>max.</sub>		40	500 800	nA
A <sub>vd</sub>	Large Signal Voltage Gain (V <sub>O</sub> = 1.4 to 2.4V, R <sub>L</sub> = 2kΩ) T <sub>amb</sub> = 25°C T <sub>min.</sub> ≤ T <sub>amb</sub> ≤ T <sub>max.</sub>	10 5	200		V/mV
SVR	Supply Voltage Rejection Ratio (R <sub>S</sub> ≤ 10kΩ) T <sub>amb</sub> = 25°C T <sub>min.</sub> ≤ T <sub>amb</sub> ≤ T <sub>max.</sub>	77 77	90		dB
I <sub>CC</sub>	Supply Current (All Amp) MC3503		2.5	7 4	mA
V <sub>opp</sub>	Output Voltage Range (R <sub>L</sub> = 10kΩ) V <sub>CC</sub> = +5V +5 < V <sub>CC</sub> ≤ +30V	3.3 V <sub>CC+</sub> -2V	3.5 V <sub>CC+</sub> -1.7V		V

3303-05.TBL

**CIRCUIT DESCRIPTION**

The MC3403 is made using four internally compensated, two-stage operational amplifiers. The first stage of each consists of differential input devices Q24 and Q22 with input buffer transistors Q25 and Q21 and the differential to single ended converter Q3 and Q4. The first stage performs not only the first stage gain function but also performs the level shifting and transconductance reduction functions. By reducing the transconductance a smaller compensation capacitor (only 8pF) can be employed, thus saving chip area.

The transconductance reduction is accomplished by splitting the collectors of Q24 and Q22. Another feature of this input stage is that the input common-mode range can include the negative supply of

ground, in single supply operation, without saturation either the input devices or the differential to single-ended converter.

The second stage consists of a standard current source load amplifier stage. The output stage is unique because it allows the output to swing to ground in single supply operation and yet does not exhibit any crossover distortion in split supply operations. This is possible because class AB operation is utilized.

Each amplifier is biased from an internal voltage regulator which has a low temperature coefficient thus giving each amplifier good temperature characteristics as well as excellent power supply rejection.

**TYPICAL PERFORMANCE CURVES**

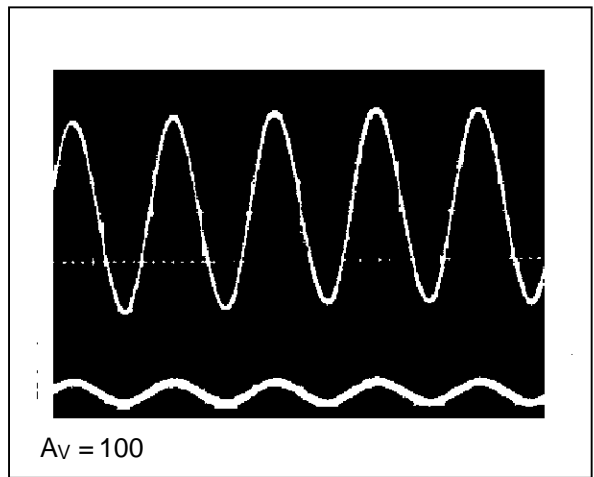
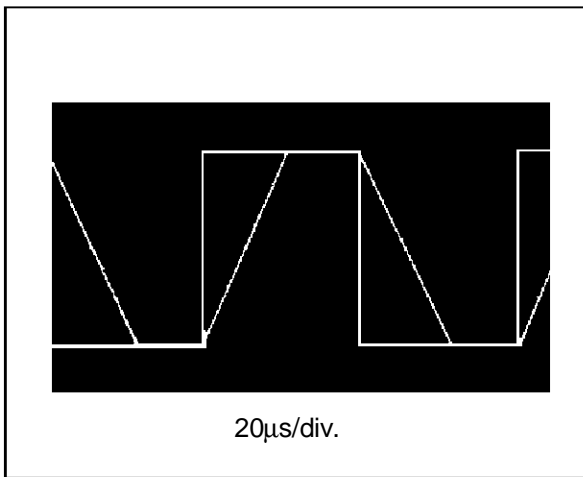

**APPLICATION INFORMATION**

**VOLTAGE REFERENCE**

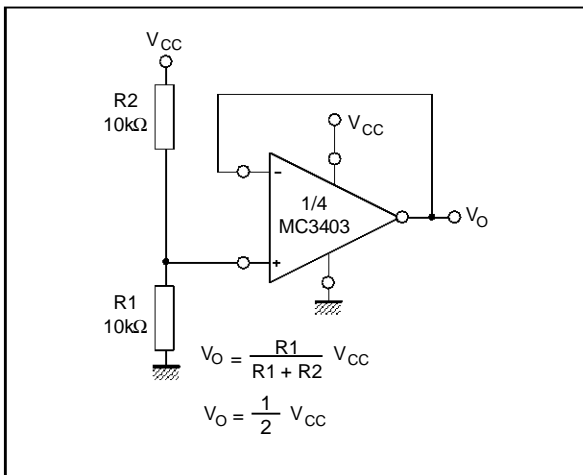

**WIEN BRIDGE OSCILLATOR**

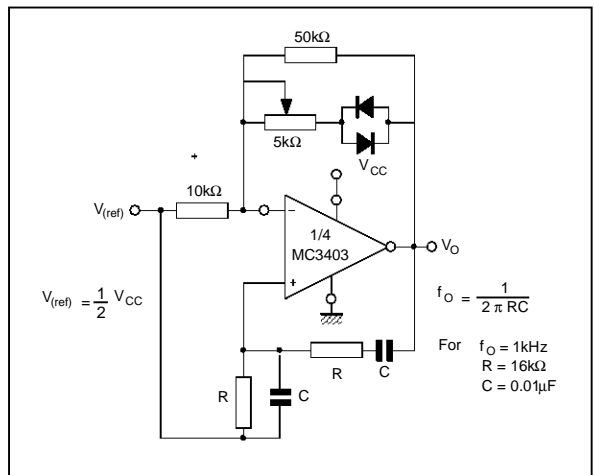

APPLICATION INFORMATION (continued)

HIGH IMPEDANCE DIFFERENTIAL AMPLIFIER

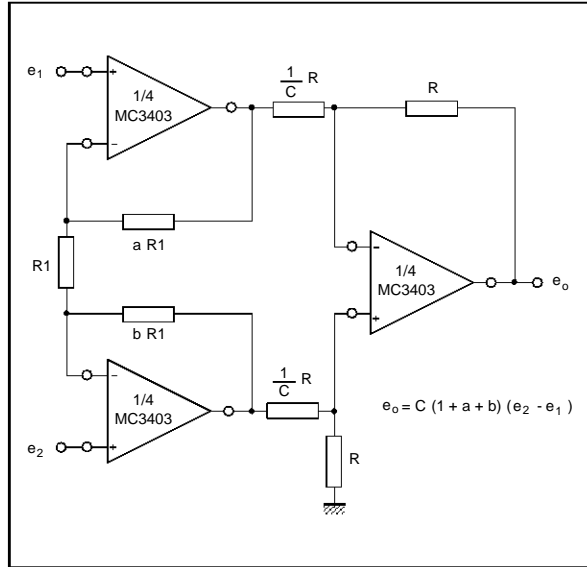

COMPARATOR WITH HYSTERESIS

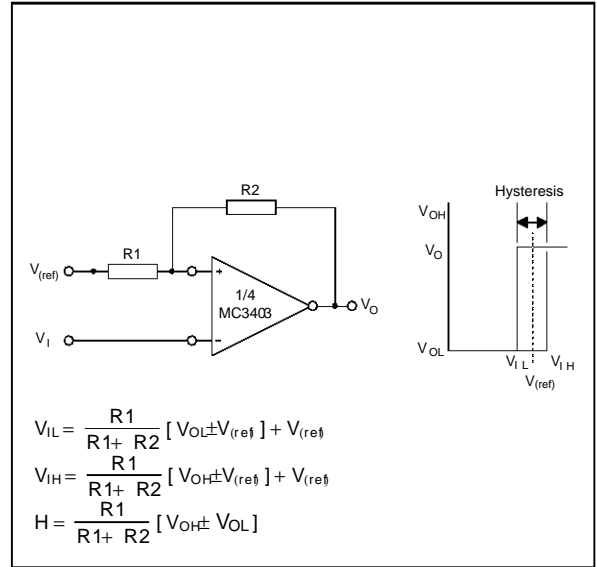

BI-QUAD FILTER

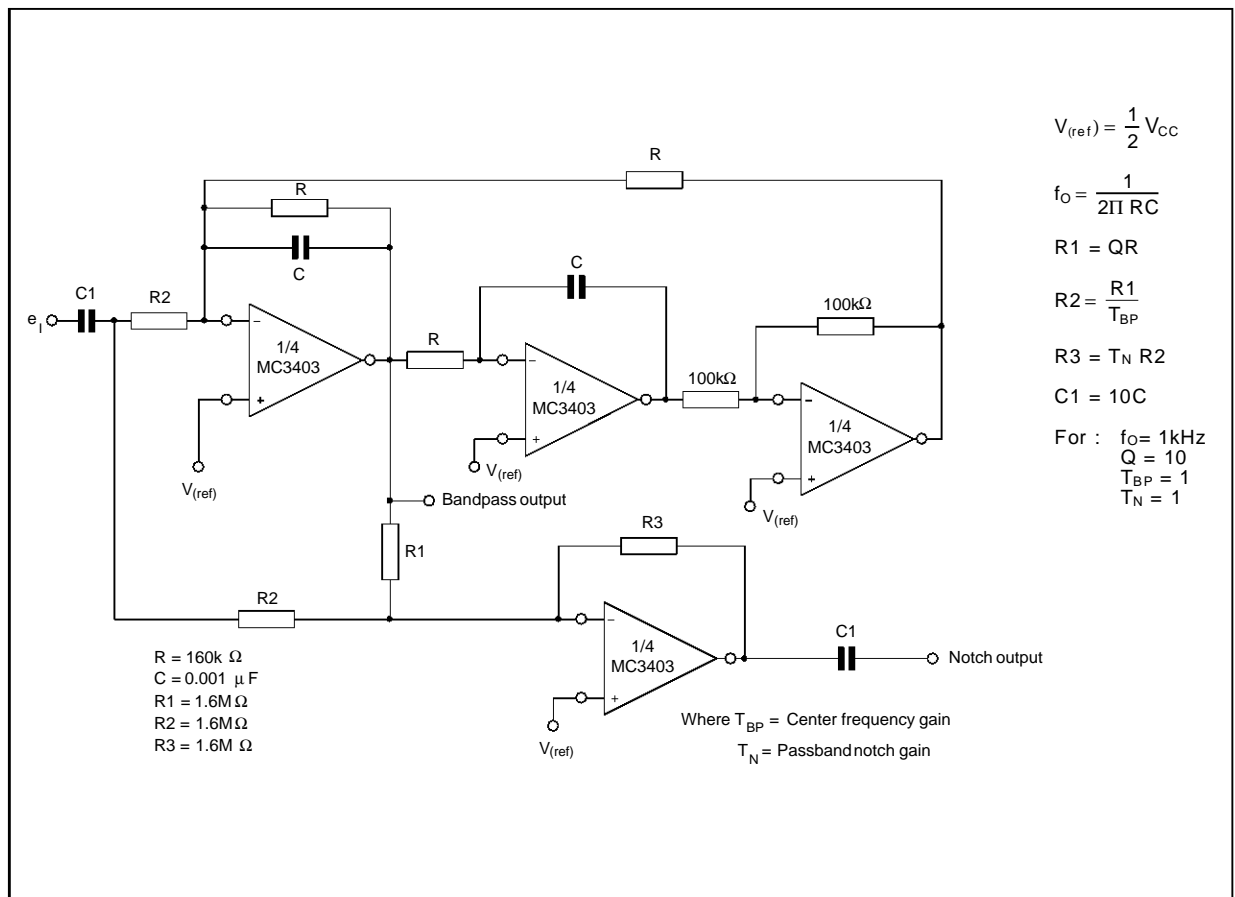

APPLICATION INFORMATION (continued)

FUNCTION GENERATOR

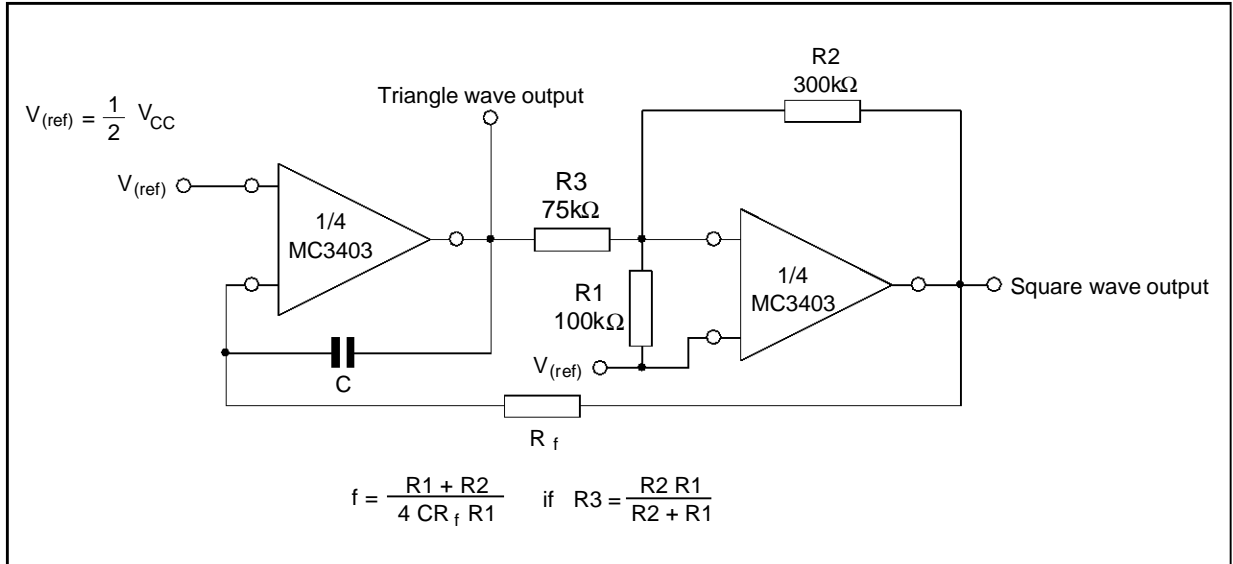

MULTIPLE FEEDBACK BANDPASS FILTER

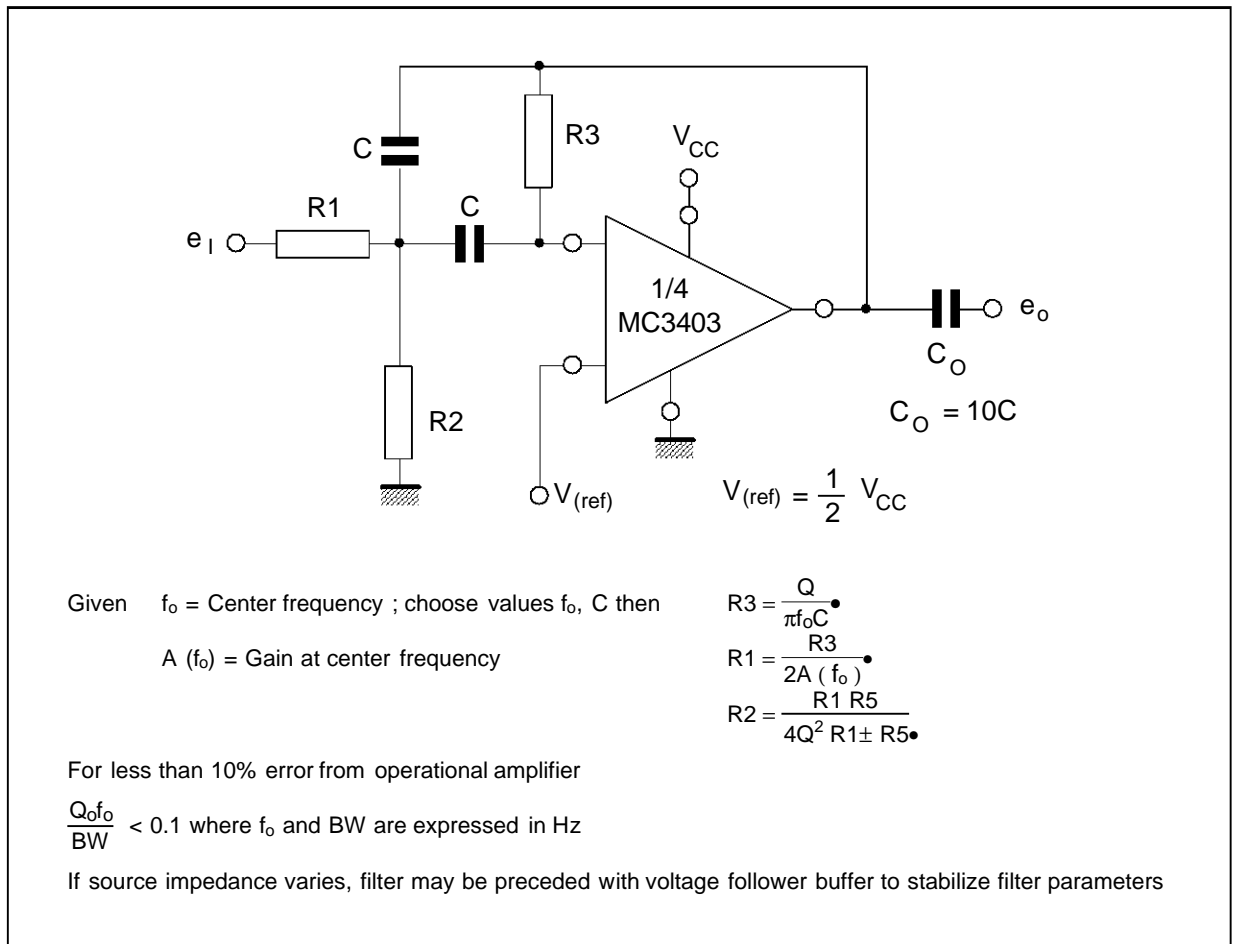

TYPICAL PERFORMANCE CURVES

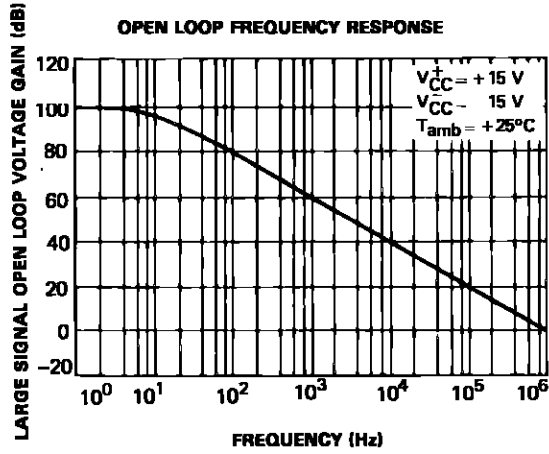

3303-14.EPS

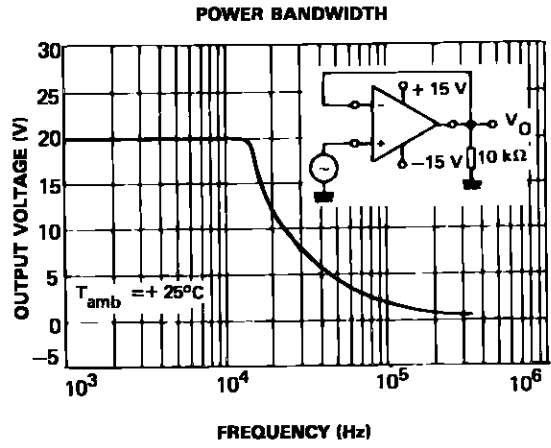

3303-15.EPS

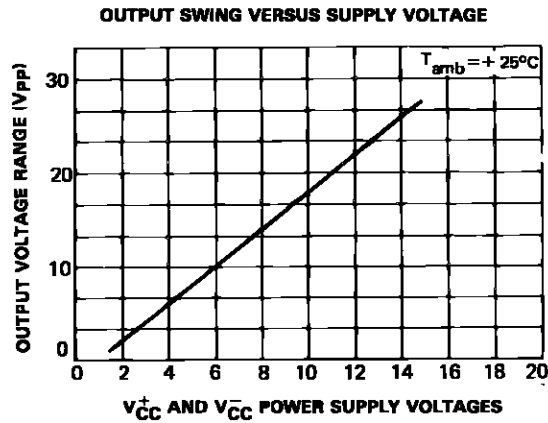

3303-16.EPS

**PACKAGE MECHANICAL DATA**  
 14 PINS - PLASTIC DIP OR CerdIP

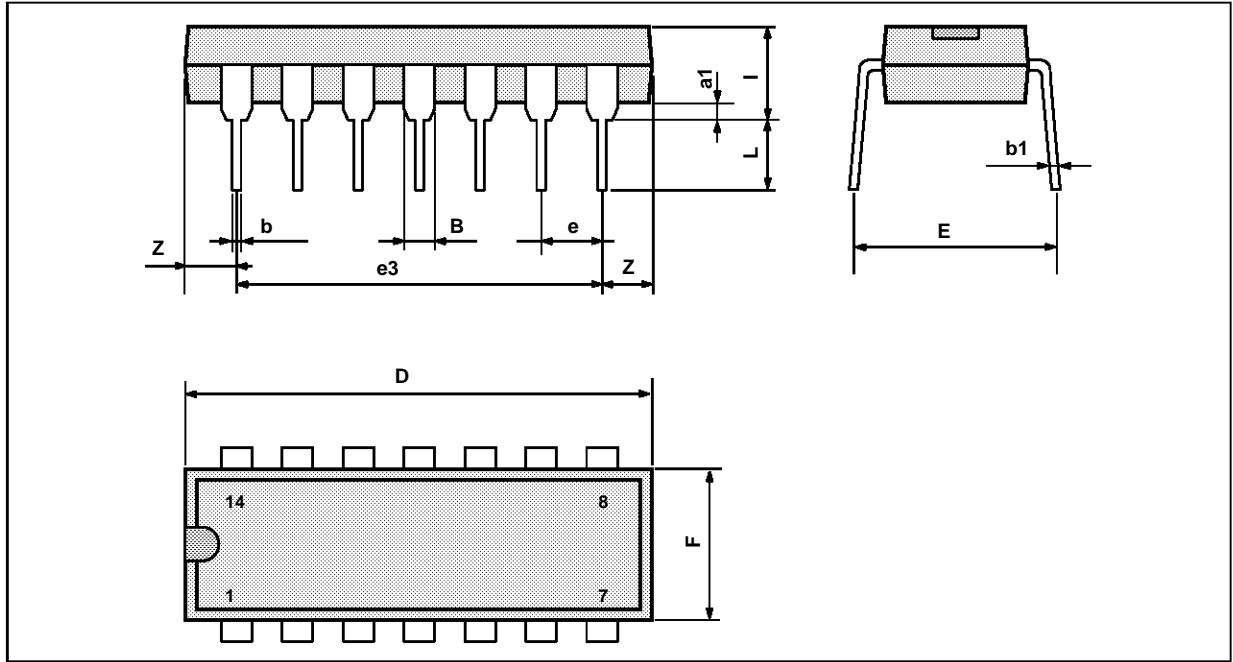

PM-DIP14.EPS

Dimensions	Millimeters			Inches		
	Min.	Typ.	Max.	Min.	Typ.	Max.
a1	0.51			0.020		
B	1.39		1.65	0.055		0.065
b		0.5			0.020	
b1		0.25			0.010	
D			20			0.787
E		8.5			0.335	
e		2.54			0.100	
e3		15.24			0.600	
F			7.1			0.280
i			5.1			0.201
L		3.3			0.130	
Z	1.27		2.54	0.050		0.100

DIP14.TBL

# MC3303 - MC3403 - MC3503

## PACKAGE MECHANICAL DATA 14 PINS - PLASTIC MICROPACKAGE (SO)

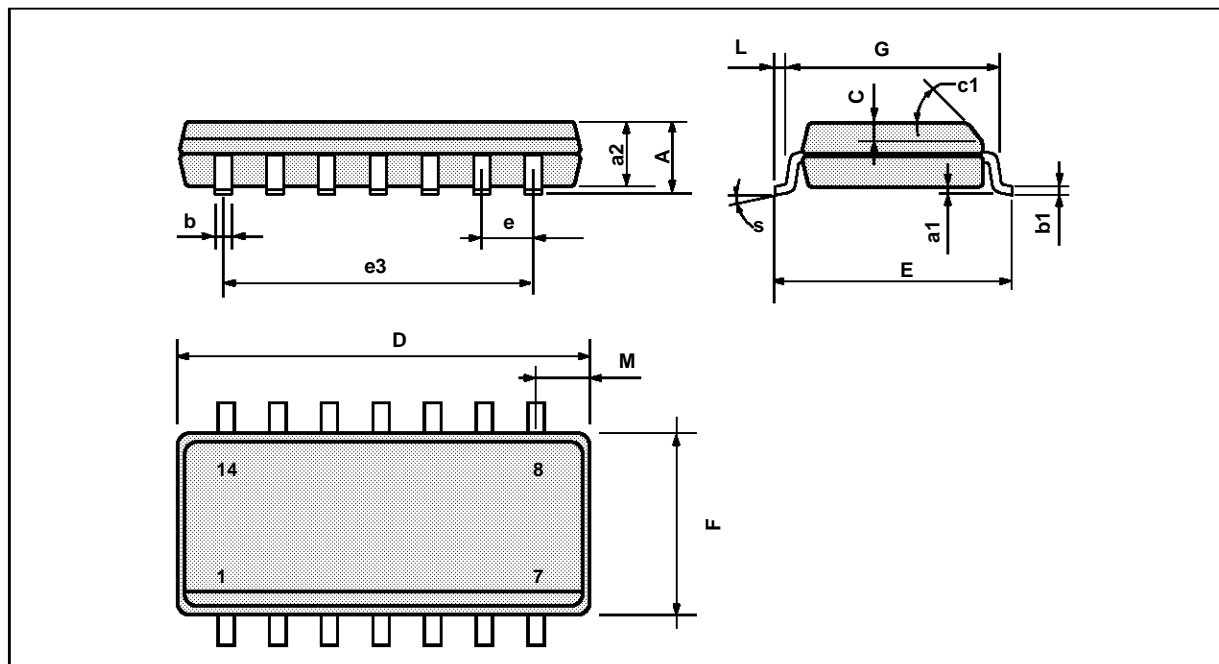

PM-SO14.EPS

Dimensions	Millimeters			Inches		
	Min.	Typ.	Max.	Min.	Typ.	Max.
A			1.75			0.069
a1	0.1		0.2	0.004		0.008
a2			1.6			0.063
b	0.35		0.46	0.014		0.018
b1	0.19		0.25	0.007		0.010
C		0.5			0.020	
c1	45° (typ.)					
D	8.55		8.75	0.336		0.334
E	5.8		6.2	0.228		0.244
e		1.27			0.050	
e3		7.62			0.300	
F	3.8		4.0	0.150		0.157
G	4.6		5.3	0.181		0.208
L	0.5		1.27	0.020		0.050
M			0.68			0.027
S	8° (max.)					

SO14.TBL

Information furnished is believed to be accurate and reliable. However, SGS-THOMSON Microelectronics assumes no responsibility for the consequences of use of such information nor for any infringement of patents or other rights of third parties which may result from its use. No licence is granted by implication or otherwise under any patent or patent rights of SGS-THOMSON Microelectronics. Specifications mentioned in this publication are subject to change without notice. This publication supersedes and replaces all information previously supplied. SGS-THOMSON Microelectronics products are not authorized for use as critical components in life support devices or systems without express written approval of SGS-THOMSON Microelectronics.

© 1994 SGS-THOMSON Microelectronics - All Rights Reserved

SGS-THOMSON Microelectronics GROUP OF COMPANIES

Australia - Brazil - France - Germany - Hong Kong - Italy - Japan - Korea - Malaysia - Malta - Morocco - The Netherlands  
Singapore - Spain - Sweden - Switzerland - Taiwan - Thailand - United Kingdom - U.S.A.

ORDER CODE: