

Medium power transistor (30V, 1.0A)

2SC5730

●Features

- 1) High speed switching. (T_f : Typ. : 35ns at $I_c = 1.0A$)
- 2) Low saturation voltage, typically
(Typ. : 150mV at $I_c = 500mA$, $I_B = 50mA$)
- 3) Strong discharge power for inductive load and capacitance load.
- 4) Complements the 2SA2048

●Applications

Small signal low frequency amplifier
High speed switching

●Structure

NPN Silicon epitaxial planar transistor

●Packaging specifications

Type	Package	Taping
	Code	TL
	Basic ordering unit (pieces)	3000
2SC5730		○

●External dimensions (Units : mm)

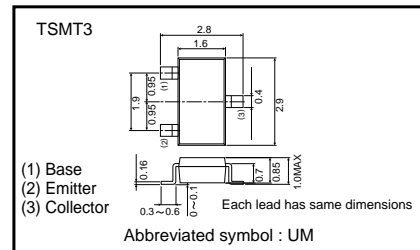

●Absolute maximum ratings ($T_a=25^\circ C$)

Parameter	Symbol	Limits	Unit
Collector-base voltage	V_{CB0}	30	V
Collector-emitter voltage	V_{CE0}	30	V
Emitter-base voltage	V_{EB0}	6	V
Collector current	I_c	1	A
	I_{cP}	2	A ^{*1}
Power dissipation	P_c	500	mW ^{*2}
Junction temperature	T_j	150	$^\circ C$
Range of storage temperature	T_{stg}	-55~+150	$^\circ C$

*1 $P_w=10ms$

*2 Each terminal mounted on a recommended land.

Transistor

●Electrical characteristics (Ta=25°C)

Parameter	Symbol	Min.	Typ.	Max.	Unit	Conditions
Collector-base breakdown voltage	BV _{CB0}	30	-	-	V	I _C =100μA
Collector-emitter breakdown voltage	BV _{CEO}	30	-	-	V	I _C =1mA
Emitter-base breakdown voltage	BV _{EBO}	6	-	-	V	I _E =100μA
Collector cut-off current	I _{CB0}	-	-	1.0	μA	V _{CB} =20V
Emitter cut-off current	I _{EBO}	-	-	1.0	μA	V _{EB} =4V
Collector-emitter saturation voltage	V _{CE(sat)}	-	150	300	mV	I _C =500mA, I _B =50mA
DC current gain	h _{FE}	120	-	390	-	V _{CE} =2V, I _C =100mA
Transition frequency	f _T	-	270	-	MHz	V _{CE} =10V, I _E =-100mA, f=10MHz*1
Collector output capacitance	C _{ob}	-	10	-	pF	V _{CB} =10V, I _E =0mA*2, f=1MHz
Turn-on time	T _{on}	-	30	-	ns	I _C =1A, I _{B1} =0.1A
Storage time	T _{stg}	-	120	-	ns	I _{B2} =-0.1A
Fall time	T _f	-	35	-	ns	V _{CC} ≈25V

*1 Non repetitive pulse

*2 See switching characteristics measurement circuits

●h_{FE} RANK

Q	R
120-270	180-390

●Electrical characteristic curves

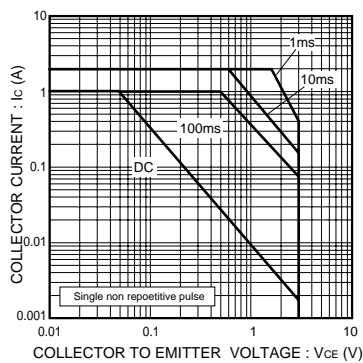

Fig.1 Safe operating area

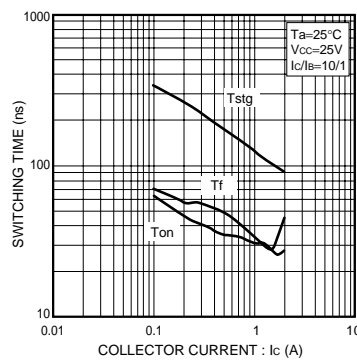

Fig.2 Switching Time

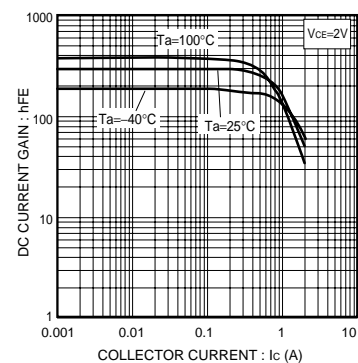

Fig.3 DC current gain vs. collector current

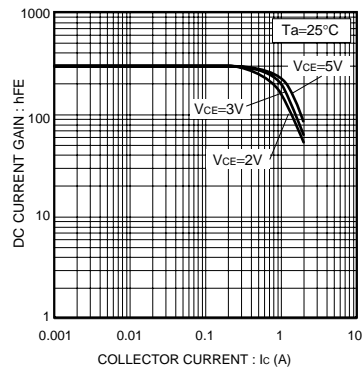

Fig.4 DC current gain vs. collector current

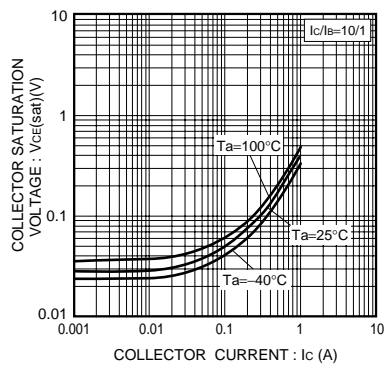

Fig.5 Collector-emitter saturation voltage vs. collector current

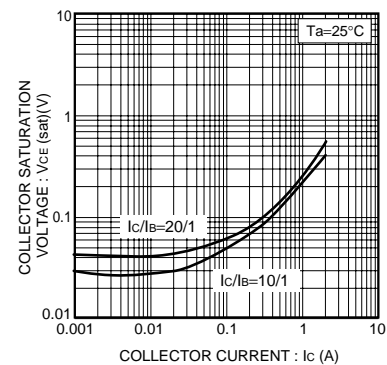

Fig.6 Collector-emitter saturation voltage vs. collector current

Transistor

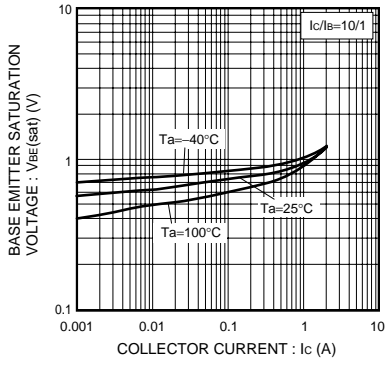

Fig.7 Base-emitter saturation voltage vs. collector current

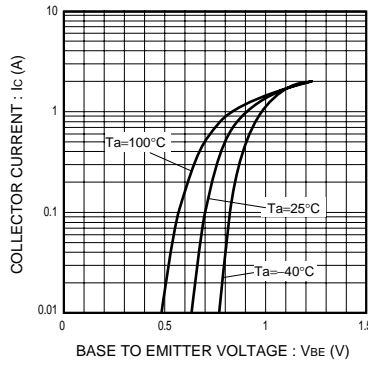

Fig.8 Ground emitter propagation characteristics

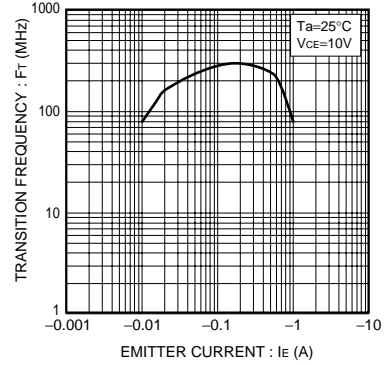

Fig.9 Transition frequency

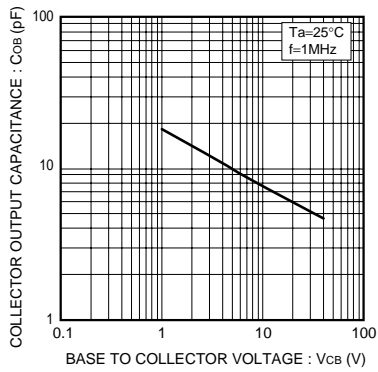
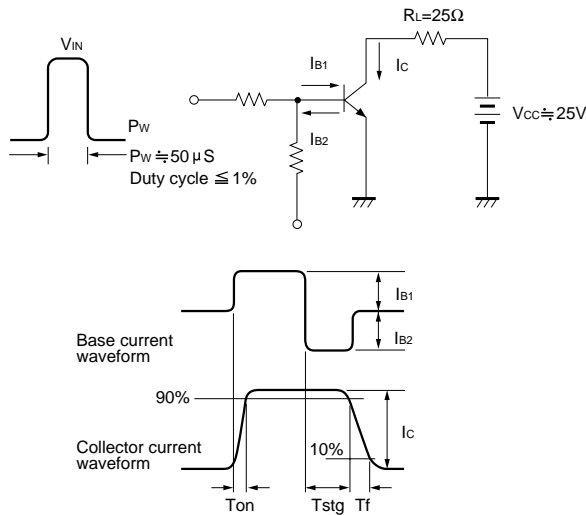

Fig.10 Collector output capacitance

●Switching characteristics measurement circuits





LittleDiode supplies new, hard to find or obsolete electronic components and semiconductors all over the world.

With over two million different components listed you are sure to find the part you need.

Feel free to visit us today at our online store:

LittleDiode.com

Looking forward to providing you with the best possible service.