

Description

- RF amplifier

Features

- High current transition frequency
 $f_T = 550\text{MHz (Typ.)}$, [$V_{CE} = 6\text{V}$, $I_E = -1\text{mA}$]
- Low output capacitance :
 $C_{ob} = 1.4\text{pF (Typ.)}$ [$V_{CB} = 6\text{V}$, $I_E = 0$]
- Low base time constant and high gain
- Excellent noise response

Ordering Information

Type NO.	Marking	Package Code
2SC5345	C5345	TO-92

Outline Dimensions

unit : mm

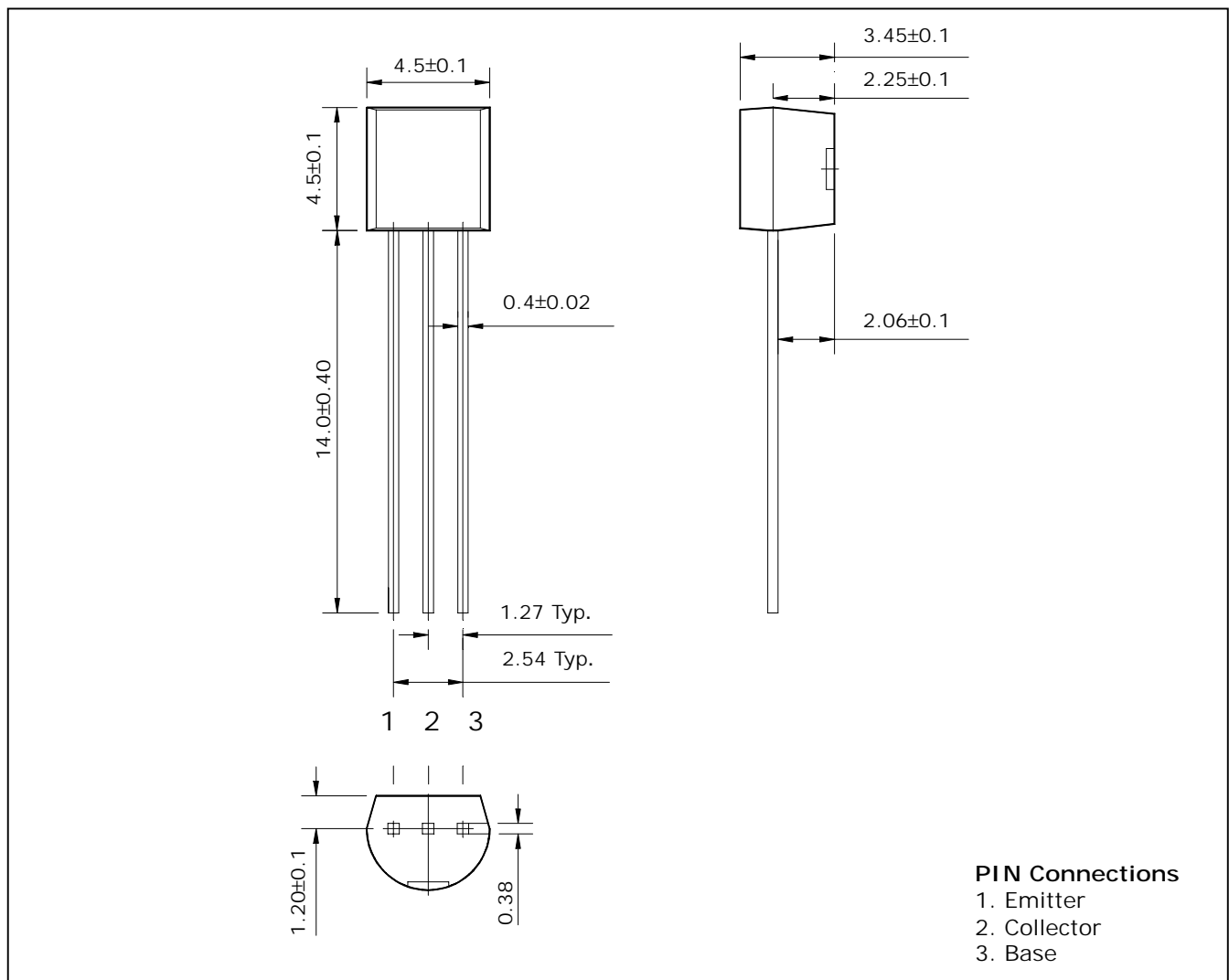

Absolute maximum ratings

Ta=25°C

Characteristic	Symbol	Ratings	Unit
Collector-Base voltage	V_{CBO}	30	V
Collector-Emitter voltage	V_{CEO}	20	V
Emitter-Base voltage	V_{EBO}	4	V
Collector current	I_C	20	mA
Collector dissipation	P_C	625	mW
Junction temperature	T_J	150	°C
Storage temperature range	T_{stg}	-55 ~ 150	°C

Electrical Characteristics

Ta=25°C

Characteristic	Symbol	Test Condition	Min.	Typ.	Max.	Unit
Collector-Base breakdown voltage	BV_{CBO}	$I_C=10\mu A, I_E=0$	30	-	-	V
Collector-Emitter breakdown voltage	BV_{CEO}	$I_C=5mA, I_B=0$	20	-	-	V
Emitter-Base breakdown voltage	BV_{EBO}	$I_E=10\mu A, I_C=0$	4	-	-	V
Collector cut-off current	I_{CBO}	$V_{CB}=30V, I_E=0$	-	-	0.5	μA
Emitter cut-off current	I_{EBO}	$V_{EB}=4V, I_C=0$	-	-	0.5	μA
DC current gain	h_{FE}^*	$V_{CE}=6V, I_C=1mA$	40	-	240	-
Collector-Emitter saturation voltage	$V_{CE(sat)}$	$I_C=10mA, I_B=1mA$	-	-	0.3	V
Transition frequency	f_T	$V_{CE}=6V, I_E=-1mA$	-	550	-	MHz
Collector output capacitance	C_{ob}	$V_{CB}=6V, I_E=0, f=1MHz$	-	1.4	-	pF

* : h_{FE} rank / R : 40~80, O : 70~140, Y : 120~240

Electrical Characteristic Curves

Fig. 1 $P_C - T_a$

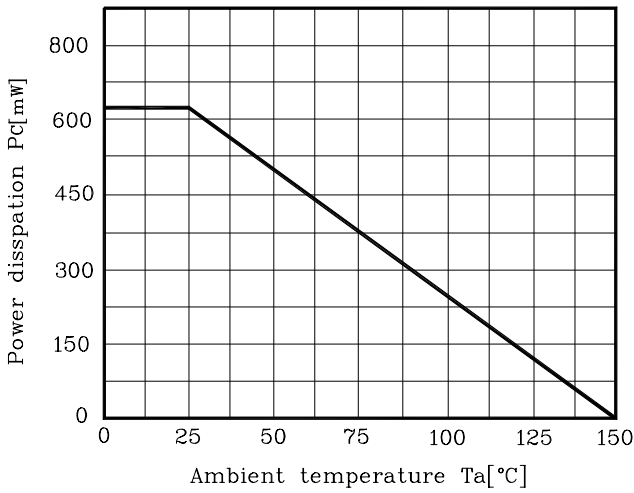

Fig. 2 $I_C - V_{CE}$

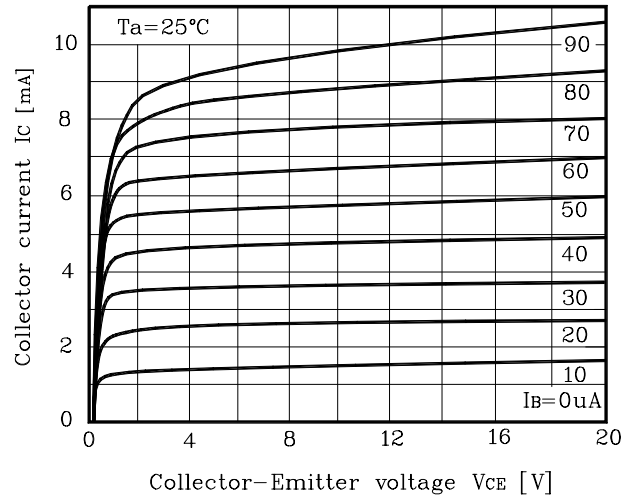

Fig. 3 $h_{FE} - I_C$

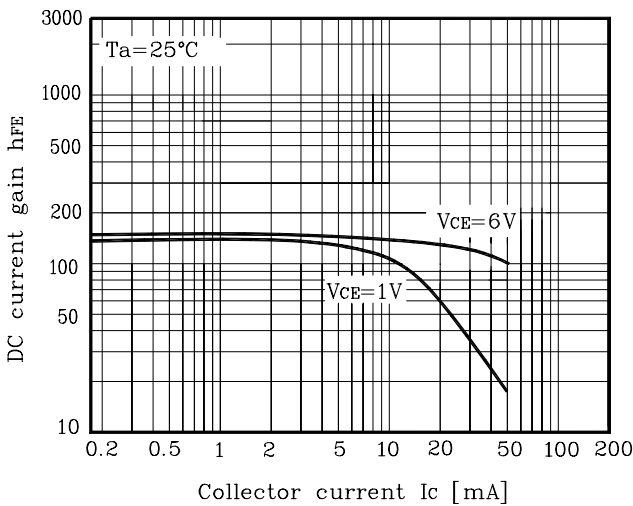

Fig. 4 $f_T - I_E$

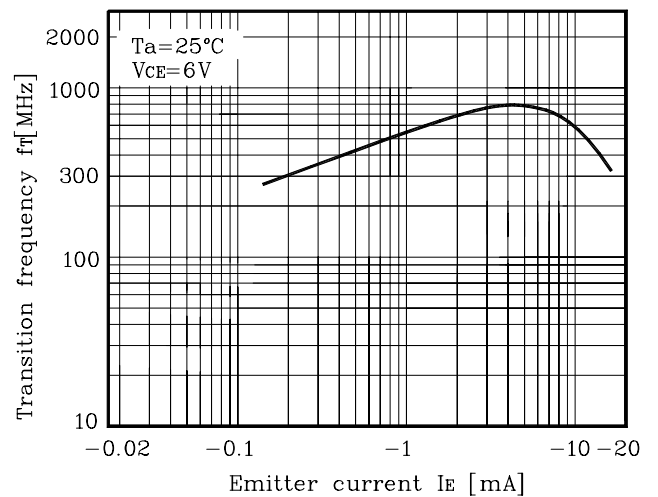

Fig. 5 $C_{ob} - V_{CB}$, $C_{ib} - V_{EB}$

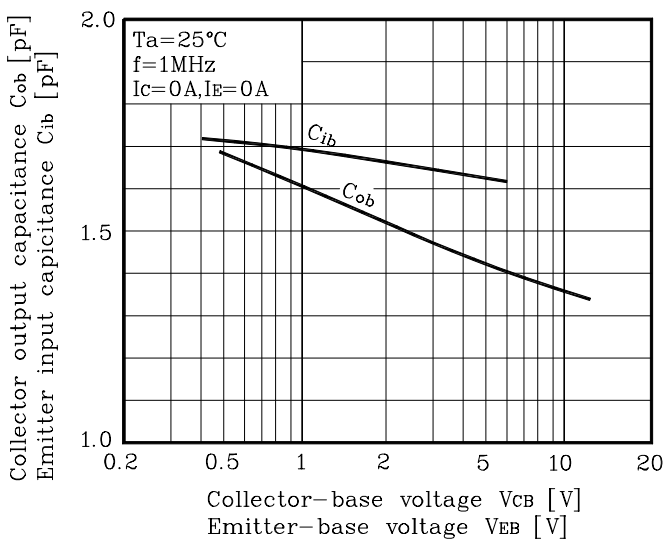
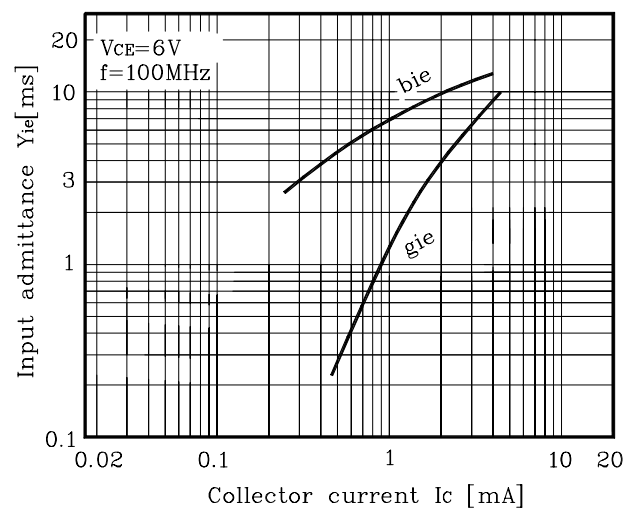

Fig. 6 $Y_{ie} - I_C$



Electrical Characteristic Curves

Fig. 7 I_C - Y_{oe}

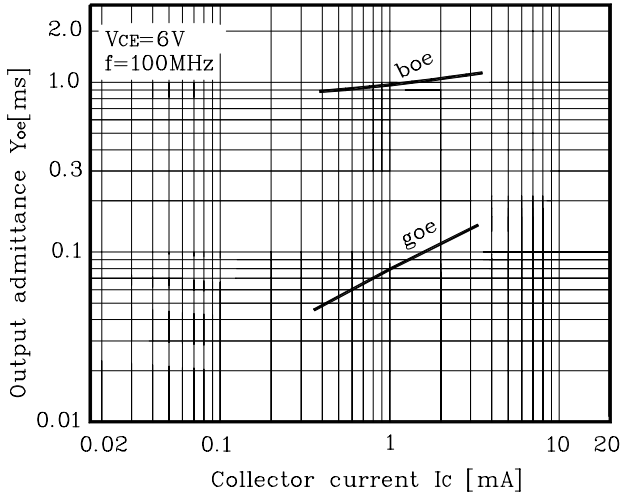

Fig. 8 I_C - Y_{fe}

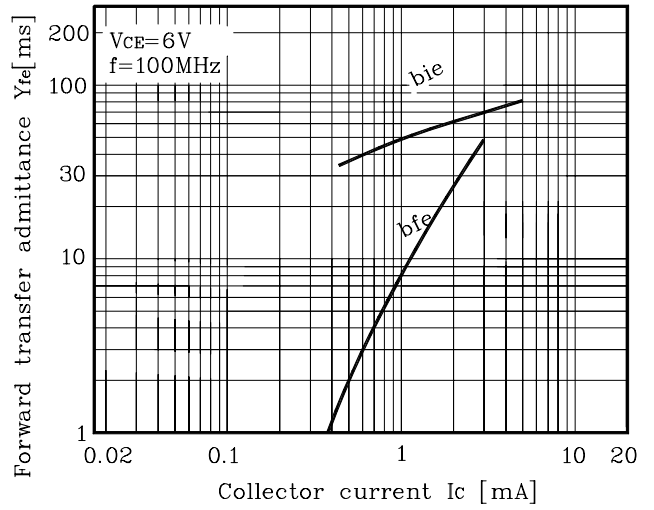
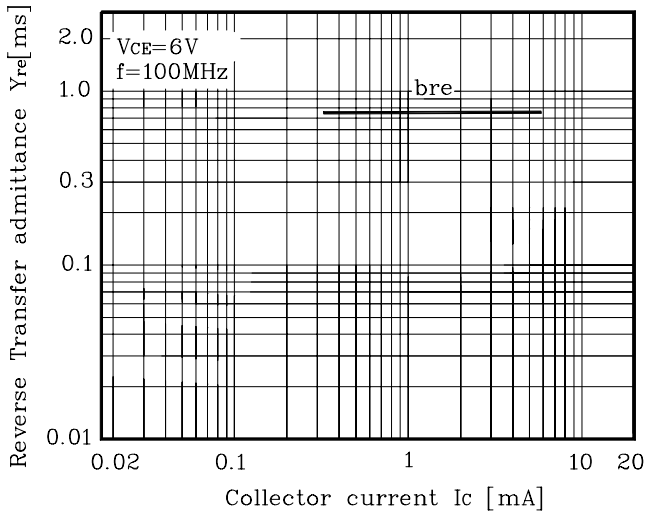

Fig. 9 I_C - Y_{re}





LittleDiode supplies new, hard to find or obsolete electronic components and semiconductors all over the world.

With over two million different components listed you are sure to find the part you need.

Feel free to visit us today at our online store:

LittleDiode.com

Looking forward to providing you with the best possible service.