

## CONTROL CIRCUIT FOR POWER SUPPLIES

The TDA2582 is a monolithic integrated circuit for controlling power supplies which are provided with the drive for the horizontal deflection stage.

The circuit features the following:

- Voltage controlled horizontal oscillator.
- Phase detector.
- Duty factor control for the negative-going transient of the output signal.
- Duty factor increases from zero to its normal operation value.
- Adjustable maximum duty factor.
- Over-voltage and over-current protection with automatic re-start after switch-off.
- Counting circuit for permanent switch-off when n-times over-current or over-voltage is sensed.
- Protection for open-reference voltage.
- Protection for too low supply voltage.
- Protection against loop faults.
- Positive tracking of duty factor and feedback voltage when the feedback voltage is smaller than the reference voltage minus 1,5 V.
- Normal and 'smooth' remote ON/OFF possibility.

### QUICK REFERENCE DATA

Supply voltage	V <sub>9-16</sub>	typ.	12 V
Supply current	I <sub>g</sub>	typ.	14 mA
<b>Input signals</b>			
Horizontal drive pulse (peak-to-peak value)	V <sub>3-16(p-p)</sub>		5 to 11 V
Flyback pulse (differentiated deflection current); peak-to-peak value	V <sub>2-16(p-p)</sub>		1 to 5 V
External reference voltage	V <sub>10-16</sub>	typ.	6,1 V
<b>Output signals</b>			
Duty factor of output pulse	$\delta$	> <	0 % 98 ± 0,8 %
Output voltage at I <sub>o</sub> < 20 mA (peak value)	V <sub>11-16M</sub>	typ.	11,8 V
Output current (peak value)	I <sub>11M</sub>	<	40 mA

### PACKAGE OUTLINES

TDA2582 : 16-lead DIL; plastic (SOT38).

TDA2582Q: 16-lead QIL; plastic (SOT58).

TDA2582  
TDA2582Q

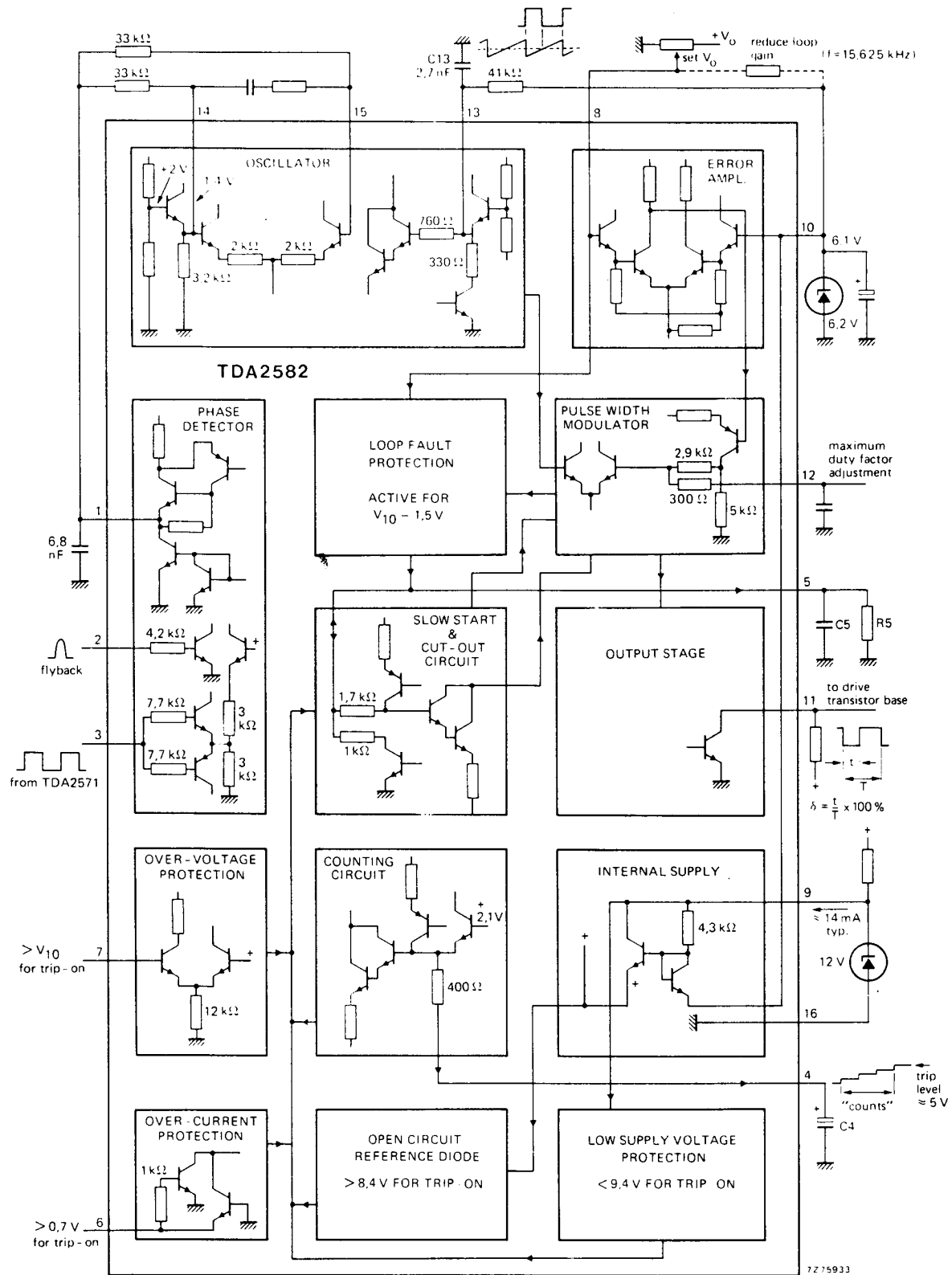

Fig. 1 Block diagram.

Note: trip levels are nominal values.

**RATINGS**

Limiting values in accordance with the Absolute Maximum System (IEC 134)

Supply voltage at pin 9	$V_{9-16}$	max.	14 V
Voltage at pin 11	$V_{11-16}$		0 to 14 V
Output current (peak value)	$I_{11M}$	max.	40 mA
Total power dissipation	$P_{tot}$	max.	280 mW
Storage temperature	$T_{stg}$		-25 to +125 °C
Operating ambient temperature	$T_{amb}$		-25 to +80 °C

**CHARACTERISTICS** $V_{9-16} = 12$  V;  $V_{10-16} = 6,1$  V;  $T_{amb} = 25$  °C; measured in Fig. 4

Supply voltage range	$V_{9-16}$	typ.	12 V 10 to 14 V
Protection voltage too low supply voltage	$V_{9-16}$	typ.	9,4 V 8,6 to 9,9 V
Supply current at $\delta = 50\%$	$I_g$	typ.	14 mA
Supply current during protection	$I_g$	typ.	14 mA
Minimum required supply current (note 1)	$I_g$	<	17 mA
Power consumption	$P$	typ.	170 mW

**Required input signals**

Reference voltage (note 2)	$V_{10-16}$	typ.	6,1 V 5,6 to 6,6 V
Feedback input impedance	$ Z_{8-16} $	typ.	200 k $\Omega$
High reference voltage protection: threshold voltage	$V_{10-16}$	typ.	8,4 V 7,9 to 8,9 V
Horizontal reference signal (square-wave or differentiated; negative transient is reference)			
Voltage driven (peak-to-peak value)	$V_{3-16(p-p)}$		5 to 12 V
Current driven (peak value)	$I_{3M}$		-1 to +1,5 mA
Switching level current	$\pm I_3$	<	100 $\mu$ A
Flyback pulse or differential deflection current	$V_{2-16}$		1 to 5 V
Flyback pulse current (peak value)	$I_{2M}$	<	1,5 mA
Over-current protection: (note 3)			
threshold voltage	$-V_{6-16}$	typ.	640 mV 600 to 695 mV
	$+V_{6-16}$	typ.	680 mV 640 to 735 mV

**Notes**

1. This value refers to the minimum required supply current that will start all devices under the following conditions:  $V_{9-16} = 10$  V;  $V_{10-16} = 6,2$  V;  $\delta = 50\%$ .
2. Voltage obtained via an external reference diode. Specified voltages do not refer to the nominal voltages of reference diodes.
3. This spread is inclusive temperature rise of the IC due to warming up. For other ambient temperatures the values must be corrected by using a temperature coefficient of typical  $-1,85$  mV/°C.

**CHARACTERISTICS (continued)**

Over-voltage protection:

( $V_{ref} = V_{10-16}$ ) threshold voltage	$V_{7-16}$	typ.	$V_{ref}-60$ mV
			$V_{ref}-130$ to $V_{ref}-0$ mV
Remote control voltage; switch-off (note 1)	$V_{4-16}$	>	5,6 V
Remote control voltage; switch-on	$V_{4-16}$	<	4,5 V
'Smooth' remote control; switch-off (note 2)	$V_{5-16}$	>	4,5 V
'Smooth' remote control; switch-on	$V_{5-16}$	<	3 V
Remote control switch-off current	$I_4$	<	1 mA

**Delivered output signals**

Horizontal drive pulse (loaded with a resistor of $560 \Omega$ to +12 V peak-to-peak value)	$V_{11-16(p-p)}$	>	11,6 V
Output current; peak value	$I_{11M}$	<	40 mA
Saturation voltage of output transistor at $I_{11} = 20$ mA	$V_{CEsat}$	typ.	200 mV
		<	400 mV
at $I_{11} = 40$ mA	$V_{CEsat}$	<	525 mV
Duty factor of output pulse (note 3)	$\delta$	>	0 %
		<	$98 \pm 0,8$ %
Charge current for capacitor on pin 4	$I_4$	typ.	110 $\mu$ A
Charge current for capacitor on pin 5	$I_5$	typ.	120 $\mu$ A
Supply current for reference	$I_{10}$	typ.	1 mA
			0,6 to 1,45 mA

**Oscillator**

Temperature coefficient		typ.	$0,0003$ $^{\circ}C^{-1}$
		<	$0,0004$ $^{\circ}C^{-1}$
Relative frequency deviation for $V_{10-16}$ changing from 5,6 to 6,6 V		typ.	-1,4 %
		<	-2 %
Oscillator frequency spread (with fixed external components)		<	3 %
Frequency control sensitivity at pin 15 $f_{nom} = 15,625$ kHz		typ.	5 kHz/V

**Notes**

- See application information pin 4.
- See application information pin 5.
- The duty factor is specified as follows:  $\delta = \frac{t_p}{T} \times 100\%$

(see Fig. 2). After switch-on the duty factor rises gradually from 0% to the steady value. The relationship between  $V_{8-16}$  and the duty factor is given in Fig. 7 and the relationship between  $V_{12-16}$  and the duty factor is shown in Fig. 9.

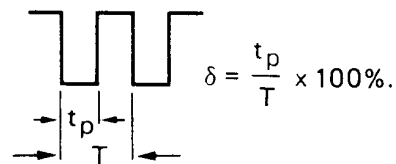

Fig. 2.

**Phase control loop**

Loop gain of APC-system (automatic phase control) *	typ.	5 kHz/ $\mu$ s
Catching range ( $f_{nom} = 15,625$ kHz)	$\Delta f >$	1300 Hz
	$\Delta f <$	2100 Hz
Phase relation between negative transient of sync pulse and middle of flyback	t typ.	1 $\mu$ s
Tolerance of phase relation	$\Delta t \leq$	$\pm 0,4 \mu$ s

**PINNING**

- |   |  |
|---|--|
| 1. Phase detector output  | 9. Positive supply                           |
| 2. Flyback pulse position input                                     | 10. Reference input                          |
| 3. Reference frequency input  | 11. Output                                   |
| 4. Re-start count capacitor/remote control input                    | 12. Maximum duty factor adjustment/smoothing |
| 5. Slow start and transfer characteristic for low feedback voltages | 13. Oscillator timing network                |
| 6. Over-current protection input                                    | 14. Reactance stage reference voltage        |
| 7. Over-voltage protection input                                    | 15. Reactance stage input                    |
| 8. Feedback voltage input   | 16. Negative supply (ground)                 |

\* For component values see Fig. 1.

APPLICATION INFORMATION

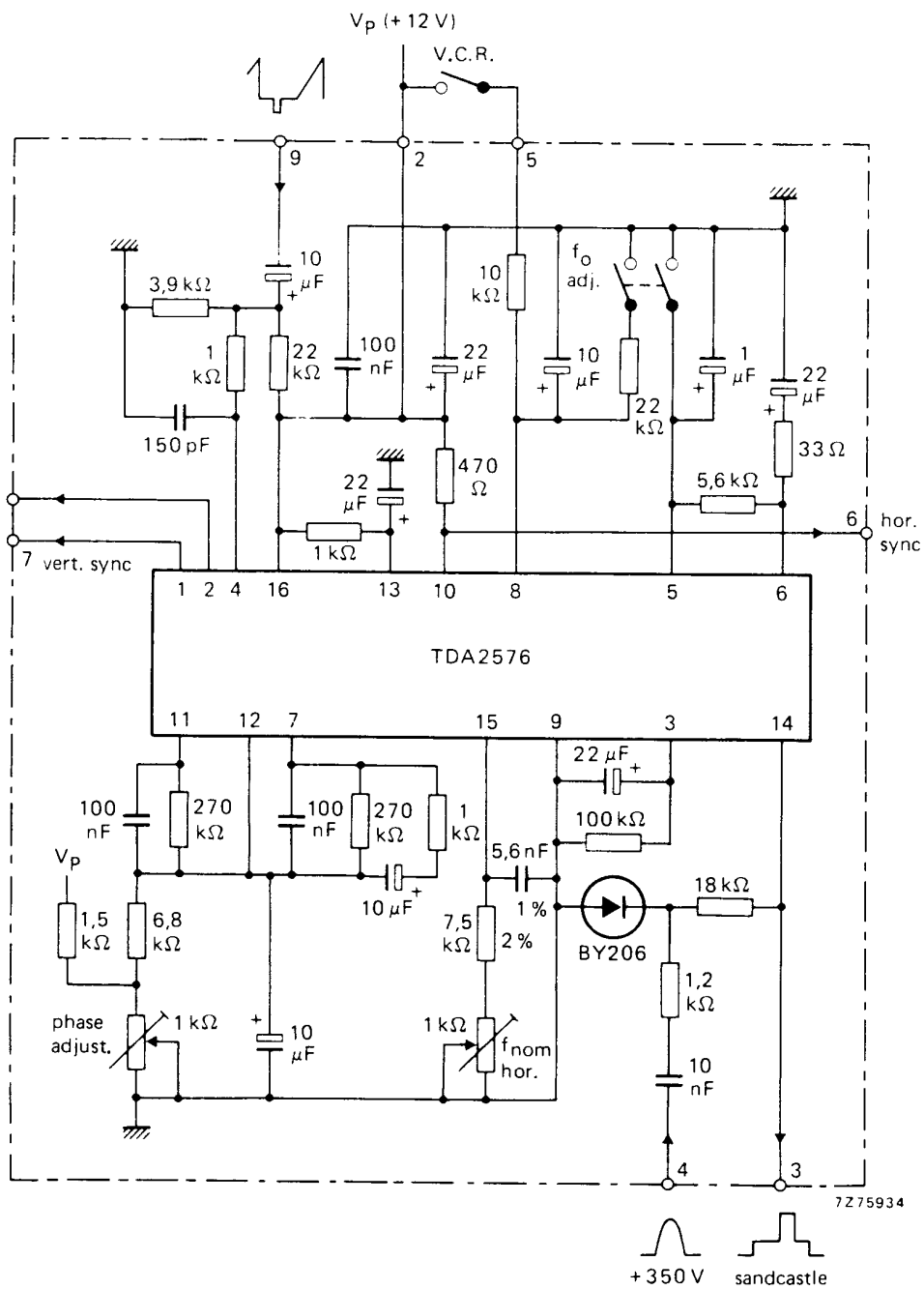

Fig. 3a.

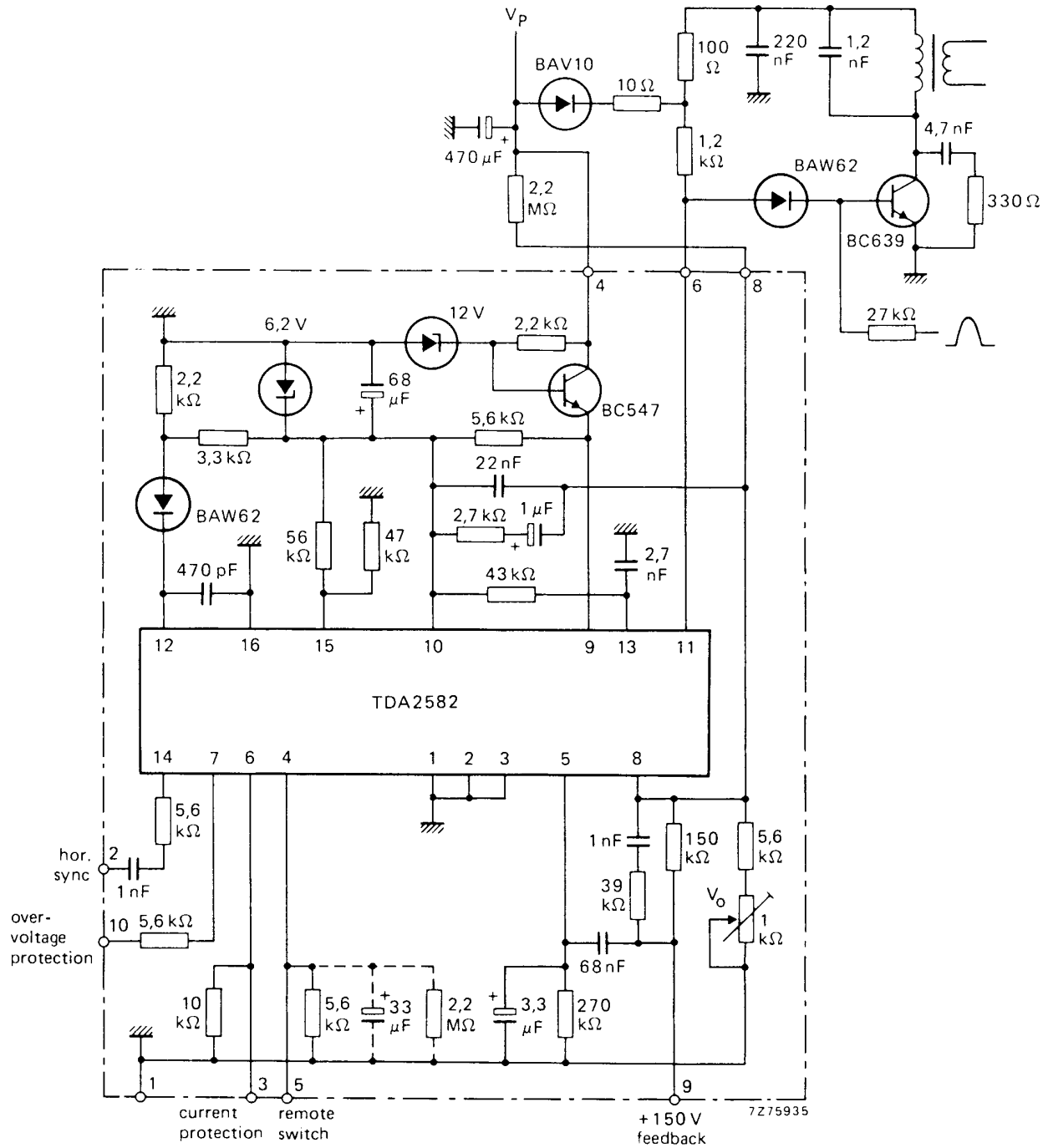

Fig. 3b.

Lead 6 (pin 10) of circuit TDA2576 connected to lead 2 (pin 14) of circuit TDA2582.

APPLICATION INFORMATION

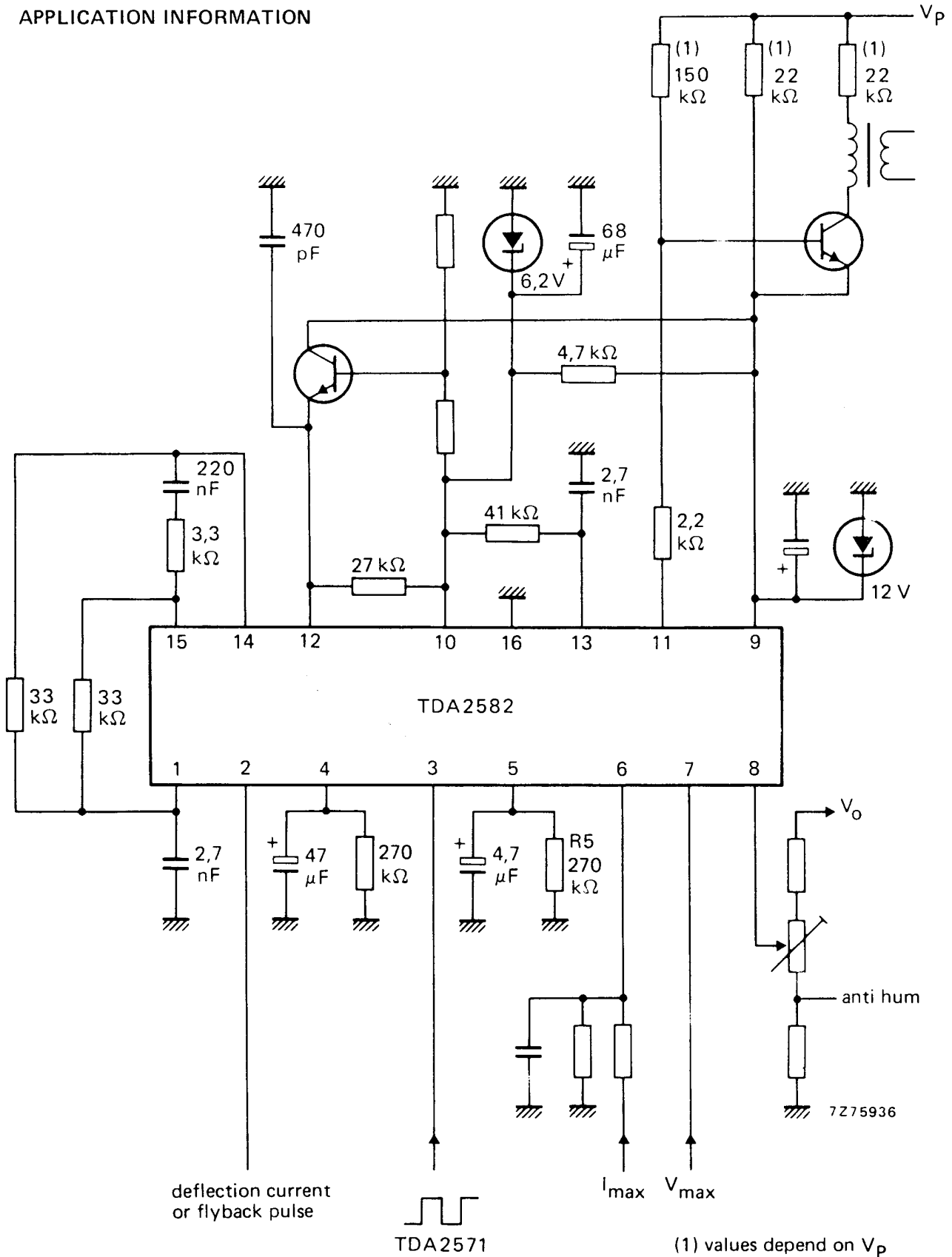

Fig. 4 Circuit diagram.

The function is described against the corresponding pin number

### 1. Phase detector output

The output circuit consists of a bidirectional current source which is active for the time that the signal on pin 2 exceeds 1 V.

The current values are chosen such that the correct phase relation is obtained when the output signal of the TDA2571 is applied to pin 3.

With a resistor of  $2 \times 33 \text{ k}\Omega$  and a capacitor of 2,7 nF the control steepness is  $0,55 \text{ V}/\mu\text{s}$  (Fig. 4).

### 2. Flyback pulse input

The signal applied to pin 2 is normally a flyback pulse with a duration of about  $12 \mu\text{s}$ . However, the phase detector system also accepts a signal derived by differentiating the deflection current by means of a small toroidal core (pulse duration  $> 3 \mu\text{s}$ ).

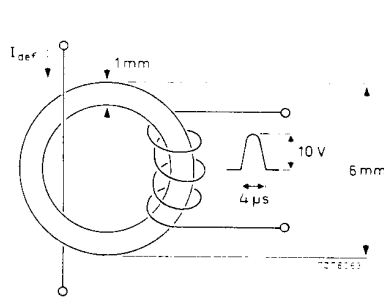

Fig. 5a.

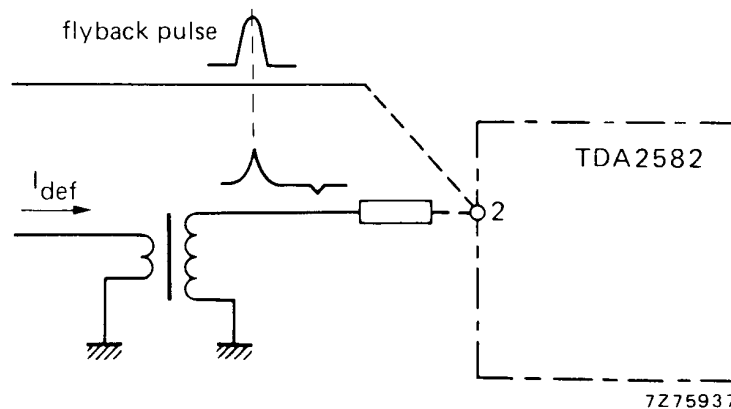

Fig. 5b.

The toroidal transformer in Fig. 5a is for obtaining a pulse representing the mid-flyback from the deflection current. The connection of the picture phase information is shown in Fig. 5b.

### 3. Reference frequency input

The input circuit can be driven directly by the square-wave output voltage from pin 8 of the TDA2571.

The negative-going transient switches the current source connected to pin 1 from positive to negative.

The input circuit is made such that a differentiated signal of the square-wave from the TDA2571 is also accepted (this enables mains isolation). The input circuit switching level is about 3 V and the input impedance is about  $8 \text{ k}\Omega$ .

### 4. Re-start count capacitor/remote control input

#### Counting

An external capacitor ( $C4 = 47 \mu\text{F}$ ) is connected between pins 4 and 16. This capacitor controls the characteristics of the protection circuits as follows.

If the protection circuits are required to operate, e.g. over-current at pin 6, the duty factor will be set to zero thus turning off the power supply.

After a short interval (determined by the time constant on pin 5) the power supply will be restarted via the slow start circuit.

If the fault condition has cleared, then normal operation will be resumed. If the fault condition is persistent, the duty factor of the pulses is again reduced to zero and the protection cycle is repeated.

The number of times this action is repeated ( $n$ ) for a persisting fault condition is now determined by:  $n = C4/C5$ .

## APPLICATION INFORMATION (continued)

### *Remote control input*

For this application the capacitor on pin 4 has to be replaced by a resistor with a value between 4,7 and 18 k $\Omega$ . When the externally applied voltage  $V_{4-16} > 5,6$  V, the circuit switches off; switching on occurs when  $V_{4-16} < 4,5$  V and the normal starting-up procedure is followed. Pin 4 is internally connected to an emitter-follower, with an emitter voltage of 1,5 V.

### 5. Slow start and transfer characteristics for low feedback voltages

#### *Slow start*

An external shunt capacitor ( $C_5 = 4,7 \mu\text{F}$ ) and resistor ( $R_5 = 270 \text{ k}\Omega$ ) are connected between pins 5 and 16. The network controls the rate at which the duty factor increases from zero to its steady-state value after switch-on. It provides protection against surges in the power transistor.

#### *Transfer characteristic for low feedback voltages*

The duty factor transfer characteristic for low feedback voltages can be influenced by  $R_5$ . The transfer for three different resistor values is given in Fig. 7.

#### *'Smooth' remote ON/OFF*

The ON/OFF information should be applied to pin 5 via a high ohmic resistor, a high OFF-level gives a slow rising voltage at pin 5, which results in a slowly decreasing duty factor.

### 6. Over-current protection input

A voltage proportional to the current in the power switching device is applied to the integrated circuit between pins 6 and 16. The circuit trips on both positive and negative polarity. When the tripping level is reached, the output pulse is immediately blocked and the starting circuit is activated again.

### 7. Over-voltage protection input

When the voltage applied to this pin exceeds the threshold level the protection circuit will operate. The tripping level is about the same as the reference voltage on pin 10.

### 8. Feedback voltage input

The control loop input is applied to pin 8. This pin is internally connected to one input of a differential amplifier, functioning as an amplitude comparator, the other input of which is connected to the reference source on pin 10.

Under normal operating conditions, the voltage on pin 8 will be about equal to the reference voltage on pin 10. For further information refer to the Figs 7 and 8.

### 9. 12 V positive supply

The maximum voltage that may be applied is 14 V. Where this is derived from an unstabilized supply rail, a regulator diode (12 V) should be connected between pins 9 and 16 to ensure that the maximum voltage does not exceed 14 V. When the voltage on this pin falls below a minimum of 8,6 V (typically 9,4 V), the protection circuit will switch-off the power supply.

**10. Reference input**

An external reference diode must be connected between this pin and pin 16.

The reference voltage must be between 5,6 and 6,6 V. The IC delivers about 1 mA into the external regulator diode. When the external load on the regulator diode approaches this current, replenishment of the current can be obtained by connecting a suitable resistor between pins 9 and 10. A higher reference voltage value up to 7,5 V is allowed when use is made of a duty factor limiting resistor  $< 27 \text{ k}\Omega$  between pins 12 and 16.

**11. Output**

An external resistor determines the output current fed into the base of the driver transistor. The output circuit uses an n-p-n transistor with 3 series-connected clamping diodes to the internal 12 V supply rail. This provides a low impedance in the "ON" state, that is with the drive transistor turned-off.

**12. Maximum duty factor adjustment/smoothing***Maximum duty factor adjustment*

Pin 12 is connected to the output voltage of the amplitude comparator ( $V_{10.8}$ ). This voltage is internally connected to one input of a differential amplifier, the other input of which is connected to the sawtooth voltage of the horizontal oscillator. A high voltage on pin 12 results in a low duty factor. This enables the maximum duty factor to be adjusted by limiting the voltage by connecting pin 12 to the emitter of an n-p-n transistor used as a voltage source.

Fig. 9 plots the maximum duty factor as a function of the voltage applied to pin 12. If some spread is acceptable the maximum duty factor can also be limited by connecting a resistor from pin 12 to pin 16. A resistor of  $12 \text{ k}\Omega$  limits the maximum duty factor to about 50%. This application also reduces the total IC gain.

*Smoothing*

Any double pulsing of the IC due to circuit layout can be suppressed by connecting a capacitor of about  $470 \text{ pF}$  between pins 12 and 16.

**13. Oscillator timing network**

The timing network comprises a capacitor between pins 13 and 16, and a resistor between pin 13 and the reference voltage on pin 10.

The charging current for the capacitor (C13) is derived from the voltage reference diode connected to pin 10 and discharged via an internal resistor of about  $330 \Omega$ .

**14. Reactance stage reference voltage**

This pin is connected to an emitter follower which determines the nominal reference voltage for the reactance stage ( $1,4 \text{ V}$  for reference voltage  $V_{10.16} = 6,1 \text{ V}$ ). Free-running frequency is obtained when pins 14 and 15 are short-circuited.

**15. Reactance stage input**

The output voltage of the phase detector (pin 1) is connected to pin 15 via a resistor. The voltage applied to pin 15 shifts the upper level of the voltage sensor of the oscillator thus changing the oscillator frequency and phase. The time constant network is connected between 14 and 15. Control sensitivity is typically  $5 \text{ kHz/V}$ .

**16. Negative supply (ground)**

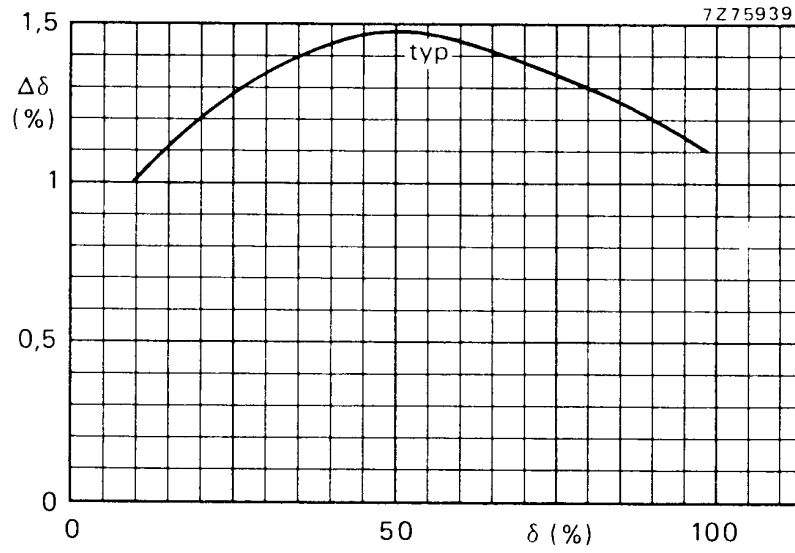

Fig. 6 Duty factor change as a function of initial duty factor; at 1 mV error amplifier input change;  $\Delta V_{8-10(p-p)} = 1$  mV.

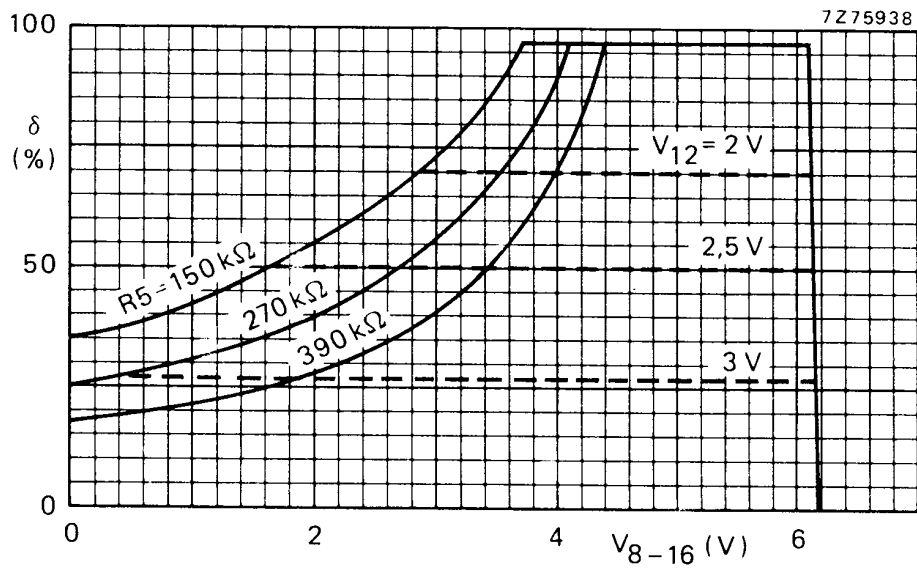

Fig. 7 Duty factor of output pulses as a function of feedback input voltage ( $V_{8-16}$ ) with  $R_5$  as a parameter and  $V_{12-16}$  as a limiting value;  $V_{10-16} = 6,1$  V.

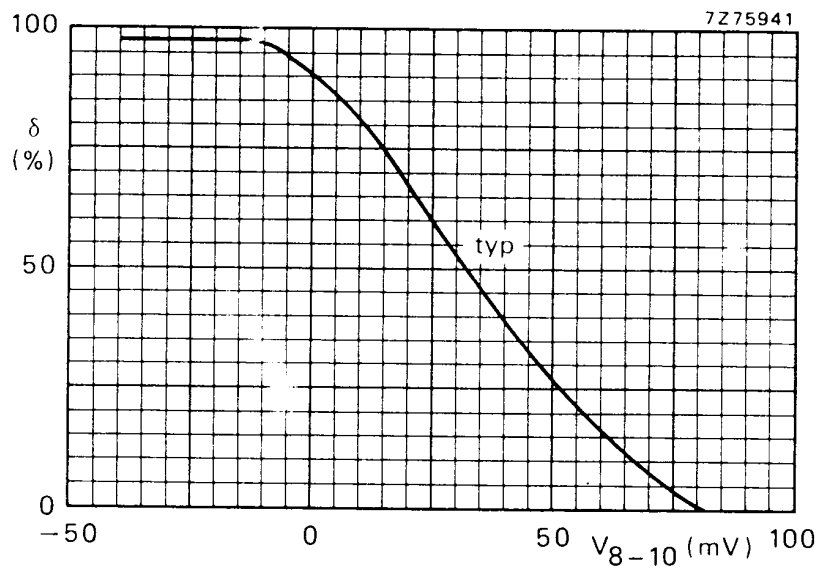

Fig. 8 Duty factor of output pulses as a function of error amplifier input ( $V_{8-10}$ );  $V_{10-16} = 6,1$  V.

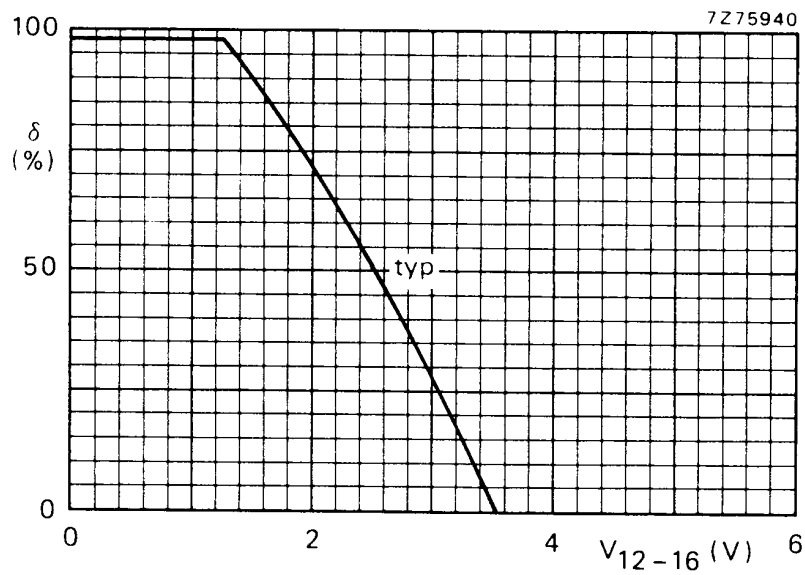

Fig. 9 Maximum duty factor limitation as a function of the voltage applied to pin 12;  $V_{10-16} = 6,1$  V.