

SILICON TRANSISTOR
2SC4178

HIGH FREQUENCY AMPLIFIER
NPN SILICON EPITAXIAL TRANSISTOR

PACKAGE DIMENSIONS
in millimeters

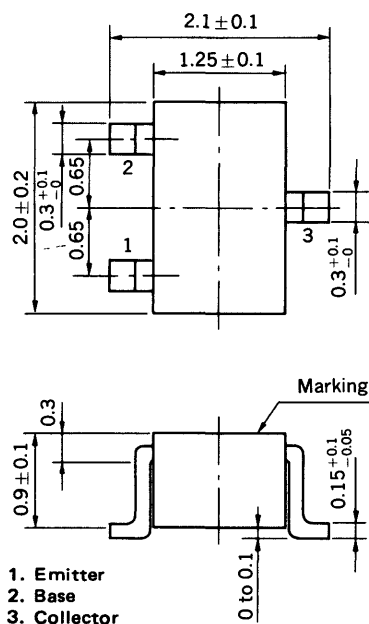

DESCRIPTION

The 2SC4178 is designed for use in small type equipments especially recommended for Hybrid Integrated Circuit and other applications.

FEATURES

- Micro package.
- High gain bandwidth product. $f_T = 600 \text{ MHz TYP. } (I_E = -1.0 \text{ mA})$
- Low output capacitance. $C_{ob} = 1.0 \text{ pF TYP. } (V_{CB} = 6.0 \text{ V})$

ABSOLUTE MAXIMUM RATINGS ($T_a = 25^\circ\text{C}$)

Maximum Voltages and Current

Collector to Base Voltage	V_{CBO}	30	V
Collector to Emitter Voltage	V_{CEO}	20	V
Emitter to Base Voltage	V_{EBO}	4.0	V
Collector Current	I_C	20	mA

Maximum Power Dissipation

Total Power Dissipation	P_T	150	mW
-------------------------	-------	-----	----

Maximum Temperatures

Storage Temperature	T_{stg}	-55 to +150	$^\circ\text{C}$
Junction Temperature	T_j	150	$^\circ\text{C}$

ELECTRICAL CHARACTERISTICS ($T_a = 25^\circ\text{C}$)

CHARACTERISTIC	SYMBOL	MIN.	TYP.	MAX.	UNIT	TEST CONDITIONS
Collector Cutoff Current	I_{CBO}			100	nA	$V_{CB} = 30 \text{ V, } I_E = 0$
DC Current Gain	h_{FE}	40	90	180		$V_{CE} = 6.0 \text{ V, } I_C = 1.0 \text{ mA}$
Collector Saturation Voltage	$V_{CE(sat)}$		0.1	0.3	V	$I_C = 10 \text{ mA, } I_B = 1.0 \text{ mA}$
Gain Bandwidth Product	f_T	400	600		MHz	$V_{CE} = 6.0 \text{ V, } I_E = -1.0 \text{ mA}$
Output Capacitance	C_{ob}		1.0		pF	$V_{CB} = 6.0 \text{ V, } I_E = 0, f = 1.0 \text{ MHz}$
Collector to Base Time Constant	$C_c \cdot r_{b'b}$		12		ps	$V_{CE} = 6.0 \text{ V, } I_E = -1.0 \text{ mA, } f = 31.9 \text{ MHz}$
Noise Figure	NF		3.0		dB	$V_{CE} = 6.0 \text{ V, } I_E = -1.0 \text{ mA, } R_G = 50 \Omega, f = 100 \text{ MHz}$ See Test Circuit

Classification of h_{FE}

Marking	F12	F13	F14
h_{FE} Range	40 to 80	60 to 120	90 to 180

TYPICAL CHARACTERISTICS ($T_a = 25^\circ\text{C}$ unless otherwise noted)

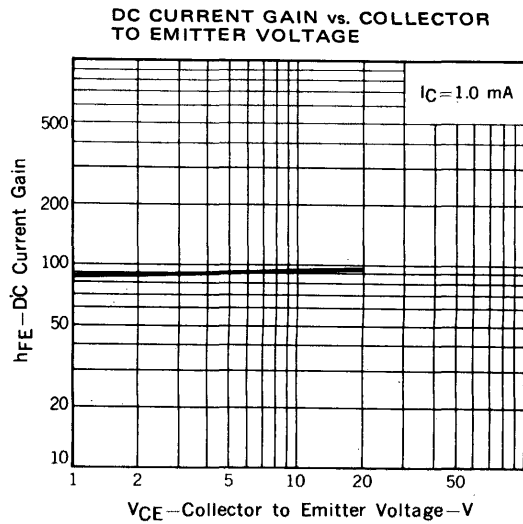
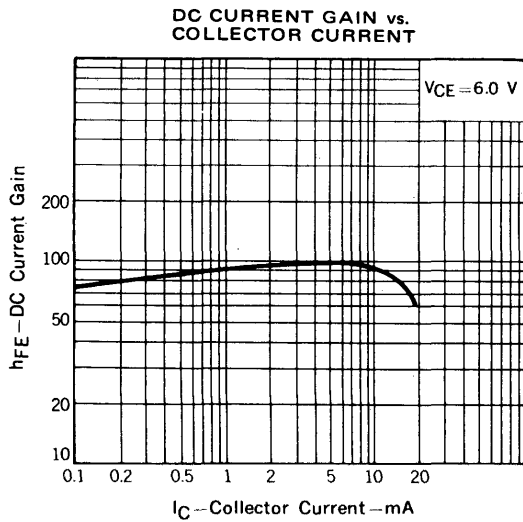
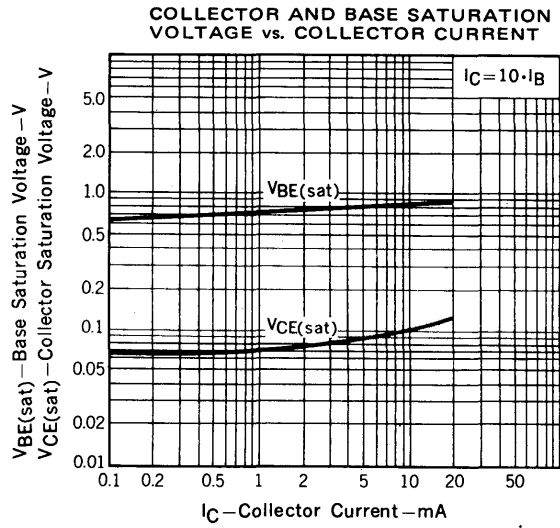
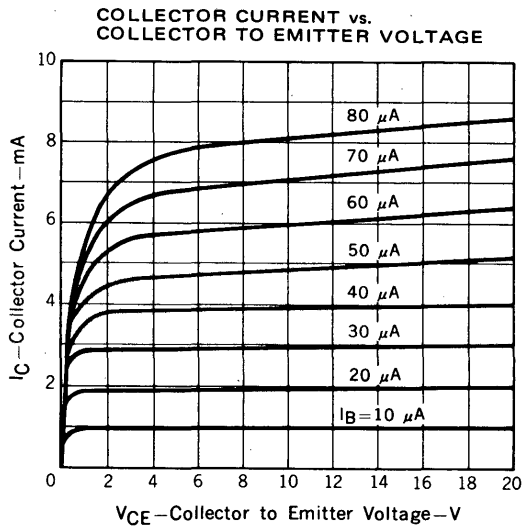
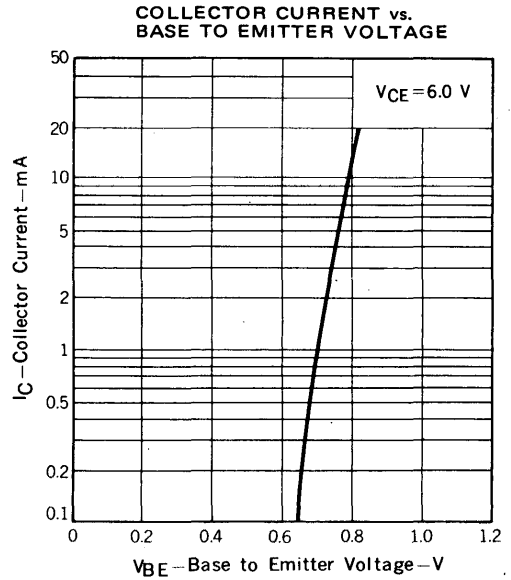
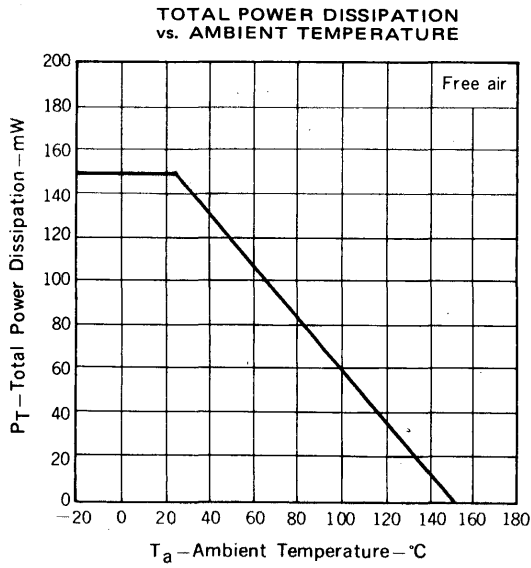

GAIN BANDWIDTH PRODUCT vs. EMITTER CURRENT

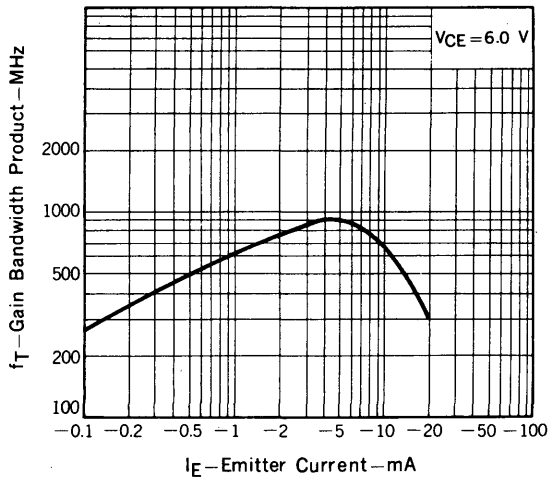

INPUT CAPACITANCE vs. EMITTER TO BASE VOLTAGE, OUTPUT CAPACITANCE vs. COLLECTOR TO BASE VOLTAGE

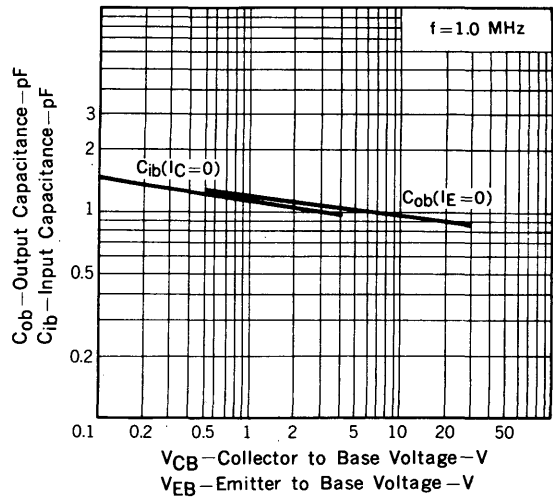

COLLECTOR TO BASE TIME CONSTANT vs. EMITTER CURRENT

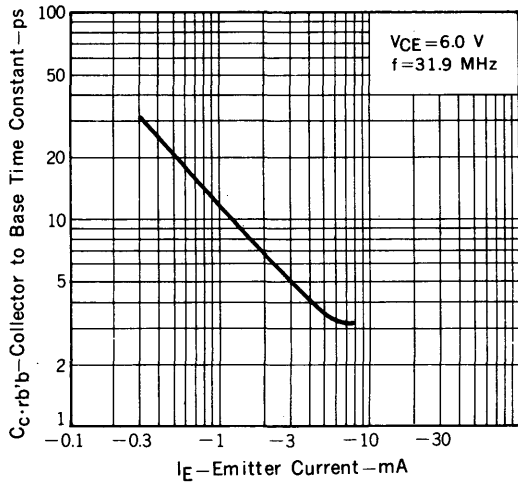

POWER GAIN, NOISE FIGURE vs. EMITTER CURRENT

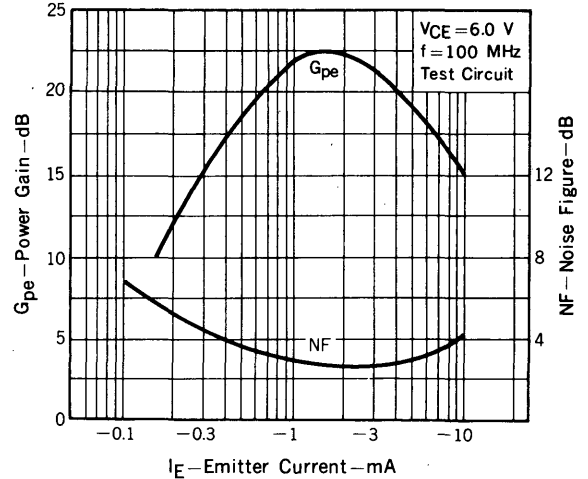

100 MHz G_{pe} , NF TEST CIRCUIT

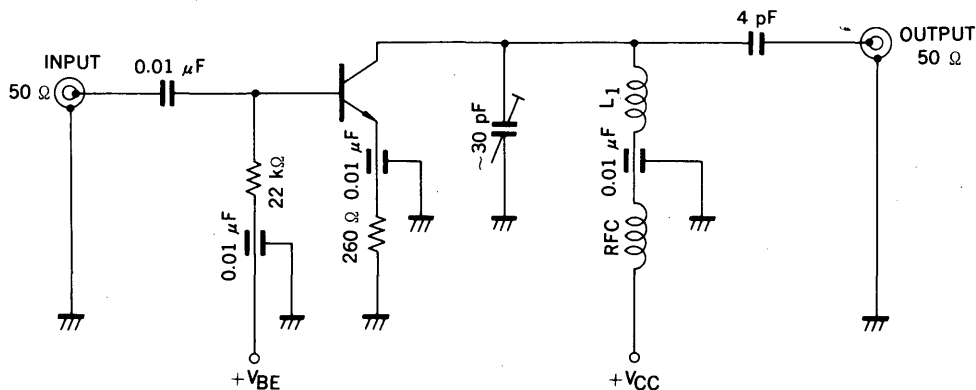



LittleDiode supplies new, hard to find or obsolete electronic components and semiconductors all over the world.

With over two million different components listed you are sure to find the part you need.

Feel free to visit us today at our online store:

LittleDiode.com

Looking forward to providing you with the best possible service.