

SILICON TRANSISTOR
2SC4173

HIGH FREQUENCY AMPLIFIER AND SWITCHING
NPN SILICON EPITAXIAL TRANSISTOR

PACKAGE DIMENSIONS

in millimeters

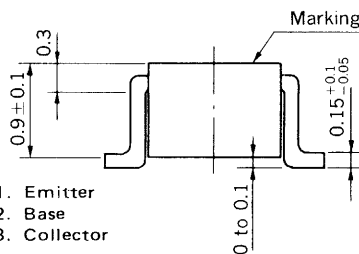
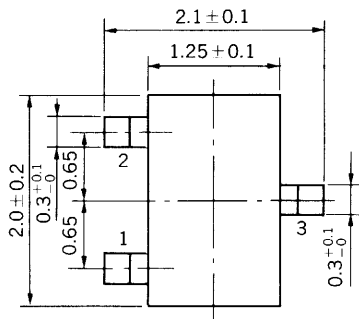

- 1. Emitter
- 2. Base
- 3. Collector

FEATURES

- High Gain Bandwidth Product: $f_T = 200$ MHz MIN.
- Complementary to 2SA1608

ABSOLUTE MAXIMUM RATINGS

Maximum Voltages and Current ($T_a = 25^\circ\text{C}$)

Collector to Base Voltage	V_{CB0}	60	V
Collector to Emitter Voltage	V_{CEO}	40	V
Emitter to Base Voltage	V_{EBO}	5.0	V
Collector Current (DC)	I_C	500	mA

Maximum Power Dissipation

Total Power Dissipation			
at 25°C Ambient Temperature	P_T	150	mW

Maximum Temperatures

Junction Temperature	T_j	150	$^\circ\text{C}$
Storage Temperature Range	T_{stg}	-55 to +150	$^\circ\text{C}$

ELECTRICAL CHARACTERISTICS ($T_a = 25^\circ\text{C}$)

CHARACTERISTIC	SYMBOL	MIN.	TYP.	MAX.	UNIT	TEST CONDITIONS
Collector Cutoff Current	I_{CB0}			100	nA	$V_{CB} = 40\text{ V}, I_E = 0$
Emitter Cutoff Current	I_{EBO}			100	nA	$V_{EB} = 4.0\text{ V}, I_C = 0$
DC Current Gain	h_{FE1}	75	150	300		$V_{CE} = 1.0\text{ V}, I_C = 150\text{ mA}$
DC Current Gain	h_{FE2}	20	75			$V_{CE} = 2.0\text{ V}, I_C = 500\text{ mA}$
Collector Saturation Voltage	$V_{CE(sat)}$		0.25	0.75	V	$I_C = 500\text{ mA}, I_B = 50\text{ mA}$
Base Saturation Voltage	$V_{BE(sat)}$		1.0	1.2	V	$I_C = 500\text{ mA}, I_B = 50\text{ mA}$
Gain Bandwidth Product	f_T	200	400		MHz	$V_{CE} = 10\text{ V}, I_E = -20\text{ mA}$
Output Capacitance	C_{ob}		3.5	8.0	pF	$V_{CB} = 10\text{ V}, I_E = 0, f = 1.0\text{ MHz}$
Turn-on Time	t_{on}		30		ns	$V_{CC} = 30\text{ V}$
Storage Time	t_{stg}		150		ns	$I_C = 150\text{ mA}$
Turn-off Time	t_{off}		180		ns	$I_{B1} = -I_{B2} = 15\text{ mA}$

* Pulsed: $PW \leq 350\ \mu\text{s}$, Duty Cycle $\leq 2\%$

h_{FE} Classification

Marking	B12	B13	B14
h_{FE1}	75 to 150	100 to 200	150 to 300

SWITCHING TIME TEST CIRCUIT

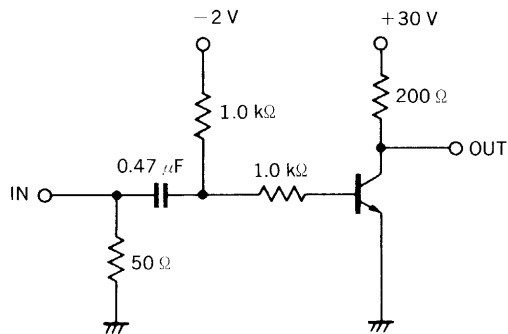

t_{on} SWITCHING

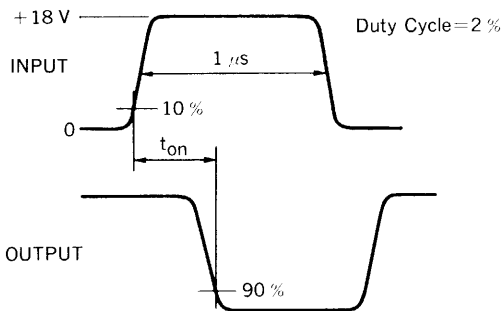

VOLTAGE WAVEFORMS

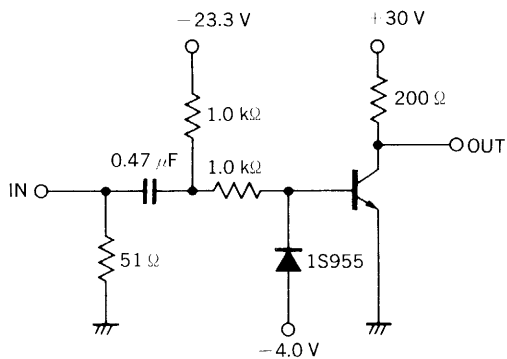

t_{off} SWITCHING

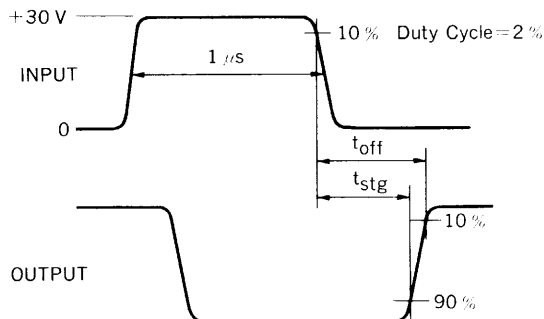

VOLTAGE WAVEFORMS

TYPICAL CHARACTERISTICS ($T_a = 25^\circ\text{C}$)

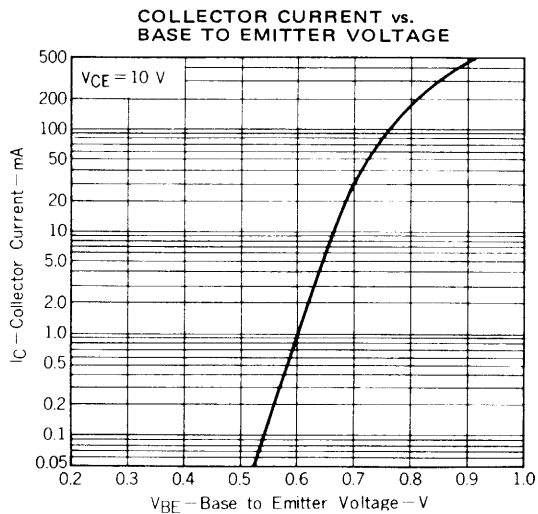
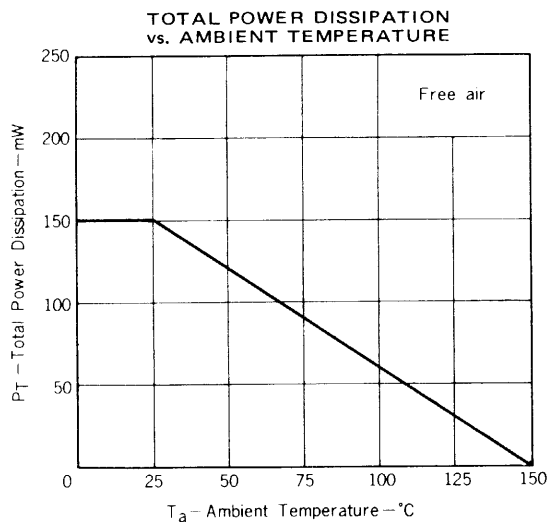

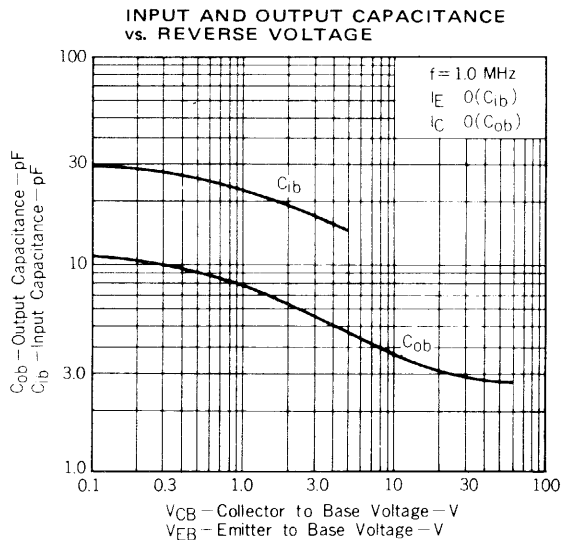
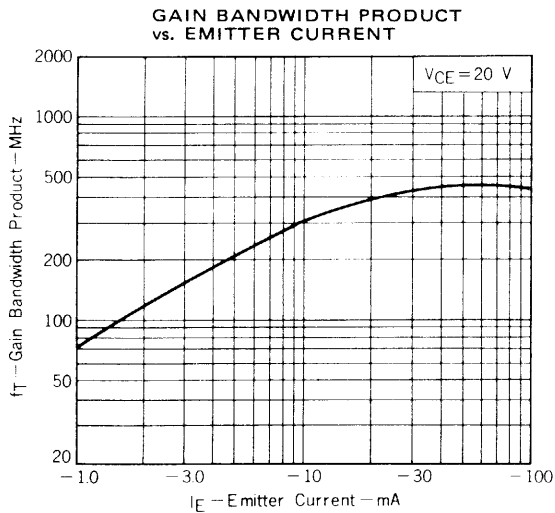
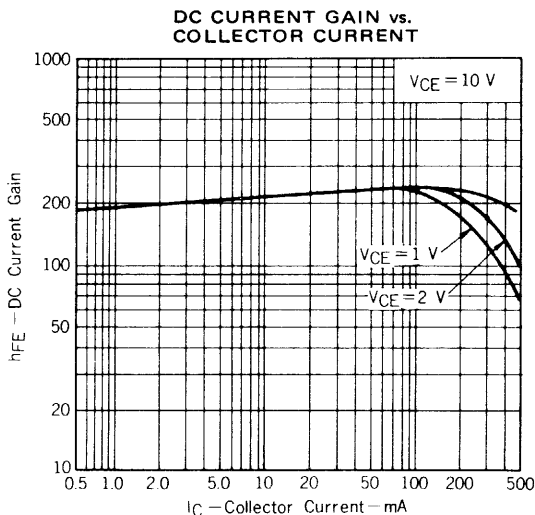
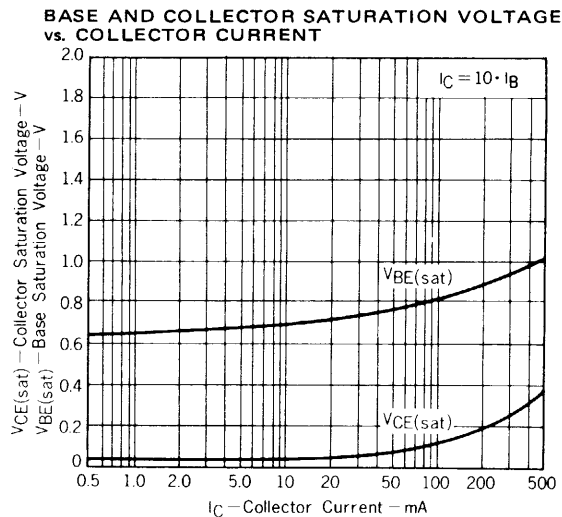
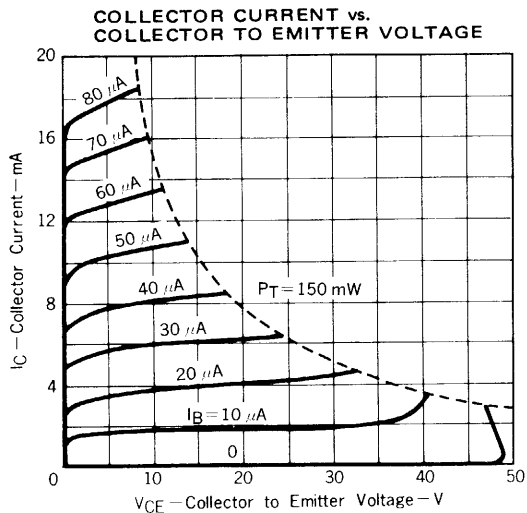

DELAY TIME vs. COLLECTOR CURRENT

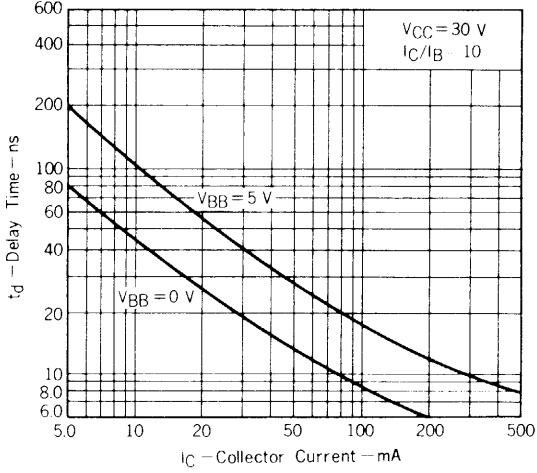

RISE TIME vs. COLLECTOR CURRENT

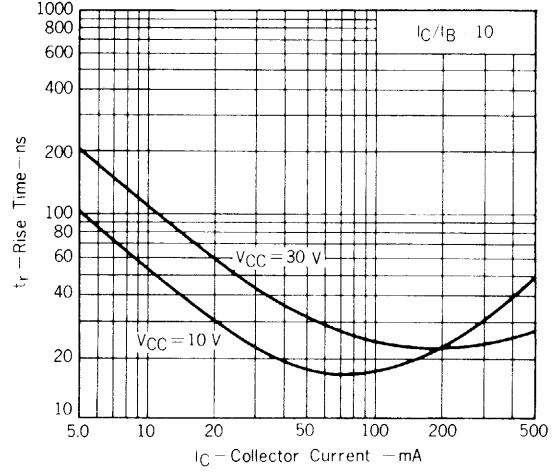

STORAGE TIME vs. COLLECTOR CURRENT

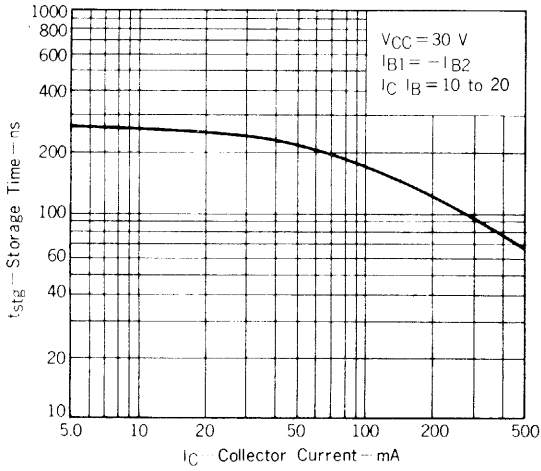

FALL TIME vs. COLLECTOR CURRENT

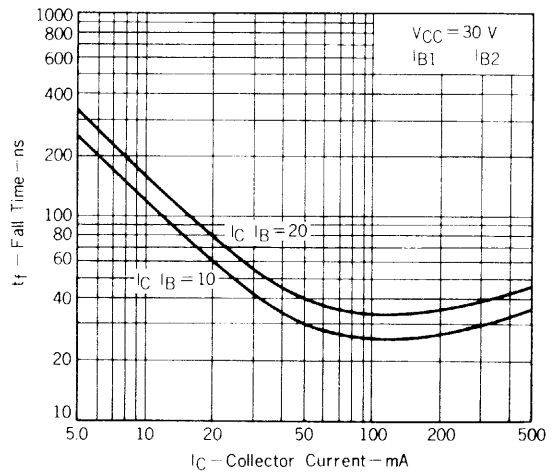



LittleDiode supplies new, hard to find or obsolete electronic components and semiconductors all over the world.

With over two million different components listed you are sure to find the part you need.

Feel free to visit us today at our online store:

LittleDiode.com

Looking forward to providing you with the best possible service.