

**DUAL 5.1V REGULATOR WITH DISABLE AND RESET**

- OUTPUT CURRENTS UP TO 1A
- FIXED PRECISION OUTPUT VOLTAGES  
5.1V ± 2%
- OUTPUT 1 WITH RESET FACILITY
- OUTPUT 2 WITH DISABLE BY TTL INPUT
- SHORT CIRCUIT PROTECTION AT BOTH  
OUTPUTS
- THERMAL PROTECTION
- LOW DROP OUTPUT VOLTAGE

**DESCRIPTION**

The TDA8137 is a monolithic dual positive voltage regulator designed to provide fixed precision output voltages of 5.1V at currents up to 1A.

An internal reset circuit generates a reset pulse when the output 1 decreases below the regulated voltage value.

Output 2 can be disabled by TTL input.

Short circuit and thermal protections are included.

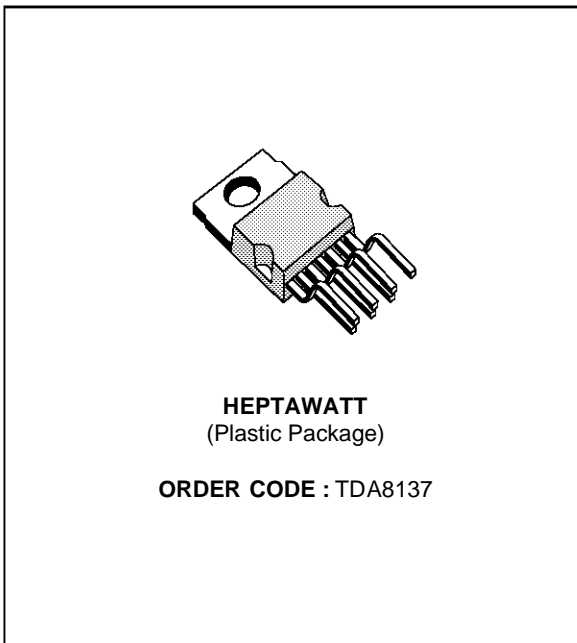

**PIN CONNECTION (top view)**

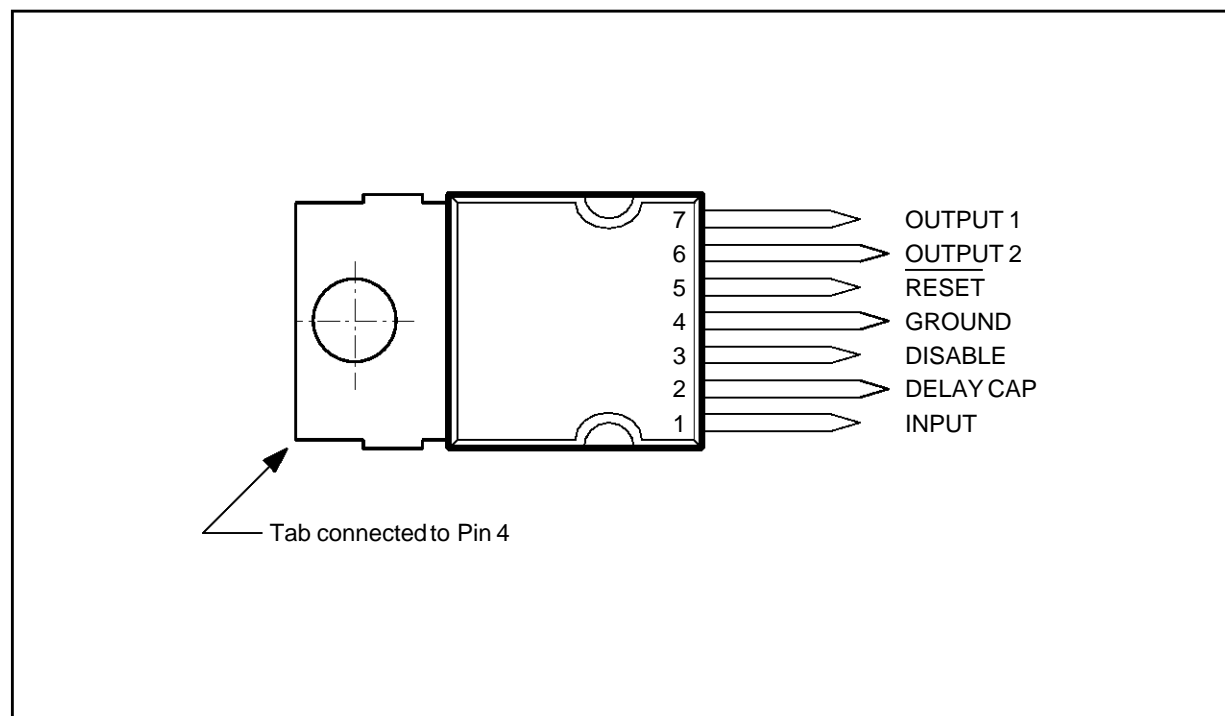

8137-01.EPS

# TDA8137

## BLOCK DIAGRAM

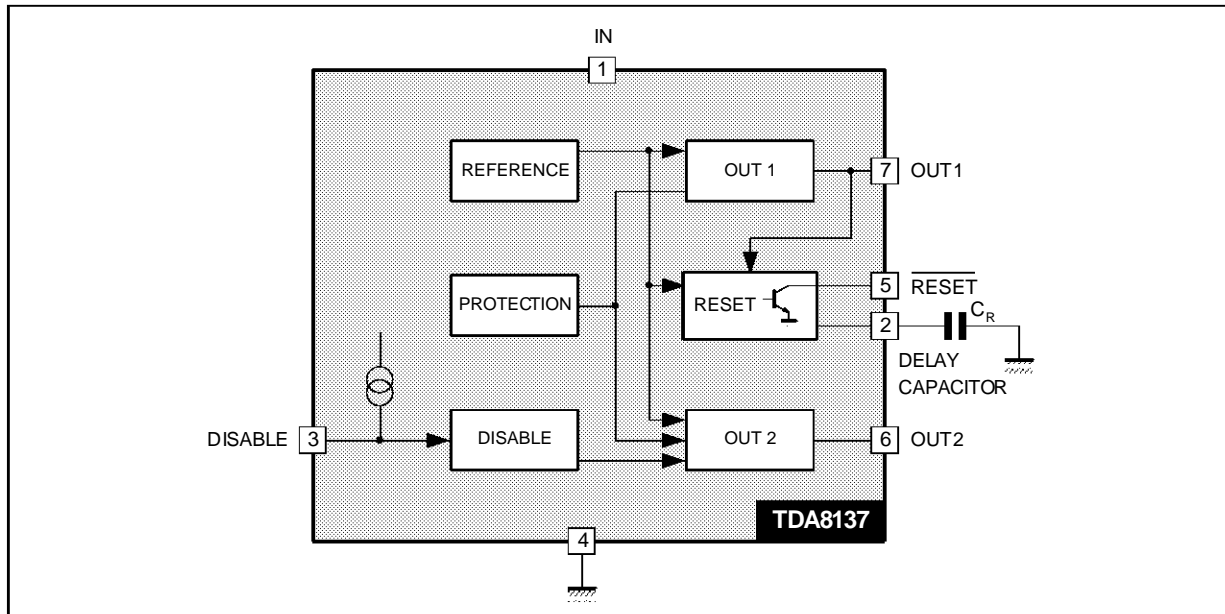

8137-02.EPS

## ABSOLUTE MAXIMUM RATINGS

Symbol	Parameter	Value	Unit
$V_{IN}$	DC Input Voltage Pin 1	20	V
$V_{DIS}$	Disable Input Voltage Pin 3	20	V
$V_{RST}$	Output Voltage at Pin 5	20	V
$I_{O1, 2}$	Output Currents	Internally Limited	
$P_t$	Power Dissipation	Internally Limited	
$T_{STG}$	Storage Temperature	- 65 to + 150	°C
$T_j$	Junction Temperature	0 to + 150	°C

8137-04.TBL

## THERMAL DATA

Symbol	Parameter	Value	Unit
$R_{TH(j-c)}$	Thermal Resistance Junction-case	Max. 3	°C/W
$T_j$	Recommended Junction Temperature	Max. 0 to + 150	°C

8137-02.TBL

## ELECTRICAL CHARACTERISTICS ( $V_{IN} = 7V$ ; $T_j = 25^\circ C$ unless otherwise specified)

Symbol	Parameter	Test Conditions	Min.	Typ.	Max.	Unit
$V_{O1, 2}$	Output Voltage	$I_{O1, 2} = 10mA$	5	5.1	5.2	V
		$7V < V_{IN} < 14V, 5mA < I_O < 750mA$	4.9		5.3	V
$V_{I O1, 2}$	Dropout Voltage	$I_{O1, 2} = 750mA$			1.4	V
		$I_{O1, 2} = 1A$			2	V
$\Delta V_{O1, 2LI}$	Line Regulation	$7V < V_{IN} < 14V, I_{O1, 2} = 200mA$			50	mV
$\Delta V_{O1, 2LO}$	Load Regulation	$5mA < I_{O1, 2} < 0.6A$			100	mV
$I_Q$	Quiescent Current	$I_{O1} = 10mA, \text{Output 2 Disabled}$			2	mA
$V_{O1RST}$	Reset Threshold Voltage	$(K = V_{O1})$	K-0.4	K-.25	K-0.1	V
$V_{RTH}$	Reset Threshold Hysteresis	(see circuit description)	20	50	75	mV
$t_{RD}$	Reset Pulse Delay at Pin 5	$C_e = 100nF$ (see circuit description)		25		ms
$V_{RL}$	Saturation Volt. at Pin 5 in Reset Condition	$I_5 = 5mA$			0.4	V

8137-03.TBL

**ELECTRICAL CHARACTERISTICS** ( $V_{IN} = 7V$  ;  $T_j = 25^\circ C$  unless otherwise specified) (continued)

Symbol	Parameter	Test Conditions	Min.	Typ.	Max.	Unit
$I_{RH}$	Leakage Current at Pin 5 in Normal Condition	$V_5 = 10V$			10	$\mu A$
$K_{0,2}$	Output Volt. Thermal Drift	$K_0 = \frac{\Delta V_o \cdot 10^6}{\Delta T \cdot V_o}$ $T_j = 0 \text{ to } +125^\circ C$		100		ppm/ $^\circ C$
$I_{01,2SC}$	Short Circ. Output Current	$V_{IN} = 7V$			1.6	A
		$V_{IN} = 16V$ , (see note 1)			1	A
$V_{DISH}$	Disable Volt. at Pin 3 High (out 2 active)		2			V
$V_{DISL}$	Disable Volt. at Pin 3 Low (out 2 disabled)				0.8	V
$I_{DIS}$	Disable Bias Current at Pin 3	$0V < V_{DIS} < 7V$	-100		2	$\mu A$
$T_{jSD}$	Junction Temp. for Thermal Shut Down			145		$^\circ C$

**Note 1:** The output short circuit currents are tested one channel at time. During a short circuit a large consumption of power occurs, anyway the thermal protection circuit guarantees the temperature not overcomes high value. Safe permanent short-circuit is only guaranteed for input voltages up to 16V.

**Figure 1**

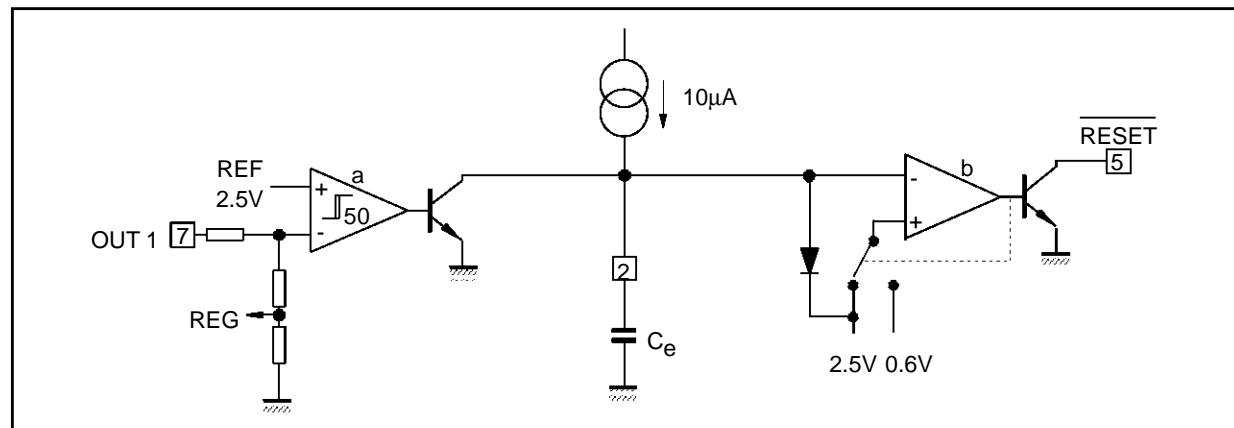

**Figure 2**

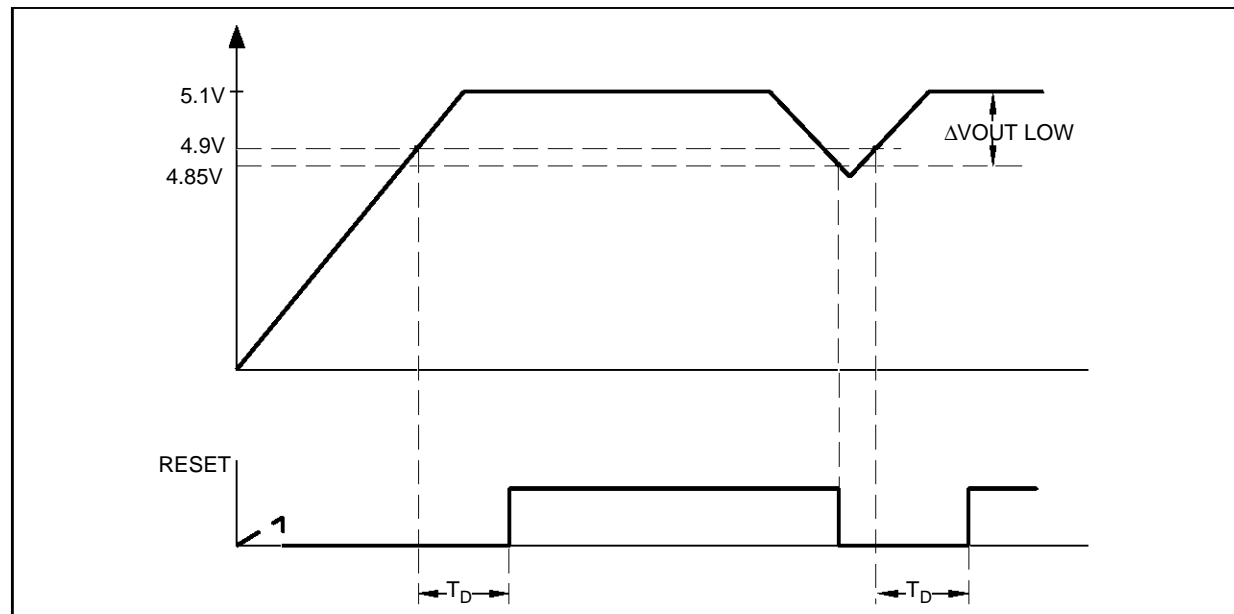

## TDA8137

### CIRCUIT DESCRIPTION

The TDA8137 is a dual voltage regulator with Reset and Disable.

The two regulation parts are supplied from one voltage reference circuit trimmed by zener zap during EWS test. Since the supply voltage of this last is connected at Pin 1 ( $V_{IN1}$ ), the regulator 2 will not work if the Pin 1 is not supplied.

The outputs stages have been realized in darlington configuration with a drop typical of 1.2V.

The disable circuit, switches off the output 2 if a voltage lower than 0.8V is applied at pin 3.

The Reset circuit checks the voltage at the output 1. If this one goes below  $V_{OUT} - 0.25V$  (4.85V Typ.), the comparator "a" (see Figure 1) discharges rapidly the capacitor  $C_e$  and the reset output goes at once low. When the voltage at the OUT 1 rises above  $V_{OUT} - 0.2V$  (4.9V Typ.), the voltage  $V_{C_e}$  increases linearly to 2.5V corresponding to a delay  $t_d$  following the low :  $t_d = \frac{C_e \cdot 2.5V}{10\mu A}$  (see figure 2), then the reset output goes high again. To avoid glitches in the reset output, the second comparator "b" has a large hysteresis (1.9V).

### TYPICAL APPLICATION

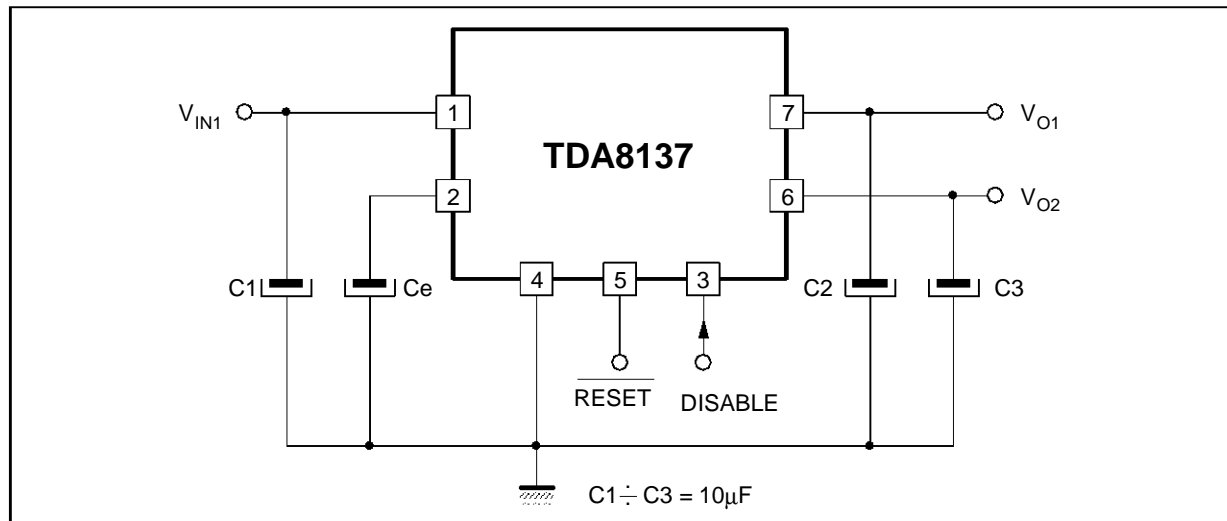

8137-05.EPS

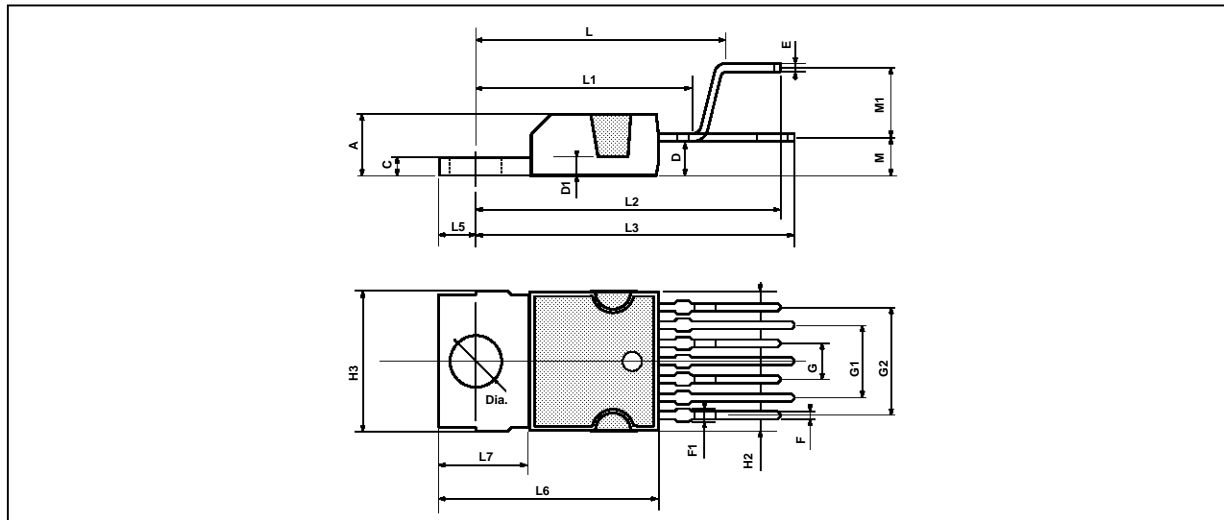
**PACKAGE MECHANICAL DATA**  
 9 PINS - PLASTIC HEPTAWATT

PM-HEPTV.EPS

Dimensions	Millimeters			Inches		
	Min.	Typ.	Max.	Min.	Typ.	Max.
A			4.8			0.189
C			1.37			0.054
D	2.4		2.8	0.094		0.110
D1	1.2		1.35	0.047		0.053
E	0.35		0.55	0.014		0.022
F	0.6		0.8	0.024		0.031
F1			0.9			0.035
G	2.41	2.54	2.67	0.095	0.100	0.105
G1	4.91	5.08	5.21	0.193	0.200	0.205
G2	7.49	7.62	7.8	0.295	0.300	0.307
H2			10.4			0.409
H3	10.05		10.4	0.396		0.409
L		16.97			0.668	
L1		14.92			0.587	
L2		21.54			0.848	
L3		22.62			0.891	
L5	2.6		3	0.102		0.118
L6	15.1		15.8	0.594		0.622
L7	6		6.6	0.236		0.260
M		2.8			0.110	
M1		5.08			0.200	
Dia.	3.65		3.85	0.144		0.152

HEPTV.TBL

Information furnished is believed to be accurate and reliable. However, SGS-THOMSON Microelectronics assumes no responsibility for the consequences of use of such information nor for any infringement of patents or other rights of third parties which may result from its use. No licence is granted by implication or otherwise under any patent or patent rights of SGS-THOMSON Microelectronics. Specifications mentioned in this publication are subject to change without notice. This publication supersedes and replaces all information previously supplied. SGS-THOMSON Microelectronics products are not authorized for use as critical components in life support devices or systems without express written approval of SGS-THOMSON Microelectronics.

© 1994 SGS-THOMSON Microelectronics - All Rights Reserved

Purchase of I<sup>2</sup>C Components of SGS-THOMSON Microelectronics, conveys a license under the Philips I<sup>2</sup>C Patent. Rights to use these components in a I<sup>2</sup>C system, is granted provided that the system conforms to the I<sup>2</sup>C Standard Specifications as defined by Philips.

SGS-THOMSON Microelectronics GROUP OF COMPANIES

Australia - Brazil - China - France - Germany - Hong Kong - Italy - Japan - Korea - Malaysia - Malta - Morocco  
 The Netherlands - Singapore - Spain - Sweden - Switzerland - Taiwan - Thailand - United Kingdom - U.S.A.