



# TDA8160

## ABSOLUTE MAXIMUM RATINGS

Symbol	Parameter	Value	Unit
$V_s$	Supply Voltage	16	V
$T_{stg-j}$	Storage and Junction Temperature	- 40, +150	°C
$P_{tot}$	Total Power Dissipation at $T_{amb} = 70\text{ °C}$	400	mW

8160-01.TBL

## THERMAL DATA

Symbol	Parameter	Value	Unit
$R_{th(j-a)}$	Thermal Resistance Junction-ambient	Max 200	°C/W

8160-02.TBL

## ELECTRICAL CHARACTERISTICS

(Refer to the test circuit ;  $V_s = 5V$ ,  $f_o = 10kHz$ ,  $T_{amb} = 25\text{ °C}$ , unless otherwise specified)

Symbol	Parameter	Test Conditions	Min.	Typ.	Max.	Unit
$V_s$	Supply Voltage	Applied between Pins 3 and 6	4	5	5.25	V
$I_s$	Supply Current (Pin 3)			6		mA
$V_3$	Stabilized Voltage at Pin 3	$I_3 = 8mA$		5.5		V
$G_v$ 1st	Voltage Gain (1st stage)			28		dB
$g_m$ 2nd	Transconductance (2nd stage)			15		mA/V
$V_{IN}$	Input Voltage Sensitivity (Pin 5)	For Full Swing at the Output Pin 1 $R_{gen} = 600\Omega$		2		mV <sub>P</sub>
$I_{IN}$	Input Current Sensitivity (Pin 5)	For Full Swing at the Output Pin 1		10		nA <sub>P</sub>
$R_{IN}$	Input Impedance			200		kΩ
$L_fR$	Low Frequency Rejection at the Input Stage	$C1 = 100pF$ , $f = 100HZ$			30	dB
$N$	Noise Signal at Pin 7	$C4$ Missing			200	mV <sub>PP</sub>

8160-03.TBL

**CIRCUIT DESCRIPTION** (see the block diagram)  
The infrared light received from D1 generates an AC signal that comes in to the device at pin 5. The capacitor C1 and the integrated 10kΩ resistor (pin 4) filter out the low frequency noise.

The first stage shows a voltage gain of about 28dB ; the second stage is a voltage to current converter of 50mA/V ( $R_2 = \text{Zero}$ ). A sensitive peak detector detects the amplifier signal ; one open collector output (pin 1) gives out the recovered pulses.

## TEST CIRCUIT

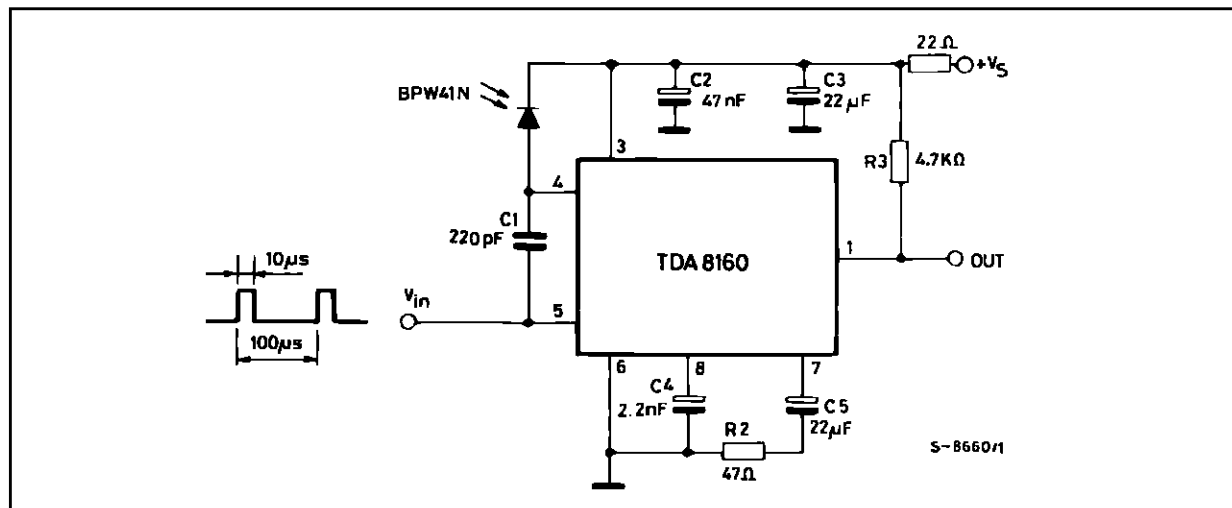

8160-03.EPS



**PACKAGE MECHANICAL DATA**

**8 PINS - PLASTIC DIP**

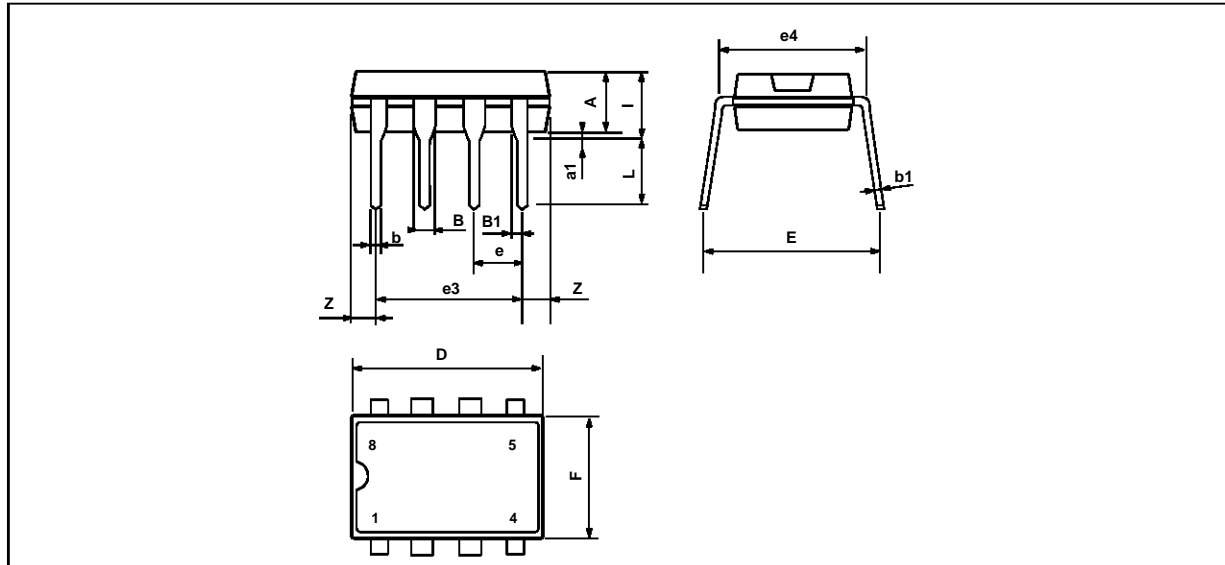

PM-DIP8.EPS

Dimensions	Millimeters			Inches		
	Min.	Typ.	Max.	Min.	Typ.	Max.
A		3.32			0.131	
a1	0.51			0.020		
B	1.15		1.65	0.045		0.065
b	0.356		0.55	0.014		0.022
b1	0.204		0.304	0.008		0.012
D			10.92			0.430
E	7.95		9.75	0.313		0.384
e		2.54			0.100	
e3		7.62			0.300	
e4		7.62			0.300	
F			6.6			0.260
i			5.08			0.200
L	3.18		3.81	0.125		0.150
Z			1.52			0.060

DIP8.TEL

Information furnished is believed to be accurate and reliable. However, SGS-THOMSON Microelectronics assumes no responsibility for the consequences of use of such information nor for any infringement of patents or other rights of third parties which may result from its use. No licence is granted by implication or otherwise under any patent or patent rights of SGS-THOMSON Microelectronics. Specifications mentioned in this publication are subject to change without notice. This publication supersedes and replaces all information previously supplied. SGS-THOMSON Microelectronics products are not authorized for use as critical components in life support devices or systems without express written approval of SGS-THOMSON Microelectronics.

© 1994 SGS-THOMSON Microelectronics - All Rights Reserved

Purchase of I<sup>2</sup>C Components of SGS-THOMSON Microelectronics, conveys a license under the Philips I<sup>2</sup>C Patent. Rights to use these components in a I<sup>2</sup>C system, is granted provided that the system conforms to the I<sup>2</sup>C Standard Specifications as defined by Philips.

**SGS-THOMSON Microelectronics GROUP OF COMPANIES**

Australia - Brazil - China - France - Germany - Hong Kong - Italy - Japan - Korea - Malaysia - Malta - Morocco  
The Netherlands - Singapore - Spain - Sweden - Switzerland - Taiwan - Thailand - United Kingdom - U.S.A.