

MULTISTANDARD AM AND FM SOUND IF CIRCUIT FOR TV

- A 2-STAGE GAIN CONTROLLED AMPLIFIER, PROVIDING COMPLETE IF GAIN ; (AM SECTION)
- A PEAK DETECTOR AND INTEGRATION WHICH PROVIDES AGC-VOLTAGE ; (AM SECTION)
- A 6-STAGE LIMITING AMPLIFIER FOLLOWED BY A SYNCHRONOUS DEMODULATOR AND DEEMPHASIS NETWORK ; (FM SECTION)
- AN AUDIO PREAMPLIFIER
- A CIRCUIT PROVIDING AM/FM SWITCHING AND MUTE FACILITIES
- AN EXTERNAL AUDIO INPUT CIRCUIT WITH SWITCHING FACILITIES TO DELIVER EITHER THE DEMODULATED IF, OR THE EXTERNAL AUDIO SIGNAL AT THE OUTPUT FULLY COMPATIBLE WITH THE SCART EUROPEAN NORM EN50 049
- A DC CONTROLLED VOLUME CIRCUIT

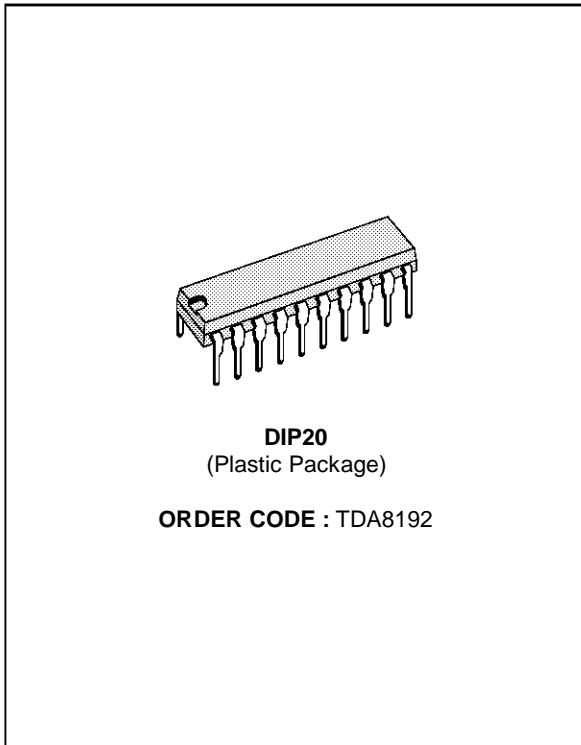

DESCRIPTION

The demodulated IF signal is always available at a low impedance output.

PIN CONNECTIONS

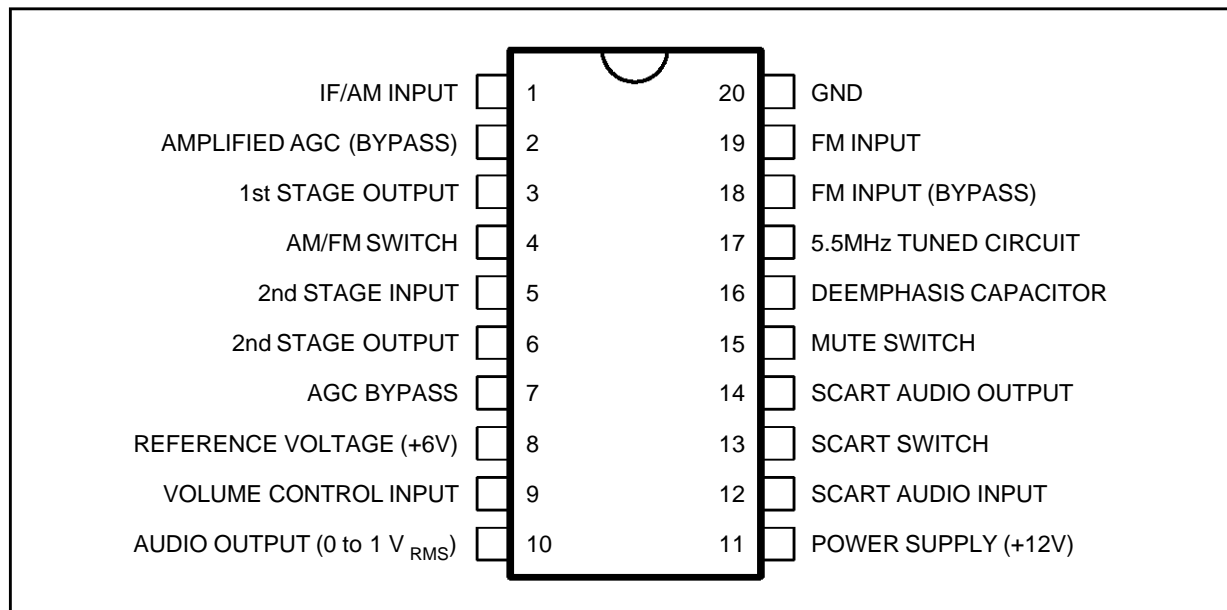

8192-01.EPS

TDA8192

BLOCK DIAGRAM

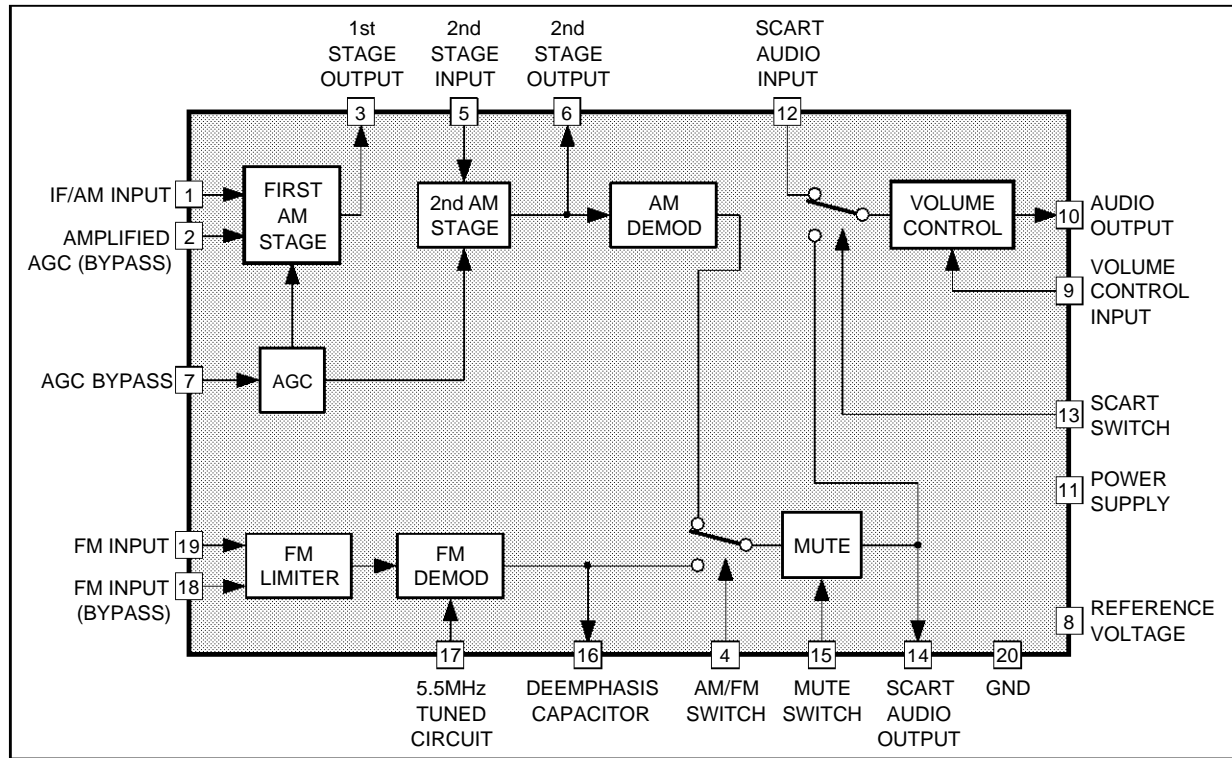

ABSOLUTE MAXIMUM RATINGS

Symbol	Parameter	Value	Unit
V_S	Supply Voltage	16	V
P_{tot}	Total Power Dissipation at $T_{amb} \leq 70^\circ\text{C}$	800	mW
T_{op}	Operating Temperature	0 to 70	$^\circ\text{C}$
T_{stg}, T_j	Storage and Junction Temperature	-55 to 150	$^\circ\text{C}$

THERMAL DATA

Symbol	Parameter	Value	Unit
$R_{th\ j-amb}$	Thermal Resistance Junction-ambient	Max. 100	$^\circ\text{C}/\text{W}$

ELECTRICAL CHARACTERISTICS ($T_{amb} = 25^{\circ}\text{C}$, $V_S = 12\text{V}$ unless otherwise specified)

Symbol	Parameter	Test Conditions	Min.	Typ.	Max.	Unit
V_S	Supply Voltage		10.8	12	13.2	V
I_d	Supply Current	$V_i = 0$ AM FM		30 30		mA mA

AM SECTION ($f_i = 39.2\text{MHz}$, $V_i = 1\text{mV}$, $m = 0.8$, $f_m = 1\text{kHz}$ unless otherwise specified)

V_i	Input Sensitivity	S/N = 26dB		35		μV
$\frac{S+N}{N}$	Signal to Noise Ratio	$V_i = 0.1\text{mV}$ $m = 0.3$ $V_i = 1\text{mV}$ $V_i = 10\text{mV}$	50	36 50 56		dB
V_i	AGC Range	$\Delta V_{OUT} = -1$ to $+1\text{dB}$		66		dB
V_o	Recovered Audio Signal		0.6	1	1.5	V_{RMS}
d	Distortion (1)				3	%
d	Distortion (2)				3	%
R_i	Input Resistance between Pins 1 and 2	$m = 0$	2			$\text{k}\Omega$
C_i	Input Capacitance between Pins 1 and 2	$m = 0$		18		pF

FM SECTION ($f_i = 5.5\text{MHz}$, $V_i = 1\text{mV}$, $\Delta f = \pm 50\text{kHz}$, $f_m = 1\text{kHz}$, unless otherwise specified) (continued)

V_i	Input Limiting Voltage	-3dB Limiting Point		30		μV
AMR	Amplitude Modulation	$V_i = 30\text{mV}$, $m = 0.3$		55		dB
$\frac{S+N}{N}$	Signal to Noise Ratio	$V_i = 1\text{mV}$	60			dB
d	Distortion (3)				1.5	%
d	Distortion (4)			2		%
V_o	Recovered Audio Signal		0.5	1	1.5	V_{RMS}
R_i	Input Resistance	$\Delta f = 0$	2			$\text{k}\Omega$
C_i	Input Capacitance	$\Delta f = 0$		14		pF
C_T	Crosstalk AM/FM			70		dB

AM/FM AND MUTE SWITCHING

	FM "on" (pin. 4)		2.5		V_S	V
	AM "on" (pin 4)		0		0.8	V
	Mute "on" (pin 15)		0		1	V
	Mute "off" (pin 15)		5		V_S	V
	Signal Attenuation for Mute "off"		70			dB
	Mute Switch Current				110	μA
	AM/FM Switch Current		50		250	μA

SCART SWITCHING

	Mode Selection Voltage : TV Selected (pin. 13)		0		5	V
	Mode Selection Voltage : Scart Selected (pin 13)		8		12	V
	Scart Switch Input Resistance		10			$\text{k}\Omega$
	Scart Audio Input Amplitude (pin 12)			0.5	2	V_{rms}
	Crosstalk Between Switched Inputs (TV scart)			80		dB

DC VOLUME CONTROL

	Audio Output Impedance (pin 10)				1	$\text{k}\Omega$
	Control Range			90		dB
	Output/input Gain for Maximum Gain Control			0		dB
	Gain Control Voltage		0.5		4.5	V
	Noise Level (DIN 45405)			25		μV_{rms}

- (1) 50% volume setting, $V_i = 1\text{mV}$
(2) 50% volume setting, $V_i = 10\text{mV}$
(3) $V_i = 1\text{mV}$, $f_m = 100$ to 10.000Hz
(4) $V_i = 1\text{mV}$, $\pm 20\text{kHz}$ offset (detuning of phase shift filter).

TEST CIRCUIT

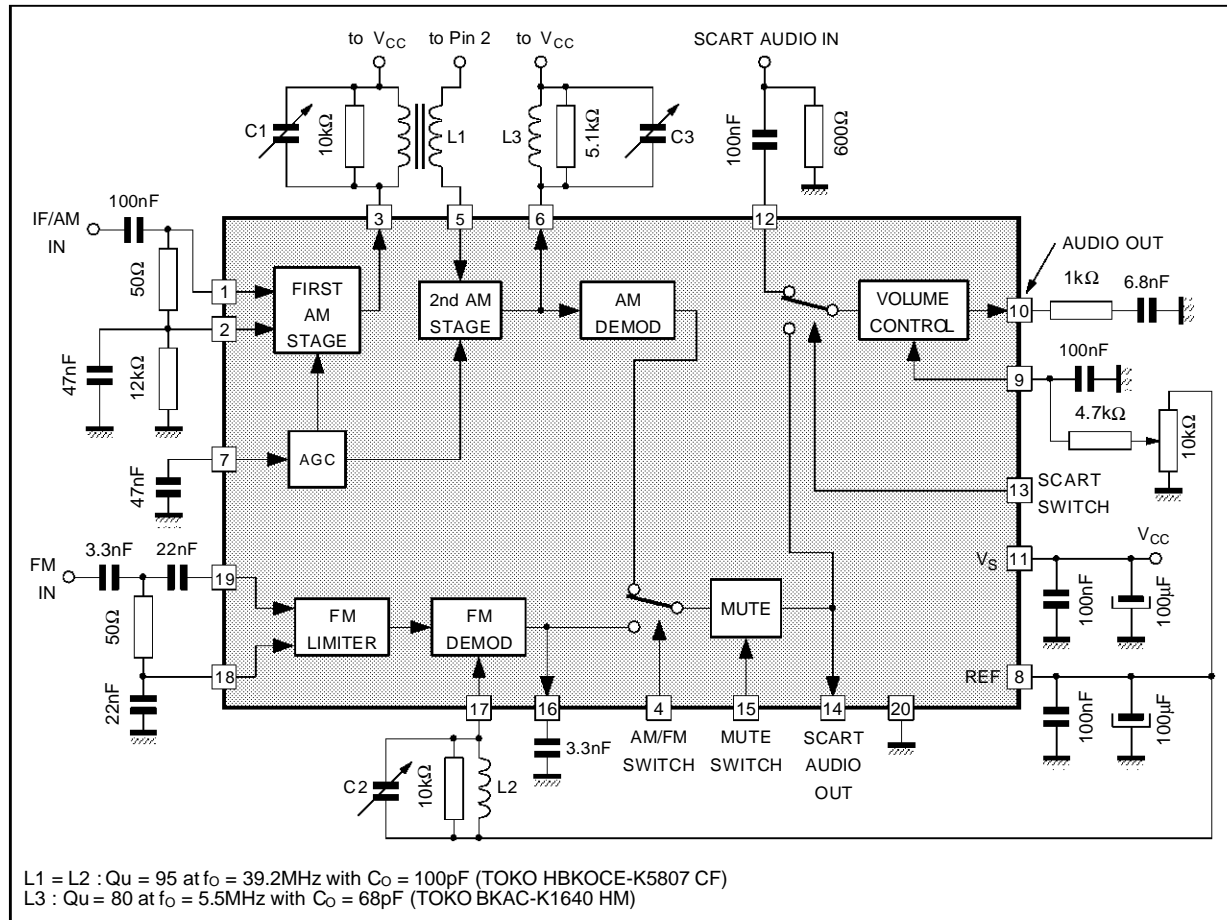

8192-03.EPS

PACKAGE MECHANICAL DATA
20 PINS - PLASTIC DIP

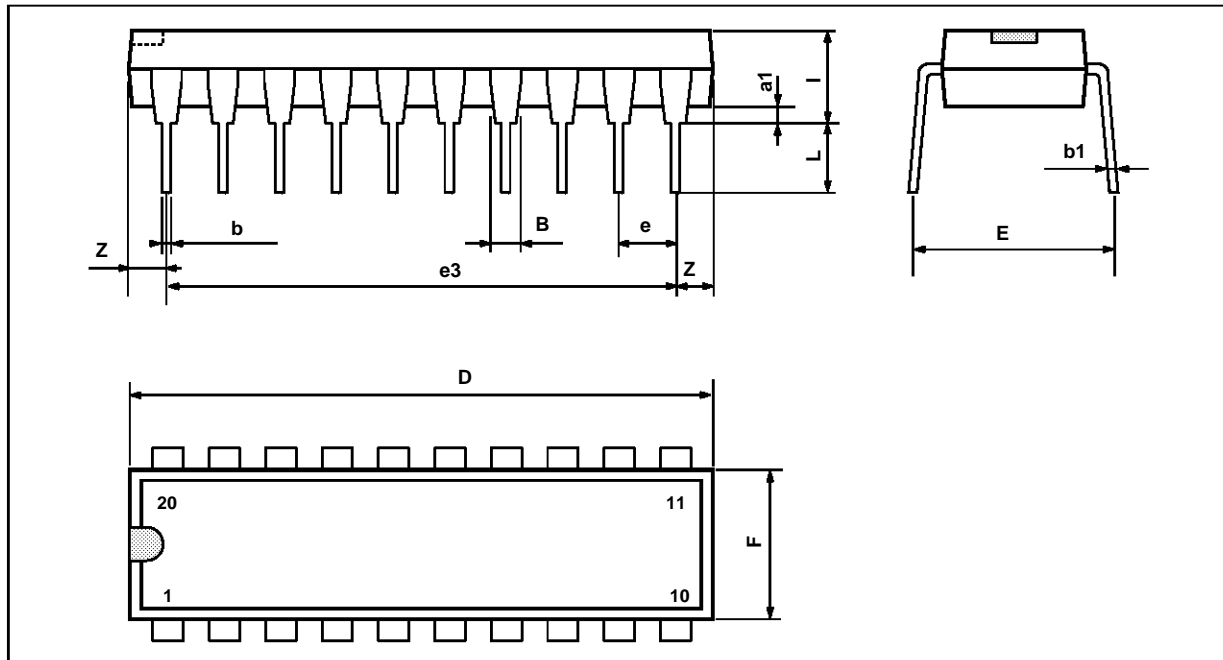

PM-DIP20.EPS

Dimensions	Millimeters			Inches		
	Min.	Typ.	Max.	Min.	Typ.	Max.
a1	0.254			0.010		
B	1.39		1.65	0.055		0.065
b		0.45			0.018	
b1		0.25			0.010	
D			25.4			1.000
E		8.5			0.335	
e		2.54			0.100	
e3		22.86			0.900	
F			7.1			0.280
i			3.93			0.155
L		3.3			0.130	
Z			1.34			0.053

DIP20.TBL

Information furnished is believed to be accurate and reliable. However, SGS-THOMSON Microelectronics assumes no responsibility for the consequences of use of such information nor for any infringement of patents or other rights of third parties which may result from its use. No licence is granted by implication or otherwise under any patent or patent rights of SGS-THOMSON Microelectronics. Specifications mentioned in this publication are subject to change without notice. This publication supersedes and replaces all information previously supplied. SGS-THOMSON Microelectronics products are not authorized for use as critical components in life support devices or systems without express written approval of SGS-THOMSON Microelectronics.

© 1994 SGS-THOMSON Microelectronics - All Rights Reserved

Purchase of I²C Components of SGS-THOMSON Microelectronics, conveys a license under the Philips I²C Patent. Rights to use these components in a I²C system, is granted provided that the system conforms to the I²C Standard Specifications as defined by Philips.

SGS-THOMSON Microelectronics GROUP OF COMPANIES

Australia - Brazil - China - France - Germany - Hong Kong - Italy - Japan - Korea - Malaysia - Malta - Morocco
The Netherlands - Singapore - Spain - Sweden - Switzerland - Taiwan - Thailand - United Kingdom - U.S.A.