

**DOUBLE AUDIO SWITCH
AND DC VOLUME CONTROL FOR TV**

- A DOUBLE TWO-INPUT CIRCUITS WITH SWITCHING FACILITIES
- A DOUBLE DC VOLUME CONTROL
- 12dB MAXIMUM GAIN
- 90dB SIGNAL DYNAMIC RANGE

DESCRIPTION

The TDA8198 is a monolithic integrated circuit in DIP14 package intended for TV applications which provides Audio switching facilities between two double inputs including DC volume control.

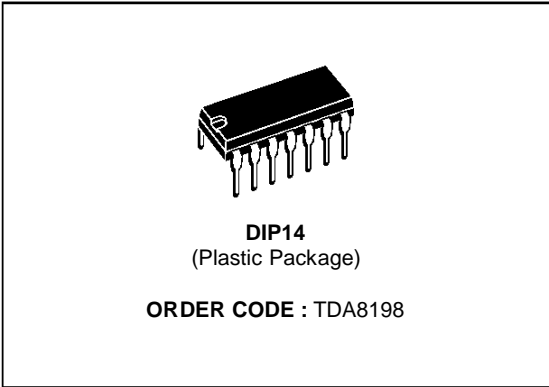

PIN CONNECTIONS

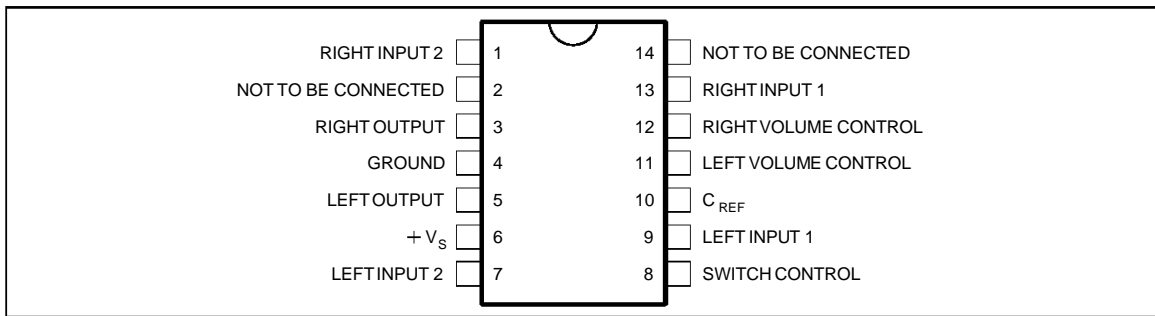

BLOCK DIAGRAM

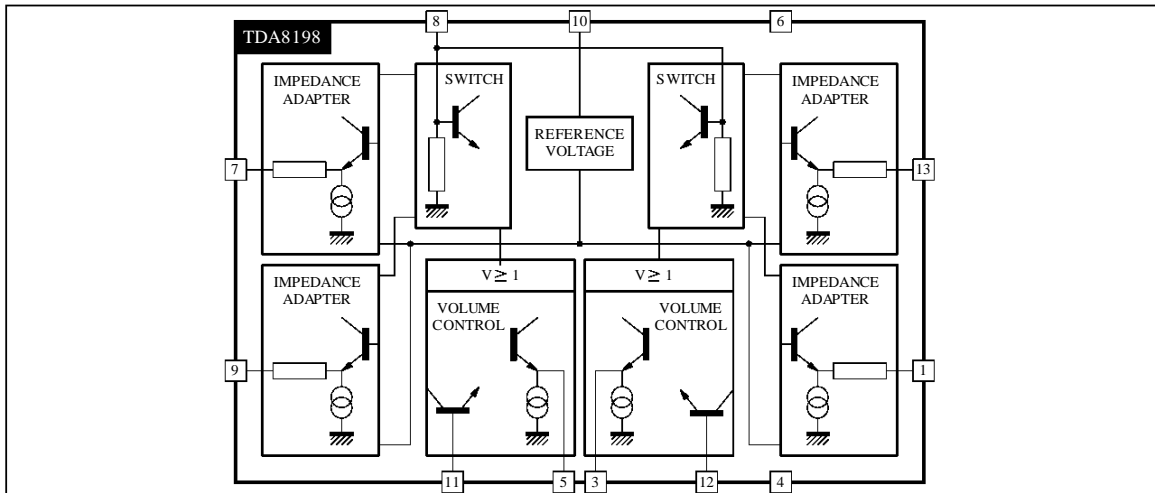

ABSOLUTE MAXIMUM RATINGS

Symbol	Parameter	Value	Unit
V_S	Supply Voltage	16	V
T_{stg}	Storage Temperature	-55, +125	°C
T_{oper}	Operating Ambient Temperature	0, +70	°C

8198-01.TBL

ELECTRICAL CHARACTERISTICS

Measured according to the following conditions, unless otherwise specified : $T_{amb} = 25^{\circ}\text{C}$, $V_S = +12\text{V}$.

Symbol	Parameter	Min.	Typ.	Max.	Unit
V_S	Supply Voltage Range	10.8	12	13.2	V
I_S	Supply Current ($V_{IN} = 0$, $V_C = 0.5\text{V}$)		24	32	mA
V_R	Reference Voltage		6.9		V
V_M	Mode Selection Voltage Audio 1 Audio 2	9.5		5 V_S	V
R_{SW}	Switching Input Resistance	15	30		k Ω
V_I	Audio Input Amplitude		0.125	0.3	V_{RMS}
Δk	DC Volume Control Range @ $V_I = 0.3V_{RMS}$	70	90		dB
k_{MIN}	Output/Input Gain for Maximum Volume ($V_C = 5\text{V}$)		12		dB
dK	Gain Difference between Channels at $V_C = 5\text{V}$		0		dB
V_C	Voltage Control Range $k = k_{MAX}$ (volume minimum) $k = k_{MIN}$ (volume maximum)	5		0.5	V
THD1	Distortion for $V_I = 0.25V_{RMS}$ at Maximum Volume		0.3	1	%
THD2	Distortion for $V_O = 1.2V_{RMS}$			5	%
C_T	Crosstalk between Switched Inputs		80		dB
C_C	Crosstalk between Channels 1 & 2		70		dB
R_I	Audio Input Resistance		22		k Ω
R_O	Audio Output Resistance		10	300	Ω
	Output Noise Level @ $V_C = 5\text{V}$ (weighted) (curve : DIN45 405)		300		μV_{RMS}
I - V_C	Volume Control Input Current (Pins 11 and 12) at $V_C = 5\text{V}$		-12		μA
	Volume thermal stability ($k = 30\text{dB}$, $0 < T_{amb} < 60^{\circ}\text{C}$)		0.04		dB/°C

8198-02.TBL

Figure 1 : Gain versus Volume Control

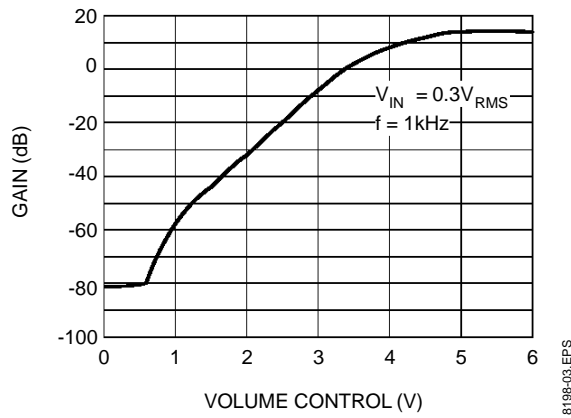

Figure 2 : Distortion versus Volume Control

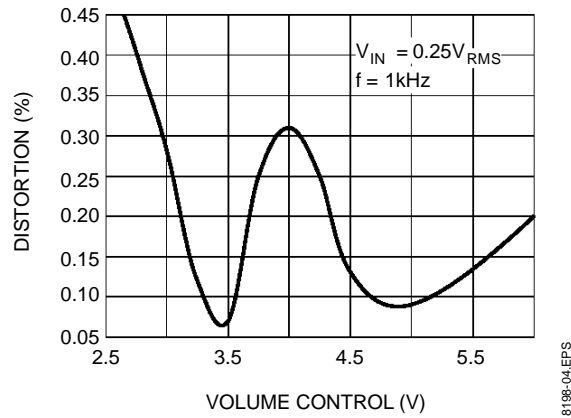

Figure 3 : Distortion versus Voltage Input

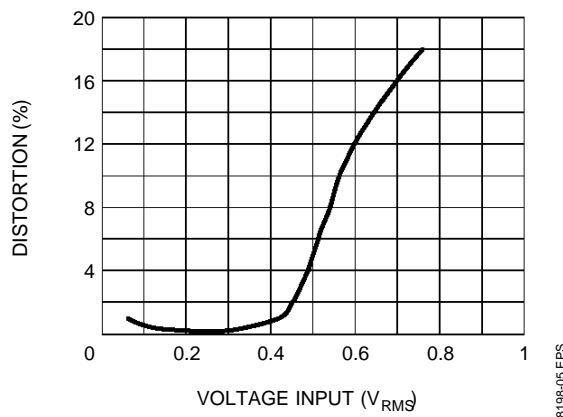

Figure 4 : Supply Voltage Rejection

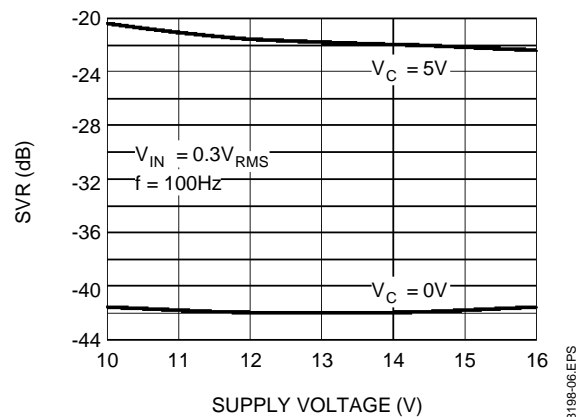

Figure 5 : Volume Control Current versus Voltage (pins 11 - 12)

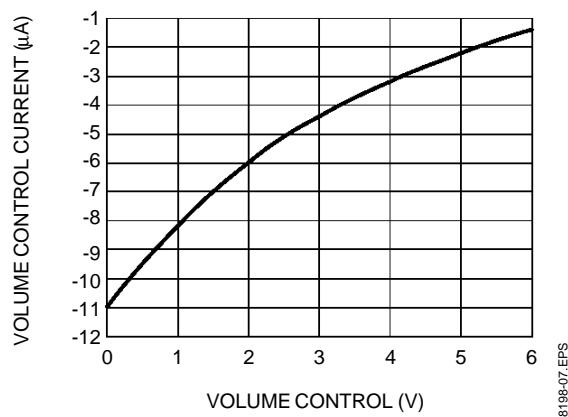
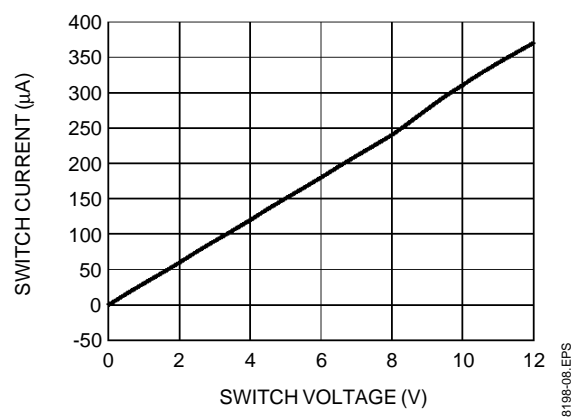
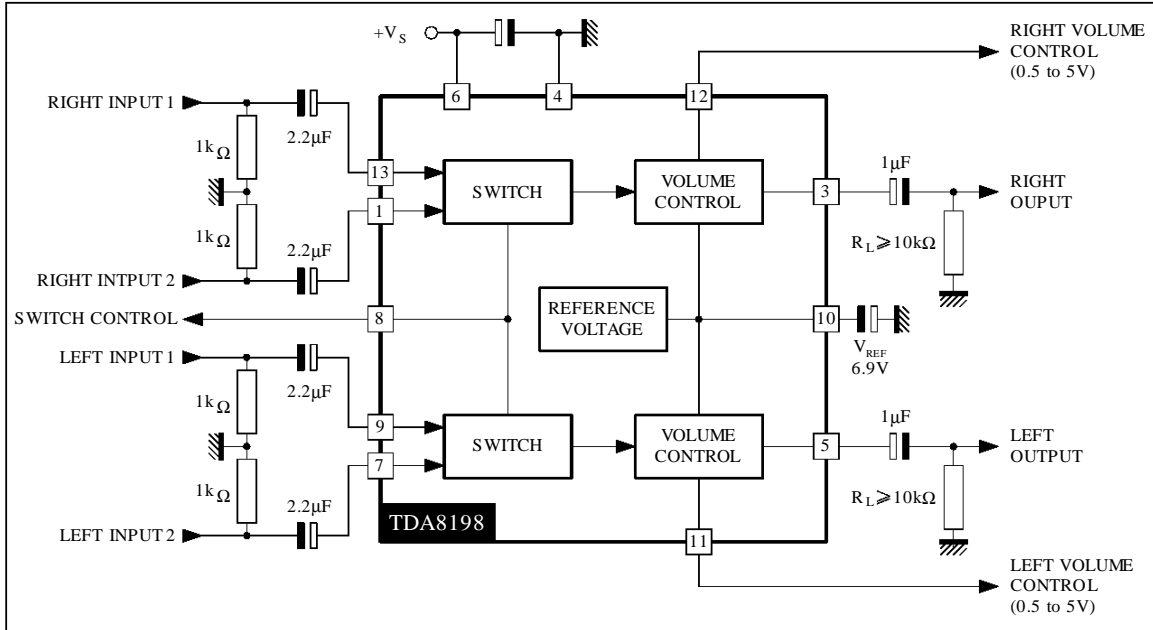

Figure 6 : Switch Current versus Voltage (pin 8)



APPLICATION DIAGRAM



8198-09.EPS

PACKAGE MECHANICAL DATA

14 PINS - PLASTIC DIP

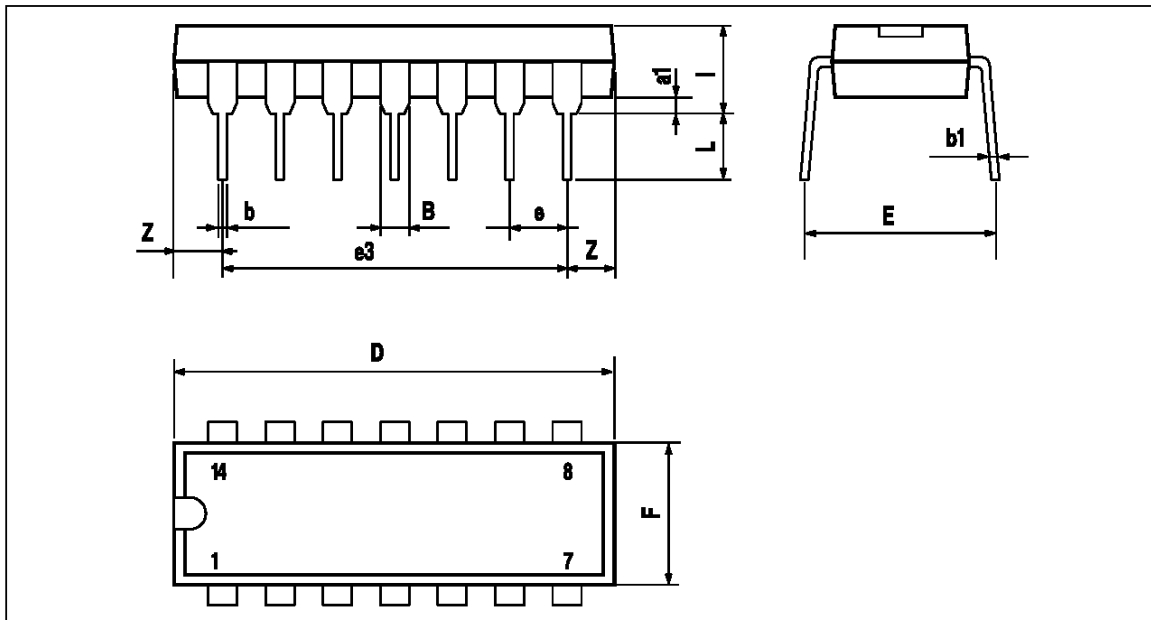

Dimensions	Millimeters			Inches		
	Min.	Typ.	Max.	Min.	Typ.	Max.
a1	0.51			0.020		
B	1.39		1.65	0.055		0.065
b		0.5			0.020	
b1		0.25			0.010	
D			20			0.787
E		8.5			0.335	
e		2.54			0.100	
e3		15.24			0.600	
F			7.1			0.280
l			5.1			0.201
L		3.3			0.130	
Z	1.27		2.54	0.050		0.100

Information furnished is believed to be accurate and reliable. However, SGS-THOMSON Microelectronics assumes no responsibility for the consequences of use of such information nor for any infringement of patents or other rights of third parties which may result from its use. No licence is granted by implication or otherwise under any patent or patent rights of SGS-THOMSON Microelectronics. Specifications mentioned in this publication are subject to change without notice. This publication supersedes and replaces all information previously supplied. SGS-THOMSON Microelectronics products are not authorized for use as critical components in life support devices or systems without express written approval of SGS-THOMSON Microelectronics.

© 1996 SGS-THOMSON Microelectronics - All Rights Reserved

Purchase of I^2C Components of SGS-THOMSON Microelectronics, conveys a license under the Philips I^2C Patent. Rights to use these components in a I^2C system, is granted provided that the system conforms to the I^2C Standard Specifications as defined by Philips.

SGS-THOMSON Microelectronics GROUP OF COMPANIES

Australia - Brazil - Canada - China - France - Germany - Hong Kong - Italy - Japan - Korea - Malaysia - Malta - Morocco
The Netherlands - Singapore - Spain - Sweden - Switzerland - Taiwan - Thailand - United Kingdom - U.S.A.