

PAL DECODER AND VIDEO PROCESSOR

- RGB OUTPUTS
- SINGLE CHIP CHROMA AND LUMINANCE PROCESSOR
- DC CONTROL BRIGHTNESS, CONTRAST, AND SATURATION
- FEW EXTERNAL COMPONENTS
- FAST BLANKING INPUT FOR OSD INSERTION
- SUPER SANDCASTLE INPUT

DESCRIPTION

The TDA8217 is a monolithic integrated color decoder for the PAL standard. It includes in a 20 pins IC all the functions required for the identification and demodulation of PAL signals, and all the video-processor functions up to the drive of the video stages. Used with TDA8213 (video & sound IF system) and TDA8214A (H/V deflection circuit), this IC permits a complete low-cost solution for PAL applications.



PIN CONNECTIONS

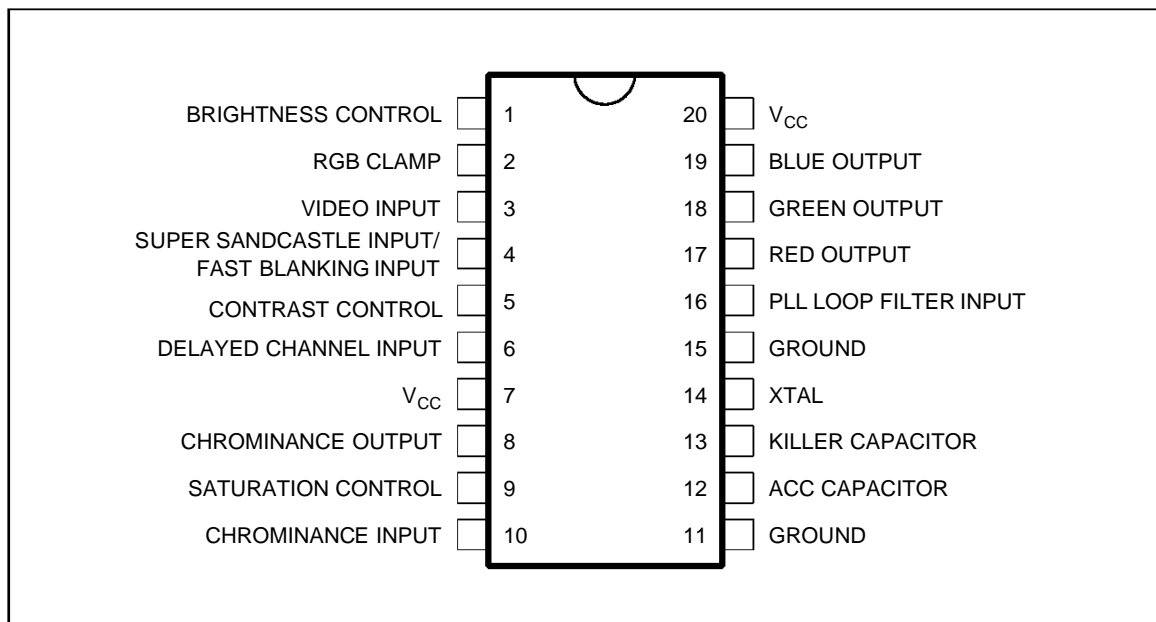

8217-01.EPS

TDA8217

BLOCK DIAGRAM

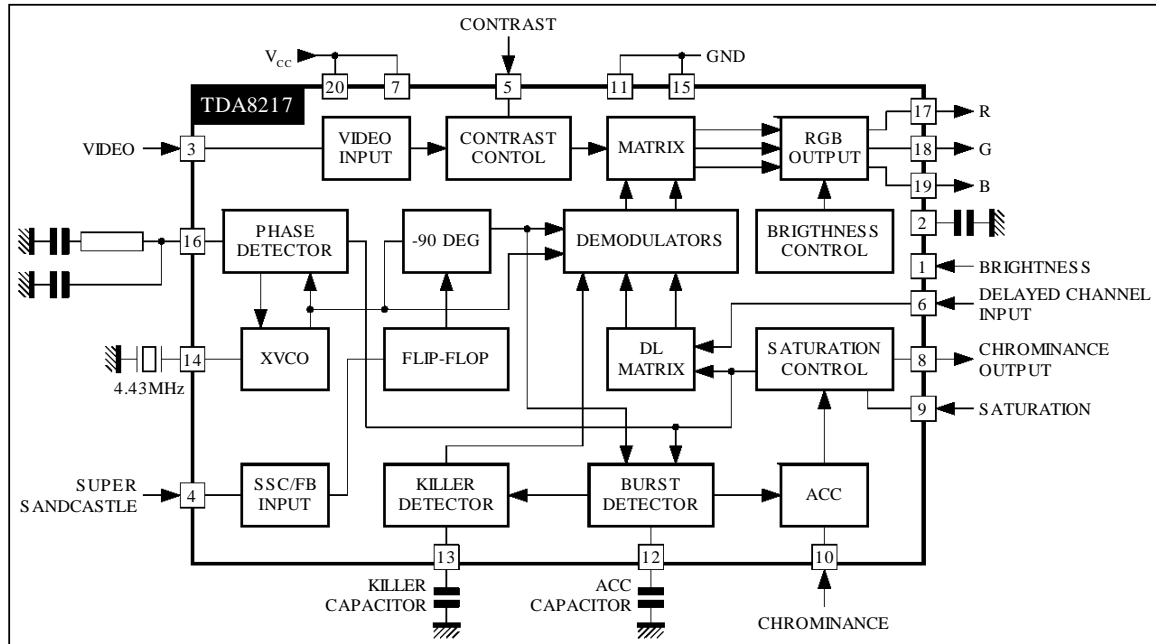

ABSOLUTE MAXIMUM RATINGS

Symbol	Parameter	Value	Unit
V_{CC}	Supply Voltage	12	V
T_{oper}	Operating Temperature	0 , + 70	°C
T_{stg}	Storage Temperature	-55 , + 150	°C

THERMAL DATA

Symbol	Parameter	Value	Unit
$R_{th(j-a)}$	Thermal Resistance Junction-Ambient	Max. 80	°C/W

DC AND AC ELECTRICAL CHARACTERISTICS

$V_{CC} = 9V$, $T_{AMB} = 25^{\circ}C$ (unless otherwise specified)

Symbol	Parameter	Test Conditions	Min.	Typ.	Max.	Unit
V_{CC}	Supply Voltage		8	9	10	V
I_{CC}	Supply Current	No Load		30	50	mA
P_D	Total Power Dissipation	No Load		270	450	mW

LUMINANCE INPUT (Pin 3)

	Input Level before Clipping (Black to White)				500	mV _{PP}
	DC Operating Voltage	No Input Signal	2.5	2.8	3.1	V
	Input Current	During Burst Period	± 50	± 100	± 150	µA
		Out of Burst Period			5	µA

CHROMINANCE INPUT (Pin 10)

	Input Level before Clipping				900	mV _{PP}
	ACC Control Range	Change of Burst Signal over whole ACC Control Range < 1dB	30			dB
	Minimum Burst Signal Amplitude within the ACC Control Range		30			mV _{PP}

DC AND AC ELECTRICAL CHARACTERISTICS (continued)V_{CC} = 9V , T_{AMB} = 25°C (unless otherwise specified)

Symbol	Parameter	Test Conditions	Min.	Typ.	Max.	Unit
CHROMINANCE INPUT (Pin 10) (continued)						
	Input Impedance		6	8	12	kΩ
	DC Operating Voltage	No Input Signal	2.3	2.8	3.3	V
SSC INPUT (Pin 4)						
	Burst Gate Threshold		7.0	7.5	8.0	V
	Line Blanking Threshold		3.1	3.6	3.9	V
	Frame Blanking Threshold / Fast Blanking		0.5	1	1.5	V
	Input Current				60	μA
CONTRAST CONTROL INPUT (Pin 5) (See Figure 1)						
	Input Current				10	μA
	Contrast Control Range		20			dB
SATURATION CONTROL INPUT (Pin 9) (See Figure 2)						
	Input Current				10	μA
	Tracking between Luminance and Chrominance Signals over 10 dB Contrast Control				2	dB
BRIGHTNESS CONTROL INPUT (Pin 1) (See Figure 3)						
	Input Current				10	μA
ACC CAPACITOR (Pin 12)						
	Charging Current	During Burst Gate Period		100		μA
	Discharging Current	During Burst Gate Period			10	μA
	Leakage Current	Out of Burst Gate Period			5	μA
KILLER CAPACITOR (Pin 13)						
	Color off Voltage	No Chroma Signal		5.6		V
	Color on Voltage			6		V
	PAL flip-flop inhibition level			3.2		V
	Control Current			150		μA
	Leakage Current				5	μA
	Voltage with Nominal Input Signal		6.4	6.5	7.0	V
PLL LOOP FILTER (Pin 16)						
	Control Current			800		μA
	Leakage Current				5	μA
SUBCARRIER OUTPUT (Pin 8)						
	Output Burst Amplitude	Within ACC Control Range	1.6	2.4	3.0	V _{PP}
DELAYED CHANNEL INPUT (Pin 6)						
	DC Operating Voltage	No Input Signal	2.0	2.2	2.4	V
	Input impedance		6	8	12	kΩ
RGB OUTPUTS (Pins 17-18-19)						
	Output Signal Amplitude (Black to White)	0.35V B to W, Signal @ Pin 3, Contrast @ 4.2V, Sat. @ 1.6V, Brig. @ 3.5V	2.80	3.15	3.50	V
	Blue Channel Output Amplitude (no Y)	300 mV _{PP} (B-Y), Signal with 200mV _{PP} Burst Amplitude at pin 10, Contrast @ 4.2V, Sat. @ 4.2V, Brig. @ 3.5V	3.5	3.9	4.3	V _{PP}
	Individual Output Sinking Current				2	mA

8217-04.TBL

DC AND AC ELECTRICAL CHARACTERISTICS (continued)

V_{CC} = 9V , T_{AMB} = 25°C (unless otherwise specified)

Symbol	Parameter	Test Conditions	Min.	Typ.	Max.	Unit
RGB OUTPUTS (Pins 17-18-19)						
	Maximum Peak White Level		7.4	7.8	8.2	V
	Blanking Level		1.0	1.2	1.4	V
	Black Level Differential Error				300	mV
	Relative Variation in Black Level with Various Saturation, Contrast and Brightness Control Level				10	mV
	Black Level Thermal Drift			0.5		mV/°C
	Differential Black Level Drift over 40°C Temperature Range			5		mV
	Frequency Response(-3dB)			5		MHz

XTAL (Pin 14)

	Catching Range		± 500	± 700		Hz
--	----------------	--	-------	-------	--	----

RGB CLAMP CAPACITOR (Pin 2)

	Control Current		50	100	150	µA
	Leakage Current				5	µA

8217-05.TBL

Figure 1 : Contrast Control Voltage Range

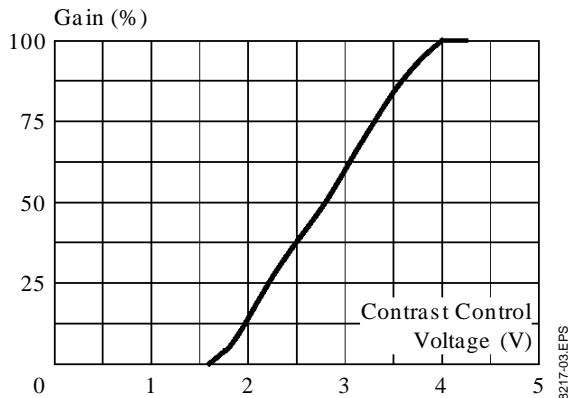

8217-03.EPS

Figure 2 : Saturation Control Voltage Range

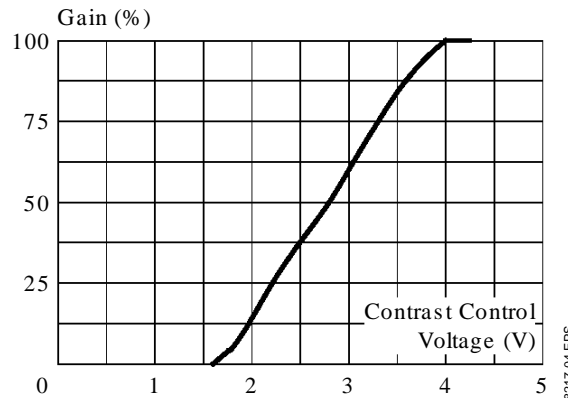

8217-04.EPS

Figure 3 : Brightness Control Voltage Range

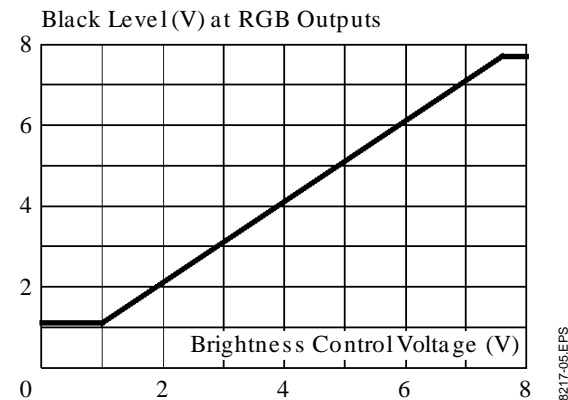

8217-05.EPS

INPUT / OUTPUT PIN CONFIGURATION

Figure 4 : Pins 1 - 2 Configuration

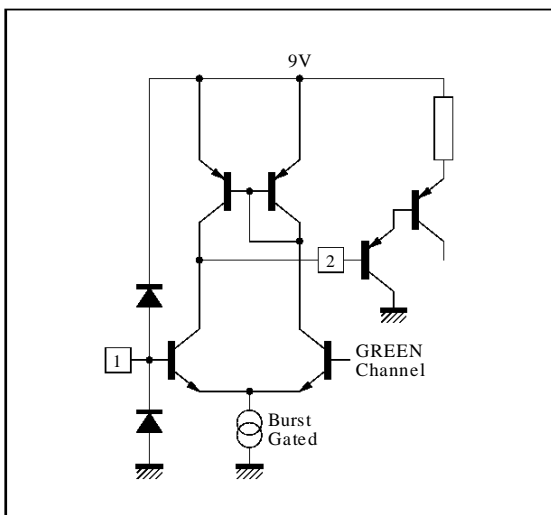

Figure 5 : Pin 3 Configuration

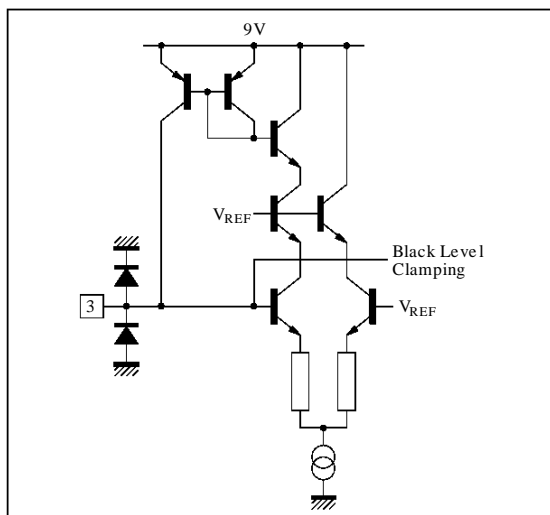

Figure 6 : Pin 4 Configuration

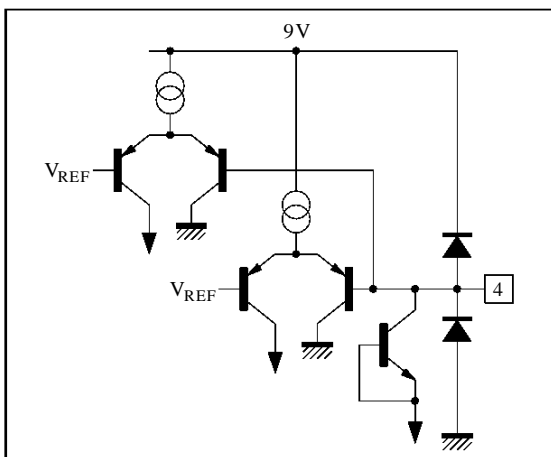
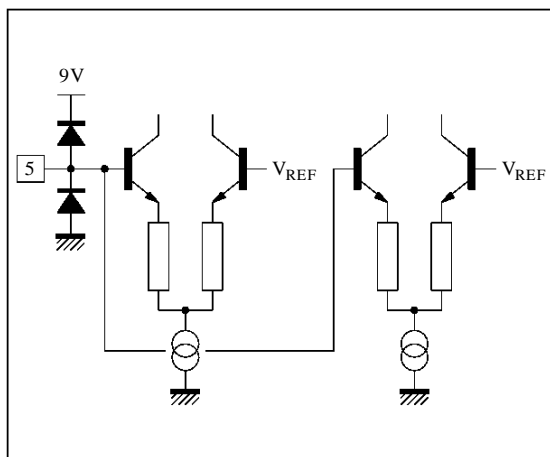
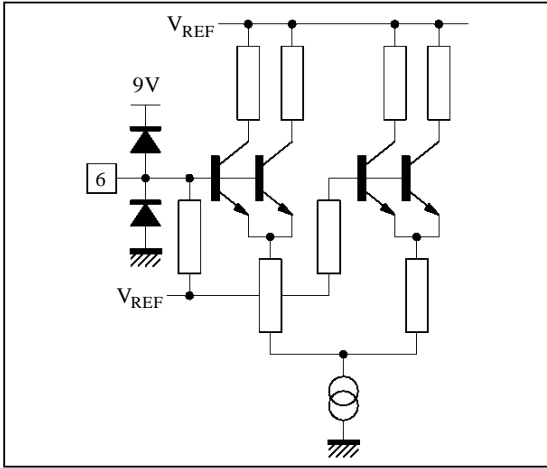

Figure 7 : Pin 5 Configuration



INPUT / OUTPUT PIN CONFIGURATION (continued)

Figure 8 : Pin 6 Configuration



8217-10.EPS

Figure 9 : Pin 8 Configuration

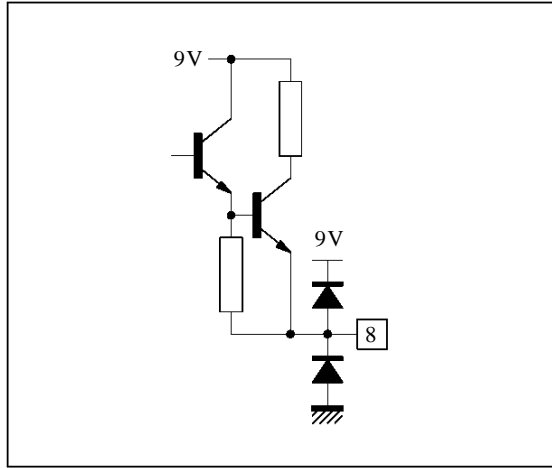

8217-11.EPS

Figure 10 : Pin 9 Configuration

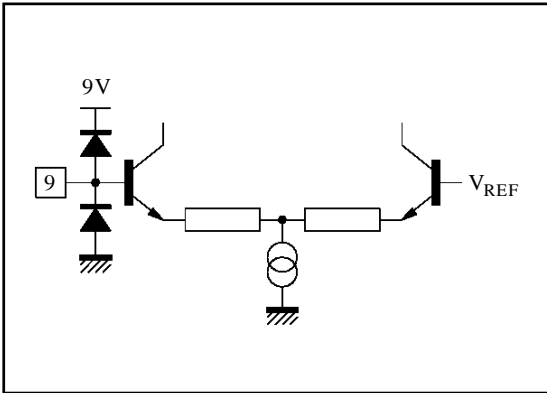

8217-12.EPS

Figure 11 : Pin 10 Configuration

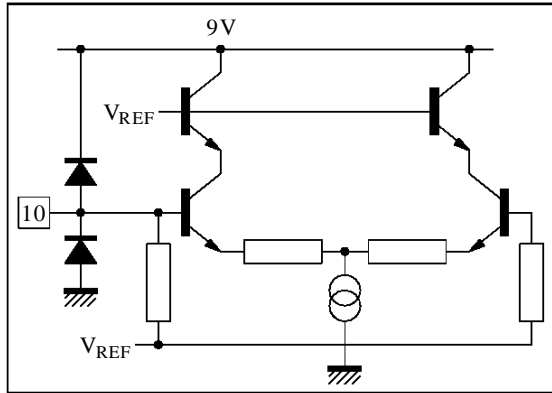

8217-13.EPS

Figure 12 : Pin 12 Configuration

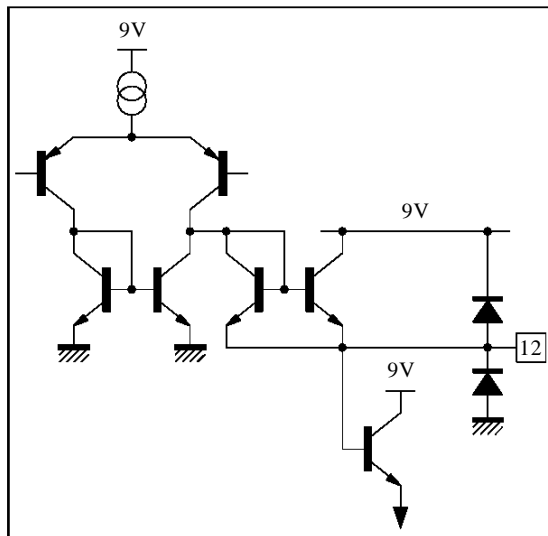

8217-14.EPS

INPUT / OUTPUT PIN CONFIGURATION (continued)

Figure 13 : Pin 13 Configuration

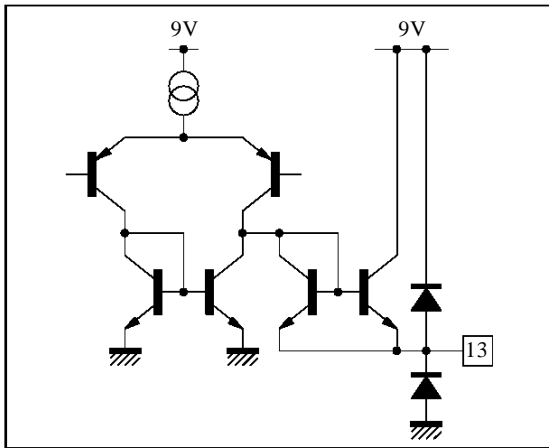

8217-15.EPS

Figure 14 : Pin 14 Configuration

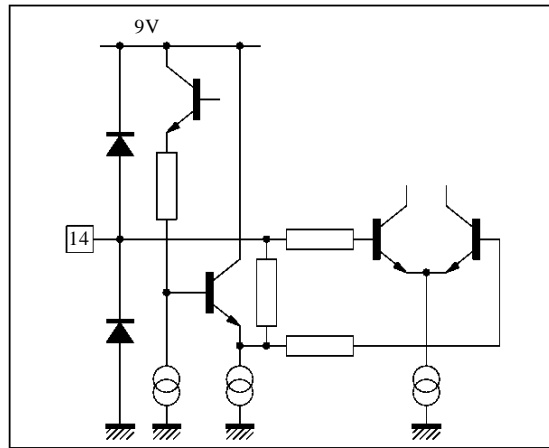

8217-16.EPS

Figure 15 : Pin 16 Configuration

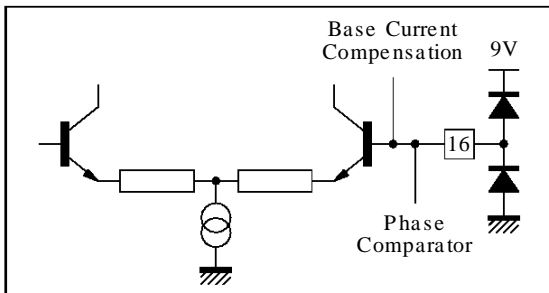

8217-17.EPS

Figure 16 : Pins 17 - 18 - 19 Configuration

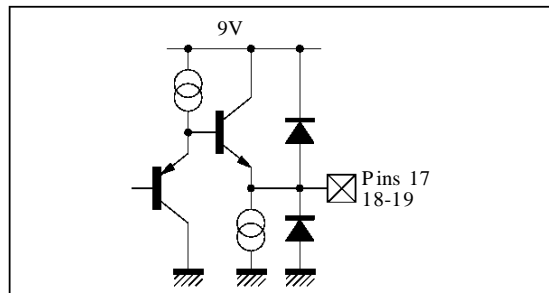

8217-18.EPS

TDA8217

APPLICATION DIAGRAM (with OSD capability)

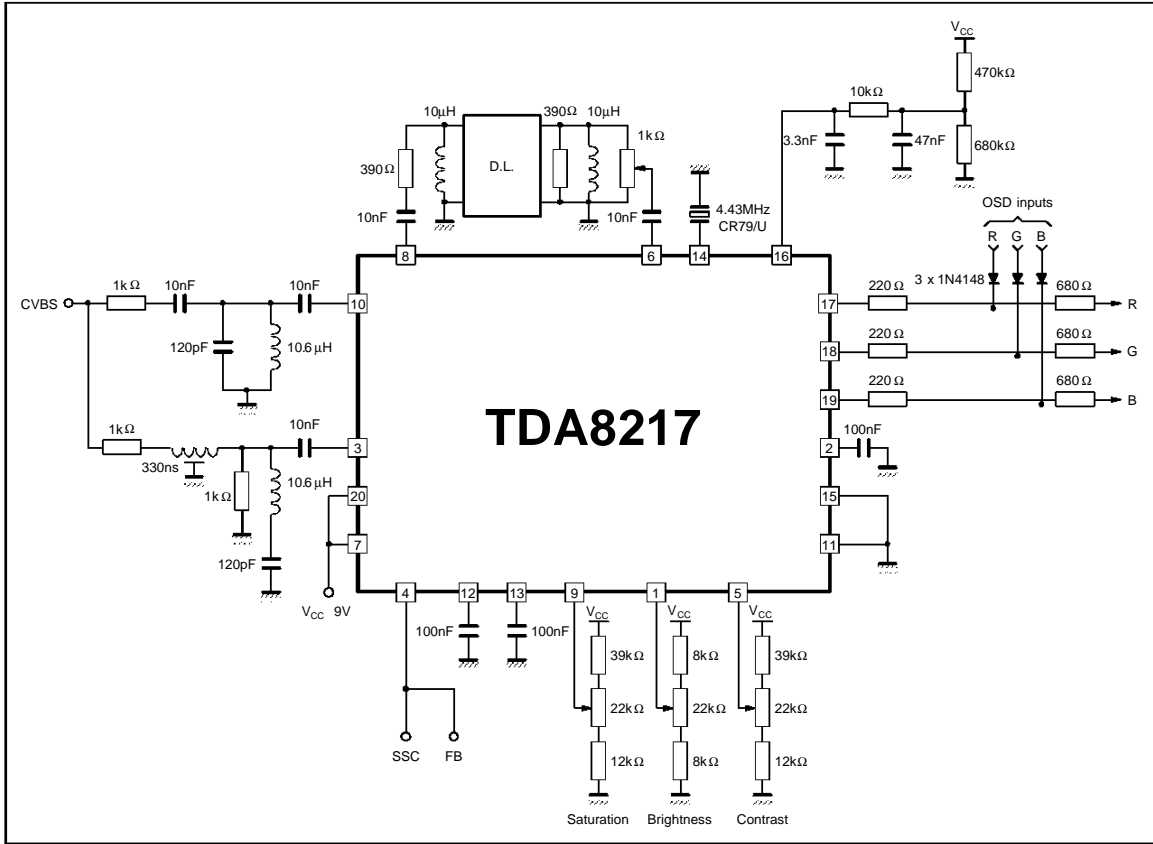

8217-19.EPS

PACKAGE MECHANICAL DATA

20 PINS - PLASTIC DIP

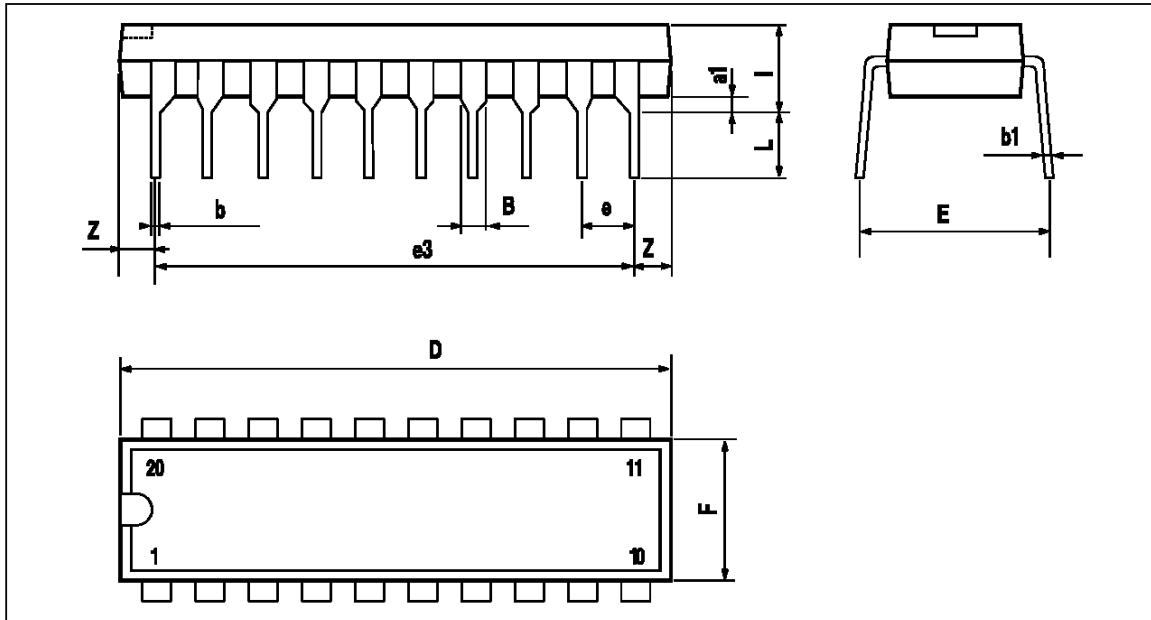

PM-DIP20.EPS

Dimensions	Millimeters			Inches		
	Min.	Typ.	Max.	Min.	Typ.	Max.
a1	0.254			0.010		
B	1.39		1.65	0.055		0.065
b		0.45			0.018	
b1		0.25			0.010	
D			25.4			1.000
E		8.5			0.335	
e		2.54			0.100	
e3		22.86			0.900	
F			7.1			0.280
l			3.93			0.155
L		3.3			0.130	
Z			1.34			0.053

DIP20.TBL

Information furnished is believed to be accurate and reliable. However, SGS-THOMSON Microelectronics assumes no responsibility for the consequences of use of such information nor for any infringement of patents or other rights of third parties which may result from its use. No licence is granted by implication or otherwise under any patent or patent rights of SGS-THOMSON Microelectronics. Specifications mentioned in this publication are subject to change without notice. This publication supersedes and replaces all information previously supplied. SGS-THOMSON Microelectronics products are not authorized for use as critical components in life support devices or systems without express written approval of SGS-THOMSON Microelectronics.

© 1996 SGS-THOMSON Microelectronics - All Rights Reserved

Purchase of μ C Components of SGS-THOMSON Microelectronics, conveys a license under the Philips μ C Patent. Rights to use these components in a μ C system, is granted provided that the system conforms to the μ C Standard Specifications as defined by Philips.

SGS-THOMSON Microelectronics GROUP OF COMPANIES

Australia - Brazil - Canada - China - France - Germany - Hong Kong - Italy - Japan - Korea - Malaysia - Malta - Morocco
The Netherlands - Singapore - Spain - Sweden - Switzerland - Taiwan - Thailand - United Kingdom - U.S.A.