

## 4 × 25 W BTL quad car radio power amplifier

## TDA8567Q

### FEATURES

- Requires very few external components
- High output power
- Low output offset voltage
- Fixed gain
- Diagnostic facility (distortion, short-circuit and temperature pre-warning)
- Good ripple rejection
- Mode select switch (operating, mute and standby)
- Load dump protection
- Short-circuit safe to ground and to  $V_P$  and across the load
- Low power dissipation in any short-circuit condition
- Thermally protected
- Reverse polarity safe
- Electrostatic discharge protection
- No switch-on/switch-off plop
- Flexible leads
- Low thermal resistance
- Pin compatible with the TDA8568Q, except for the gain.

### GENERAL DESCRIPTION

The TDA8567Q is an integrated class-B output amplifier in a 23-lead Single-In-Line (SIL) plastic power package. It contains four amplifiers in BTL configuration, each with a gain of 26 dB. The output power is 4 × 25 W in a 4  $\Omega$  load.

### APPLICATIONS

- The device is primarily developed for car radio applications.

### QUICK REFERENCE DATA

SYMBOL	PARAMETER	CONDITIONS	MIN.	TYP.	MAX.	UNIT
$V_P$	operating supply voltage		6	14.4	18	V
$I_{ORM}$	repetitive peak output current		–	–	7.5	A
$I_{q(tot)}$	total quiescent current		–	230	–	mA
$I_{stb}$	standby current		–	0.2	100	$\mu$ A
$I_{sw}$	switch-on current		–	–	80	$\mu$ A
$ Z_i $	input impedance		25	30	–	k $\Omega$
$P_o$	output power	THD = 10%	–	25	–	W
SVRR	supply voltage ripple rejection	$R_s = 0 \Omega$	–	60	–	dB
$\alpha_{cs}$	channel separation	$R_s = 10 \text{ k}\Omega$	–	50	–	dB
$G_v$	closed loop voltage gain		25	26	27	dB
$V_{n(o)}$	noise output voltage	$R_s = 0 \Omega$	–	–	120	$\mu$ V
$ \Delta V_O $	DC output offset voltage		–	–	150	mV

### ORDERING INFORMATION

TYPE NUMBER	PACKAGE		
	NAME	DESCRIPTION	VERSION
TDA8567Q	DBS23P	plastic DIL-bent-SIL power package; 23 leads (straight lead length 3.2 mm)	SOT411-1

4 × 25 W BTL quad car radio power amplifier

TDA8567Q

BLOCK DIAGRAM

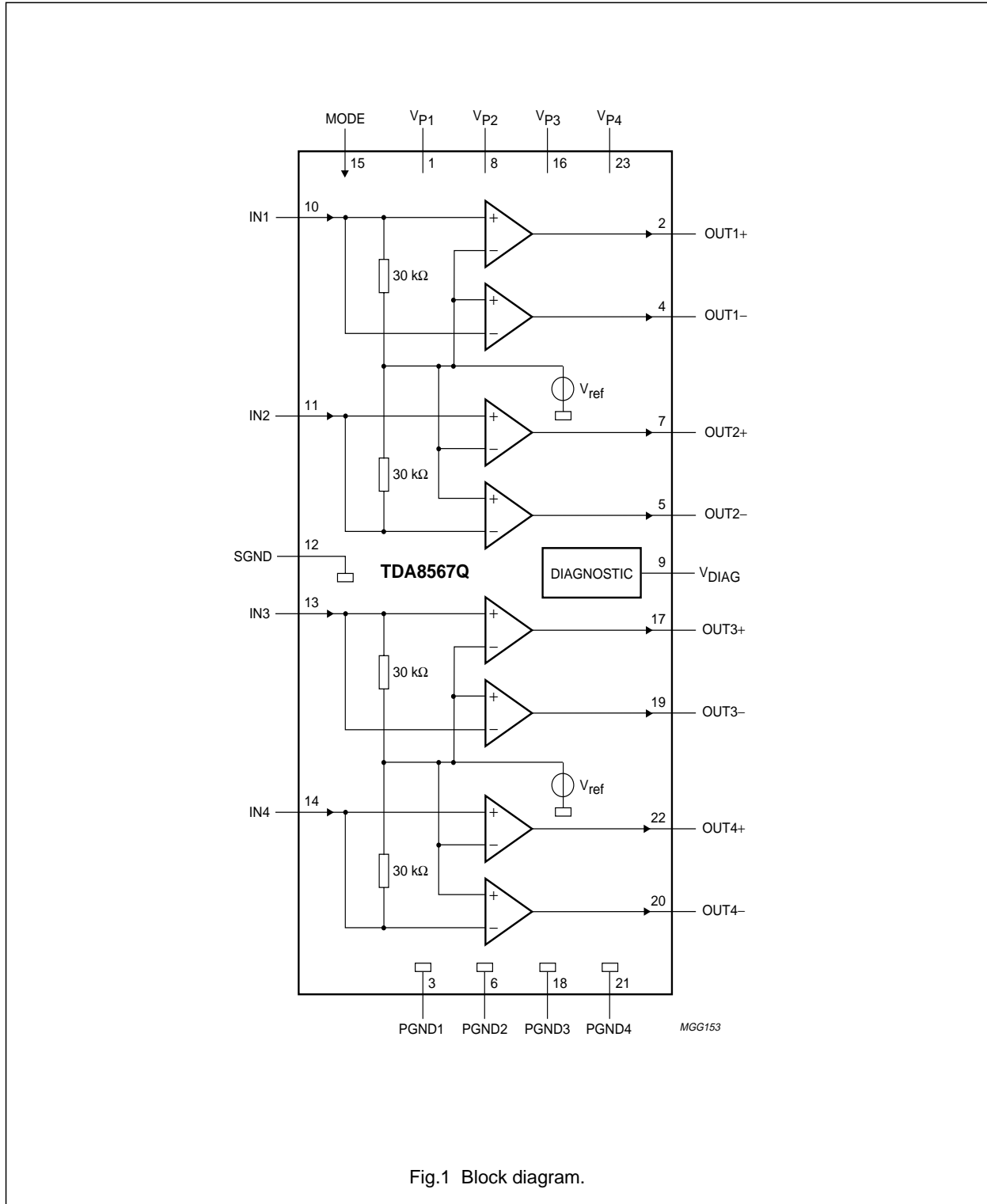

Fig.1 Block diagram.

# 4 × 25 W BTL quad car radio power amplifier

## TDA8567Q

### PINNING

SYMBOL	PIN	DESCRIPTION
V <sub>P1</sub>	1	supply voltage 1
OUT1+	2	output 1+
PGND1	3	power ground 1
OUT1-	4	output 1-
OUT2-	5	output 2-
PGND2	6	power ground 2
OUT2+	7	output 2+
V <sub>P2</sub>	8	supply voltage 2
V <sub>DIAG</sub>	9	diagnostic output
IN1	10	input 1
IN2	11	input 2
SGND	12	signal ground
IN3	13	input 3
IN4	14	input 4
MODE	15	mode select switch input
V <sub>P3</sub>	16	supply voltage 3
OUT3+	17	output 3+
PGND3	18	power ground 3
OUT3-	19	output 3-
OUT4-	20	output 4-
PGND4	21	power ground 4
OUT4+	22	output 4+
V <sub>P4</sub>	23	supply voltage 4

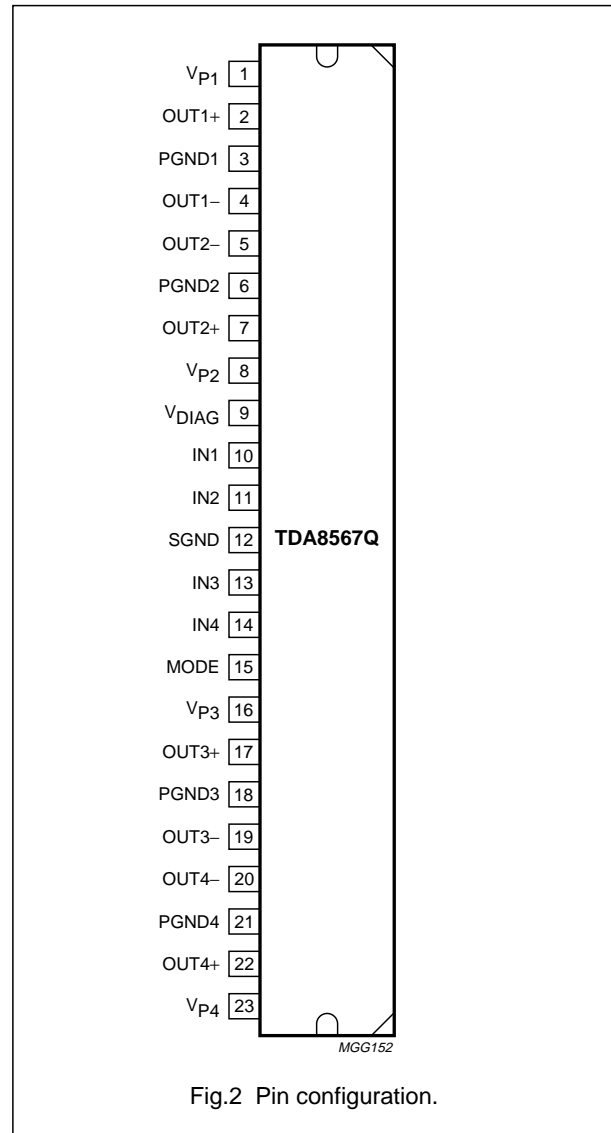

## 4 × 25 W BTL quad car radio power amplifier

TDA8567Q

### FUNCTIONAL DESCRIPTION

The TDA8567Q contains four identical amplifiers which can be used for bridge applications. The gain of each amplifier is fixed at 26 dB.

#### Mode select switch (pin 15)

- Standby: low supply current (<100  $\mu$ A)
- Mute: input signal suppressed
- Operating: normal on condition.

Since this pin has a low input current (<80  $\mu$ A), a low cost supply switch can be applied.

To avoid switch-on plops, it is advised to keep the amplifier in the mute mode during  $\geq 150$  ms (charging of the input capacitors at pins 10, 11, 13 and 14). When switching from standby to mute, the slope should be at least 18 V/s.

This can be realized by:

- Microprocessor control
- External timing circuit (see Fig.3).

#### Diagnostic output (pin 9)

##### DYNAMIC DISTORTION DETECTOR (DDD)

At the onset of clipping of one or more output stages, the dynamic distortion detector becomes active and pin 9 goes LOW. This information can be used to drive a sound processor or DC volume control to attenuate the input signal and so limit the distortion. The output level of pin 9 is independent of the number of channels that are clipping (see Fig.4).

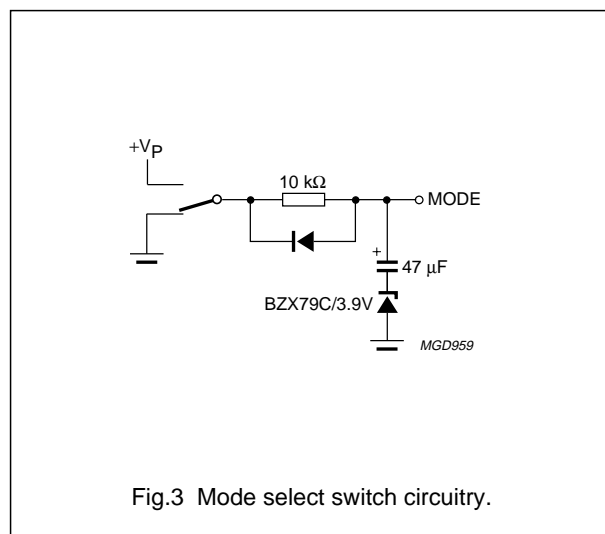

Fig.3 Mode select switch circuitry.

### SHORT-CIRCUIT DIAGNOSTIC

When a short-circuit occurs at one or more outputs to ground or to the supply voltage, the output stages are switched off until the short-circuit is removed and the device is switched on again, with a delay of approximately 10 ms after removal of the short-circuit. During this short-circuit condition, pin 9 is continuously LOW.

When a short-circuit occurs across the load of one or more channels, the output stages are switched off during approximately 10 ms. After that time it is checked during approximately 50  $\mu$ s to determine whether the short-circuit is still present.

Due to this duty cycle of 50  $\mu$ s/10 ms the average current consumption during this short-circuit condition is very low.

During this short-circuit condition, pin 9 is LOW for 10 ms and HIGH for 50  $\mu$ s (see Fig.5). The protection circuits of all channels are coupled. This means that if a short-circuit condition occurs in **one** of the channels, **all** channels are switched off. Consequently, the power dissipation in any short-circuit condition is very low.

### TEMPERATURE PRE-WARNING

When the virtual junction temperature  $T_{vj}$  reaches 145 °C, pin 9 goes LOW.

### OPEN COLLECTOR OUTPUTS

The diagnostic pin has an open collector output, so more devices can be tied together. An external pull-up resistor is needed.

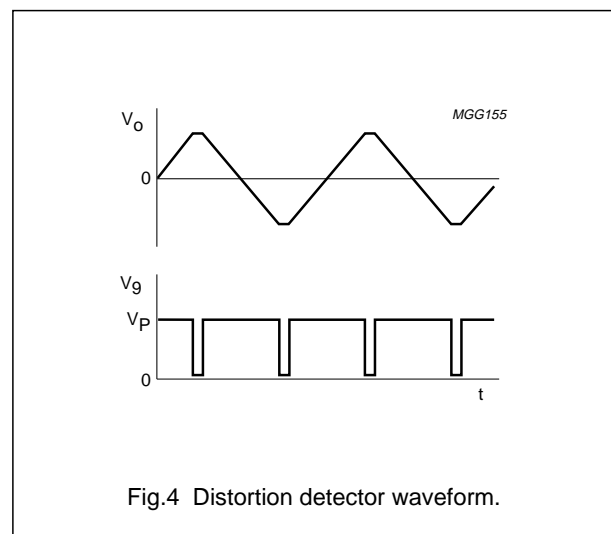

Fig.4 Distortion detector waveform.

4 × 25 W BTL quad car radio power amplifier

TDA8567Q

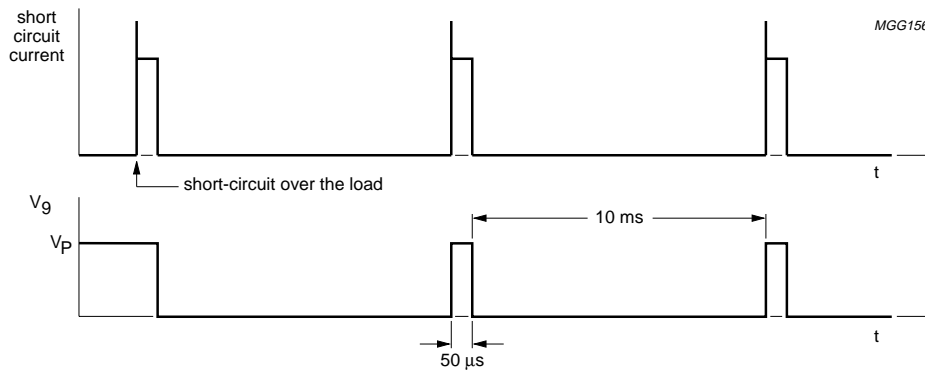

Fig.5 Short-circuit waveform.

# 4 × 25 W BTL quad car radio power amplifier

TDA8567Q

## LIMITING VALUES

In accordance with the Absolute Maximum Rating System (IEC 134).

SYMBOL	PARAMETER	CONDITIONS	MIN.	MAX.	UNIT
$V_P$	supply voltage	operating	–	18	V
		non-operating	–	30	V
		load dump protection; during 50 ms; $t_r \geq 2.5$ ms	–	45	V
$V_{sc(safe)}$	short-circuit safe voltage		–	18	V
$V_{rp}$	reverse polarity voltage		–	6	V
$I_{OSM}$	non-repetitive peak output current		–	10	A
$I_{ORM}$	repetitive peak output current		–	7.5	A
$P_{tot}$	total power dissipation		–	60	W
$T_{stg}$	storage temperature		–55	+150	°C
$T_{amb}$	operating ambient temperature		–40	+85	°C
$T_{vj}$	virtual junction temperature		–	150	°C

## THERMAL CHARACTERISTICS

SYMBOL	PARAMETER	VALUE	UNIT
$R_{th\ j-a}$	thermal resistance from junction to ambient in free air	40	K/W
$R_{th\ j-c}$	thermal resistance from junction to case (see Fig.6)	1	K/W

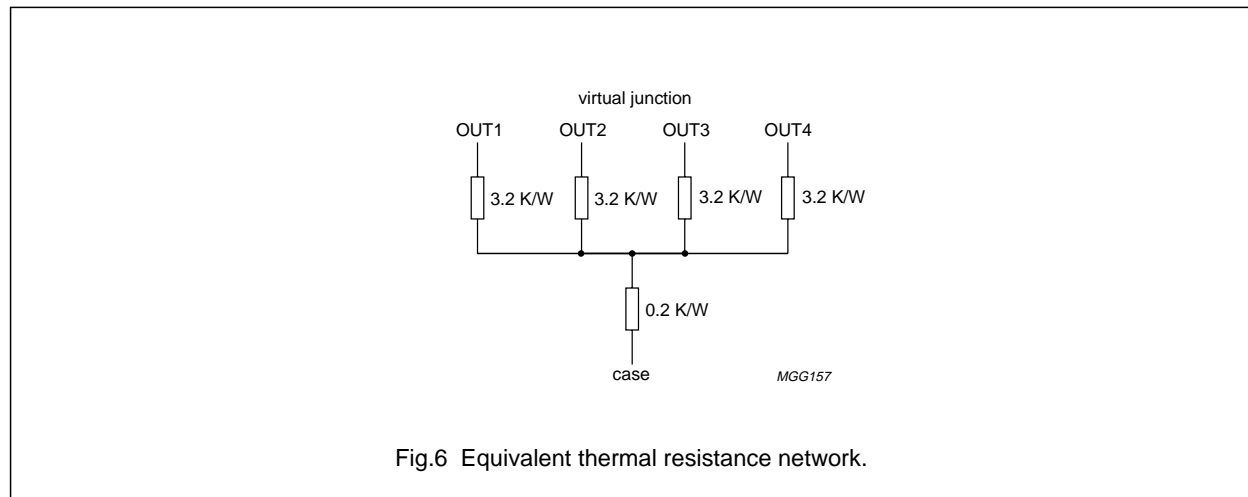

## QUALITY SPECIFICATION

In accordance with "SNW-FQ-611E". The number of the quality specification can be found in the "Quality Reference Handbook". The handbook can be ordered using the code 9397 750 00192.

# 4 × 25 W BTL quad car radio power amplifier

TDA8567Q

## DC CHARACTERISTICS

$V_P = 14.4\text{ V}$ ;  $T_{\text{amb}} = 25\text{ °C}$ ; measured in Fig.7; unless otherwise specified.

SYMBOL	PARAMETER	CONDITIONS	MIN.	TYP.	MAX.	UNIT
<b>Supply</b>						
$V_P$	supply voltage	note 1	6	14.4	18	V
$I_{q(\text{tot})}$	total quiescent current	$R_L = \infty$	–	230	360	mA
<b>Operating condition</b>						
$V_{15}$	mode select switch level		8.5	–	$V_P$	V
$I_{15}$	mode select switch current	$V_{15} = 14.4\text{ V}$	–	30	80	$\mu\text{A}$
$V_O$	output voltage	note 2	–	7.0	–	V
$ \Delta V_O $	output offset voltage		–	–	150	mV
<b>Mute condition</b>						
$V_{15}$	mode select switch level		3.3	–	6.4	V
$V_O$	output voltage	note 2	–	7.0	–	V
$ \Delta V_O $	output offset voltage		–	–	150	mV
<b>Standby condition</b>						
$V_{15}$	mode select switch level		0	–	2	V
$I_{\text{stb}}$	standby current		–	0.2	100	$\mu\text{A}$
<b>Diagnostic</b>						
$V_9$	diagnostic output voltage	during any fault condition	–	–	0.6	V
$T_{\text{vj}}$	temperature pre-warning	$V_9 = 0.6\text{ V}$	–	145	–	$^{\circ}\text{C}$

### Notes

1. The circuit is DC adjusted at  $V_P = 6$  to  $18\text{ V}$  and AC operating at  $V_P = 8.5$  to  $18\text{ V}$ .
2. At  $18\text{ V} < V_P < 30\text{ V}$  the DC output voltage  $\leq \frac{1}{2}V_P$ .

# 4 × 25 W BTL quad car radio power amplifier

TDA8567Q

## AC CHARACTERISTICS

$V_P = 14.4\text{ V}$ ;  $R_L = 4\ \Omega$ ;  $f = 1\text{ kHz}$ ;  $T_{amb} = 25\text{ °C}$ ; measured in Fig.7; unless otherwise specified.

SYMBOL	PARAMETER	CONDITIONS	MIN.	TYP.	MAX.	UNIT
$P_o$	output power	THD = 0.5%	16	19	–	W
		THD = 10%	21	25	–	W
		THD = 30%	28	35	–	W
		$V_P = 13.2\text{ V}$ ; THD = 0.5%	–	15	–	W
		$V_P = 13.2\text{ V}$ ; THD = 10%	–	21	–	W
THD	total harmonic distortion	$P_o = 1\text{ W}$	–	0.05	–	%
		$V_g \leq 0.6\text{ V}$ ; note 8	–	10	–	%
$B_p$	power bandwidth	THD = 0.5%; $P_o = -1\text{ dB}$ with respect to 16 W	–	20 to 20000	–	Hz
$f_{ro(l)}$	low frequency roll-off	at $-1\text{ dB}$ ; note 1	–	25	–	Hz
$f_{ro(h)}$	high frequency roll-off	at $-1\text{ dB}$	20	–	–	kHz
$G_v$	closed loop voltage gain		25	26	27	dB
SVRR	supply voltage ripple rejection	on; note 2	50	–	–	dB
		mute; note 2	50	–	–	dB
		standby; note 2	80	–	–	dB
$ Z_i $	input impedance		25	30	38	k $\Omega$
$V_{n(o)}$	noise output voltage	on; note 3	–	85	120	$\mu\text{V}$
		on; note 4	–	100	–	$\mu\text{V}$
		mute; note 5	–	60	–	$\mu\text{V}$
$\alpha_{cs}$	channel separation	note 6	45	–	–	dB
$ \Delta G_v $	channel unbalance		–	–	1	dB
$V_o$	output signal in mute	note 7	–	–	2	mV

### Notes

1. Frequency response externally fixed.
2.  $V_{ripple} = V_{ripple(max)} = 2\text{ V}$  (p-p);  $R_s = 0\ \Omega$ .
3.  $B = 20\text{ Hz}$  to  $20\text{ kHz}$ ;  $R_s = 0\ \Omega$ .
4.  $B = 20\text{ Hz}$  to  $20\text{ kHz}$ ;  $R_s = 10\text{ k}\Omega$ .
5.  $B = 20\text{ Hz}$  to  $20\text{ kHz}$ ; independent of  $R_s$ .
6.  $P_o = 16\text{ W}$ ;  $R_s = 10\text{ k}\Omega$ .
7.  $V_i = V_{i(max)} = 1\text{ V}$  (RMS).
8. Dynamic Distortion Detector (DDD) active, pin 9 is set to logic 0.

# 4 × 25 W BTL quad car radio power amplifier

TDA8567Q

## TEST AND APPLICATION INFORMATION

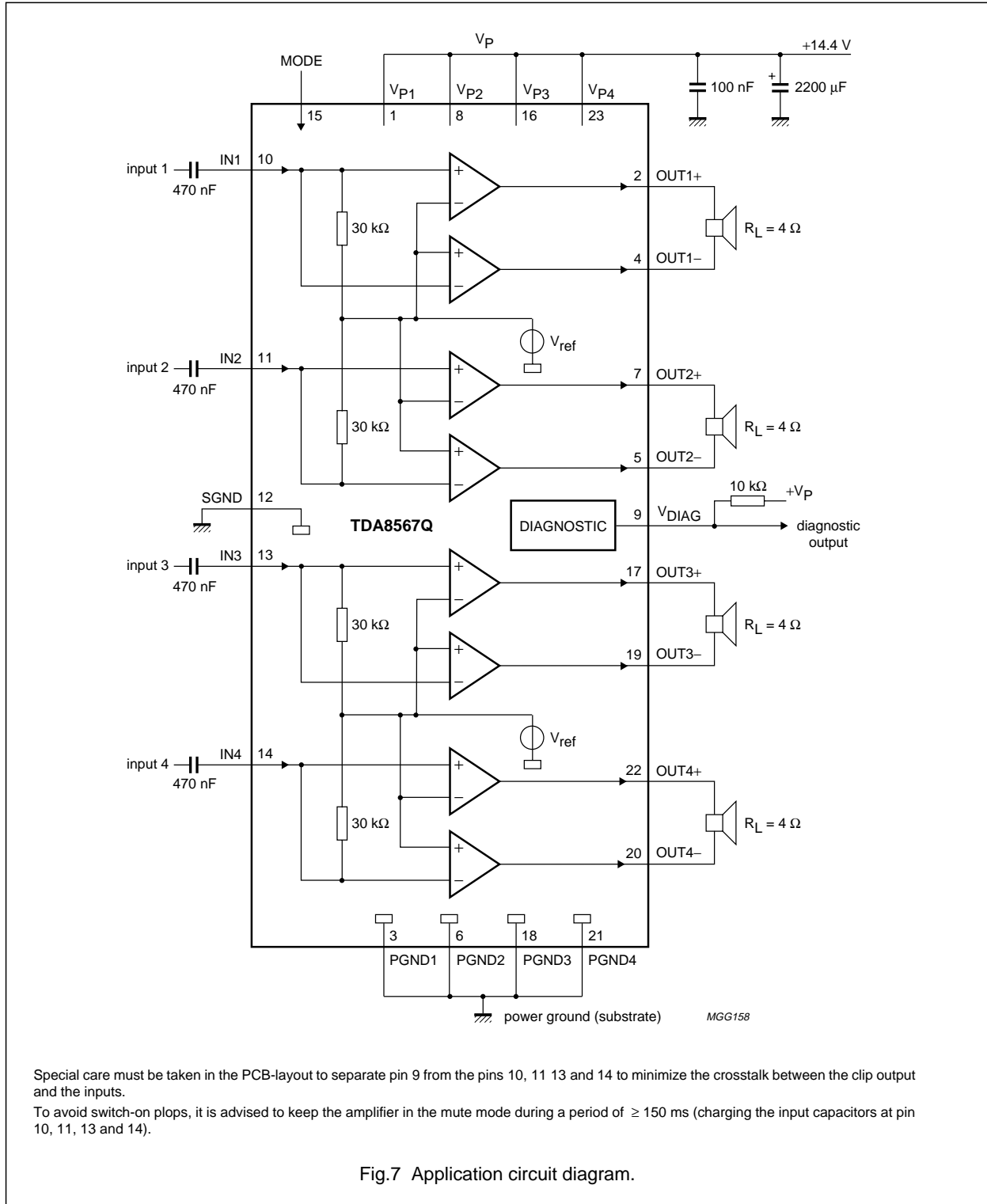

# 4 × 25 W BTL quad car radio power amplifier

TDA8567Q

## Test information

Figures 8 to 13 have the following conditions:  $V_P = 14.4\text{ V}$ ;  $R_L = 4\ \Omega$ ;  $f = 1\text{ kHz}$ ; 80 kHz filter used; unless otherwise specified.

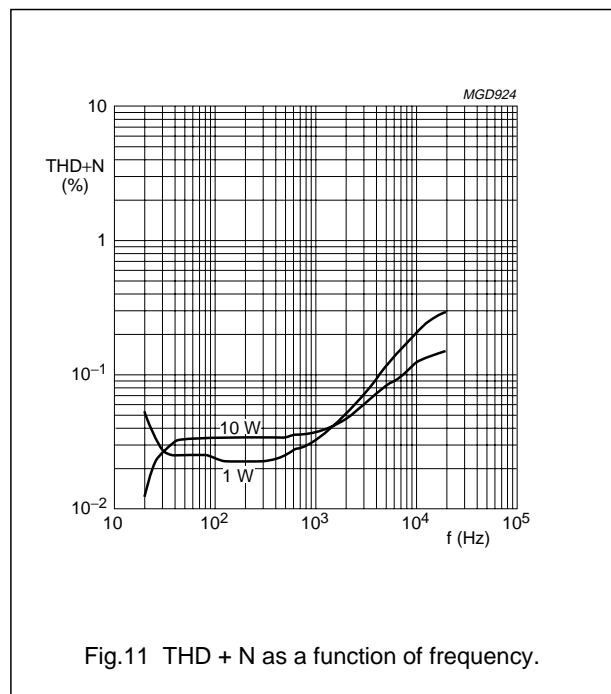
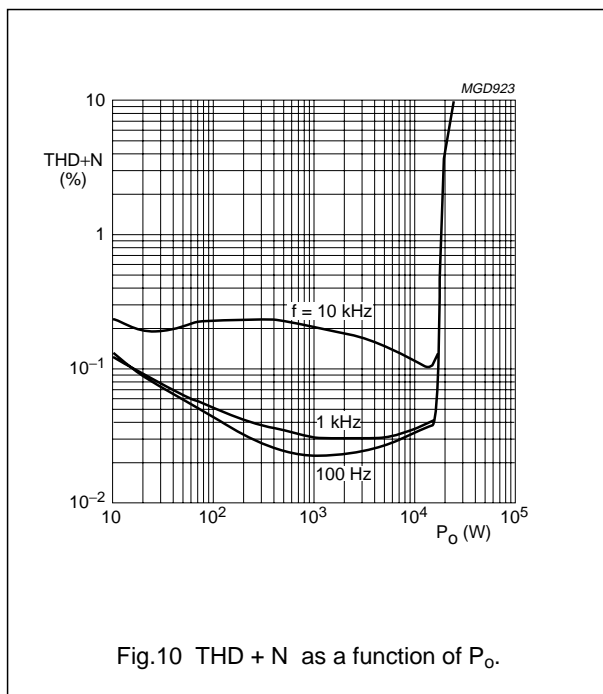
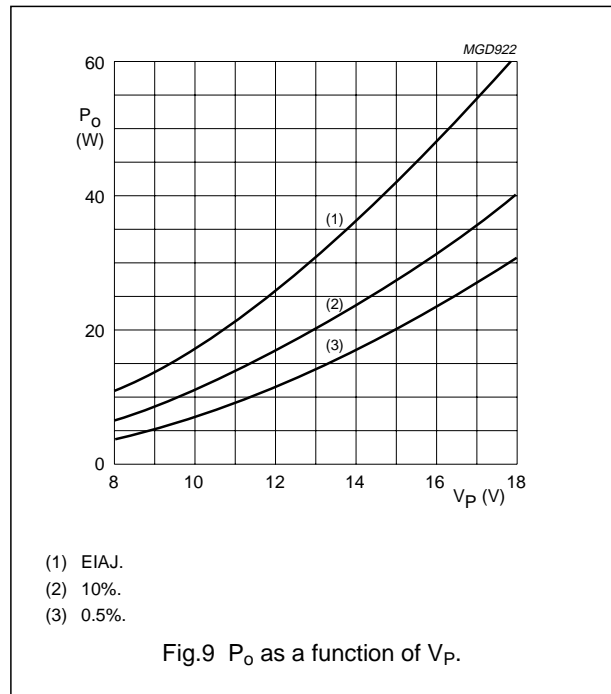
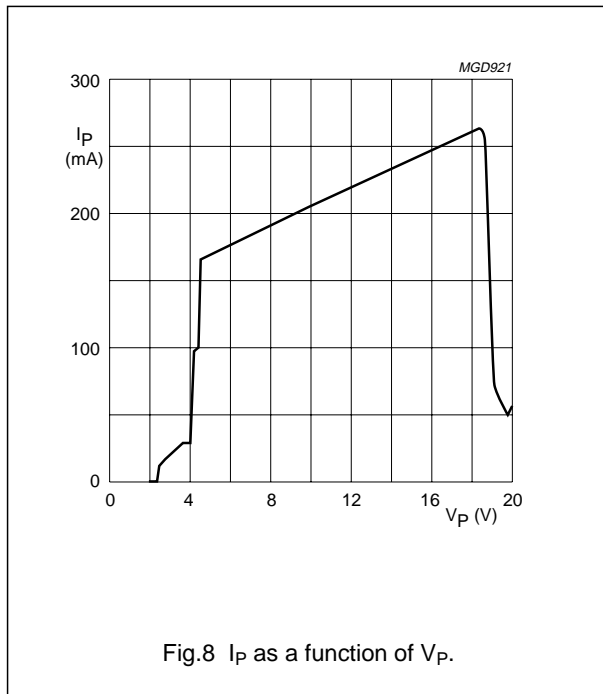

4 × 25 W BTL quad car radio power amplifier

TDA8567Q

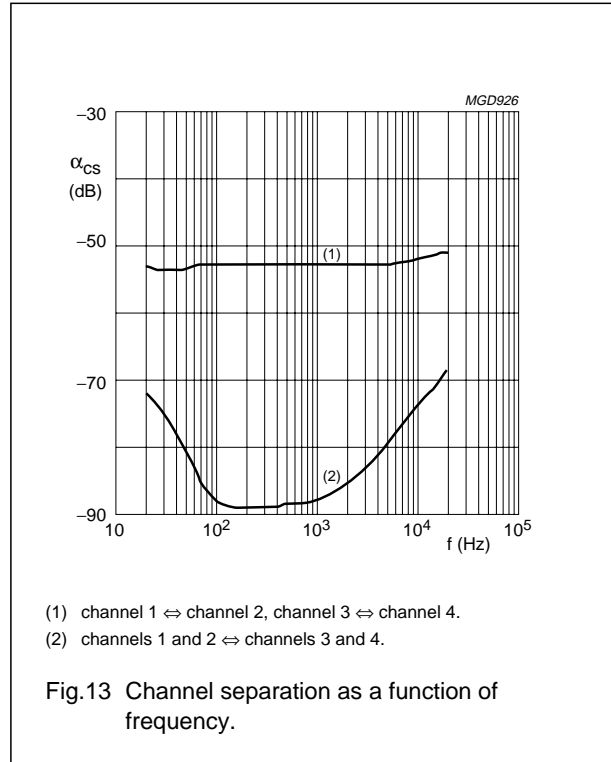
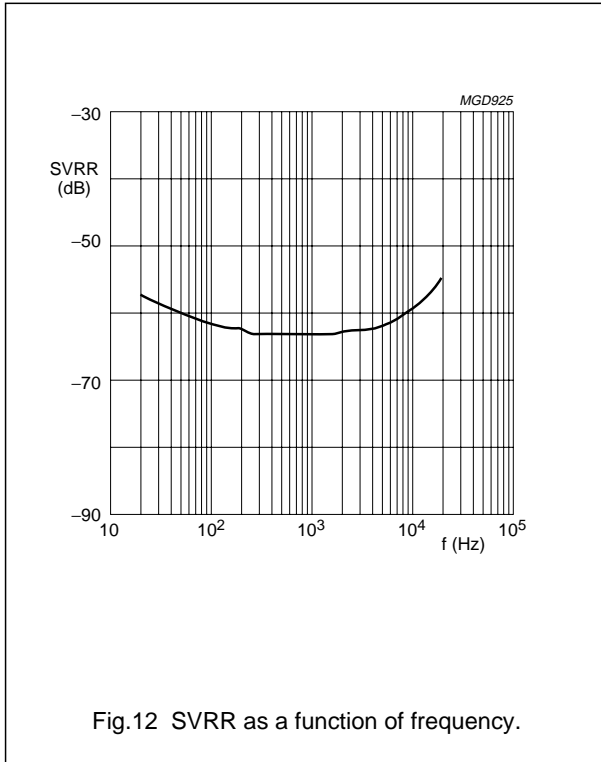

4 × 25 W BTL quad car radio power amplifier

TDA8567Q

PCB layout

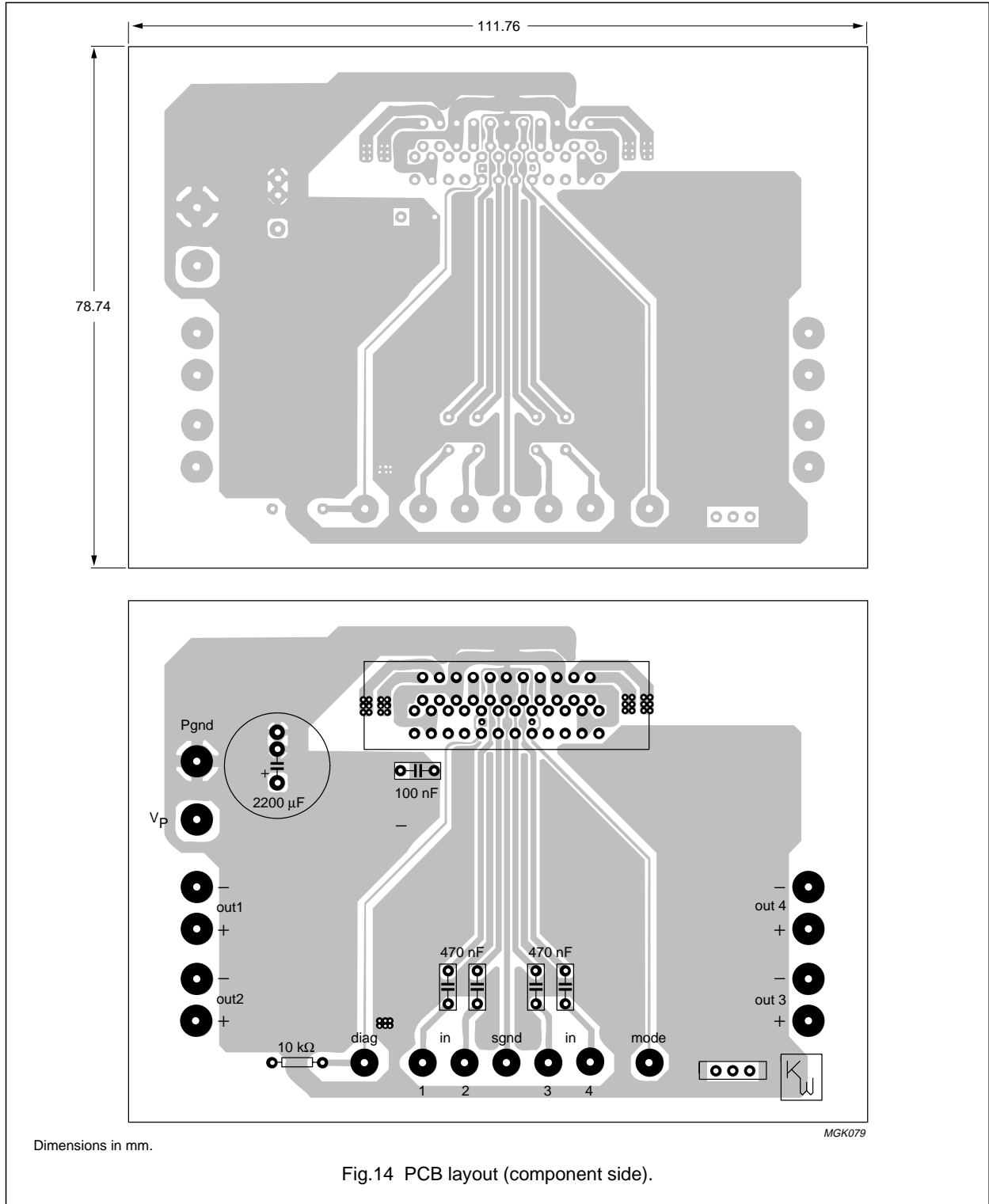
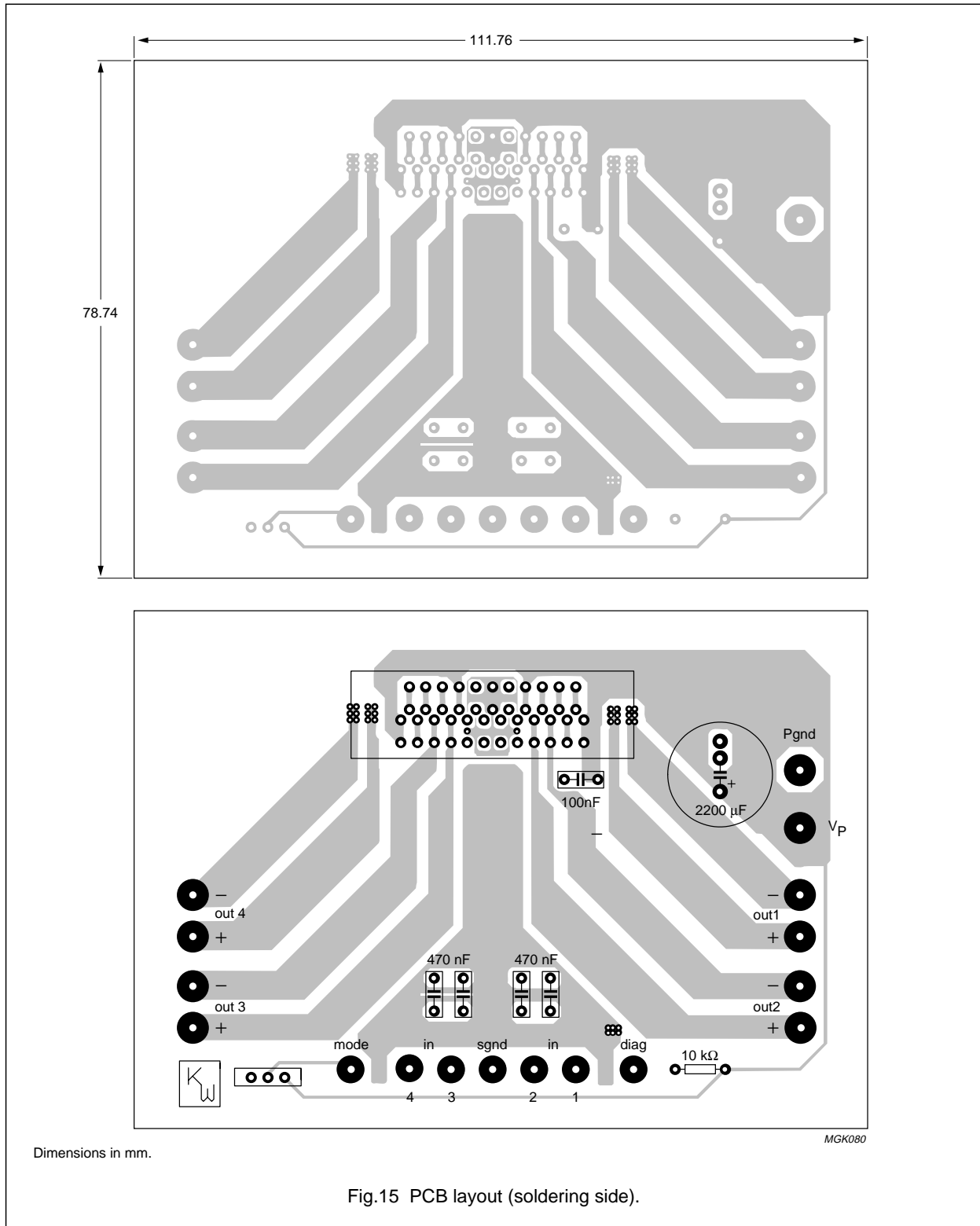

Fig.14 PCB layout (component side).

# 4 × 25 W BTL quad car radio power amplifier

TDA8567Q



# 4 × 25 W BTL quad car radio power amplifier

TDA8567Q

## PACKAGE OUTLINE

DBS23P: plastic DIL-bent-SIL power package; 23 leads (straight lead length 3.2 mm)

SOT411-1

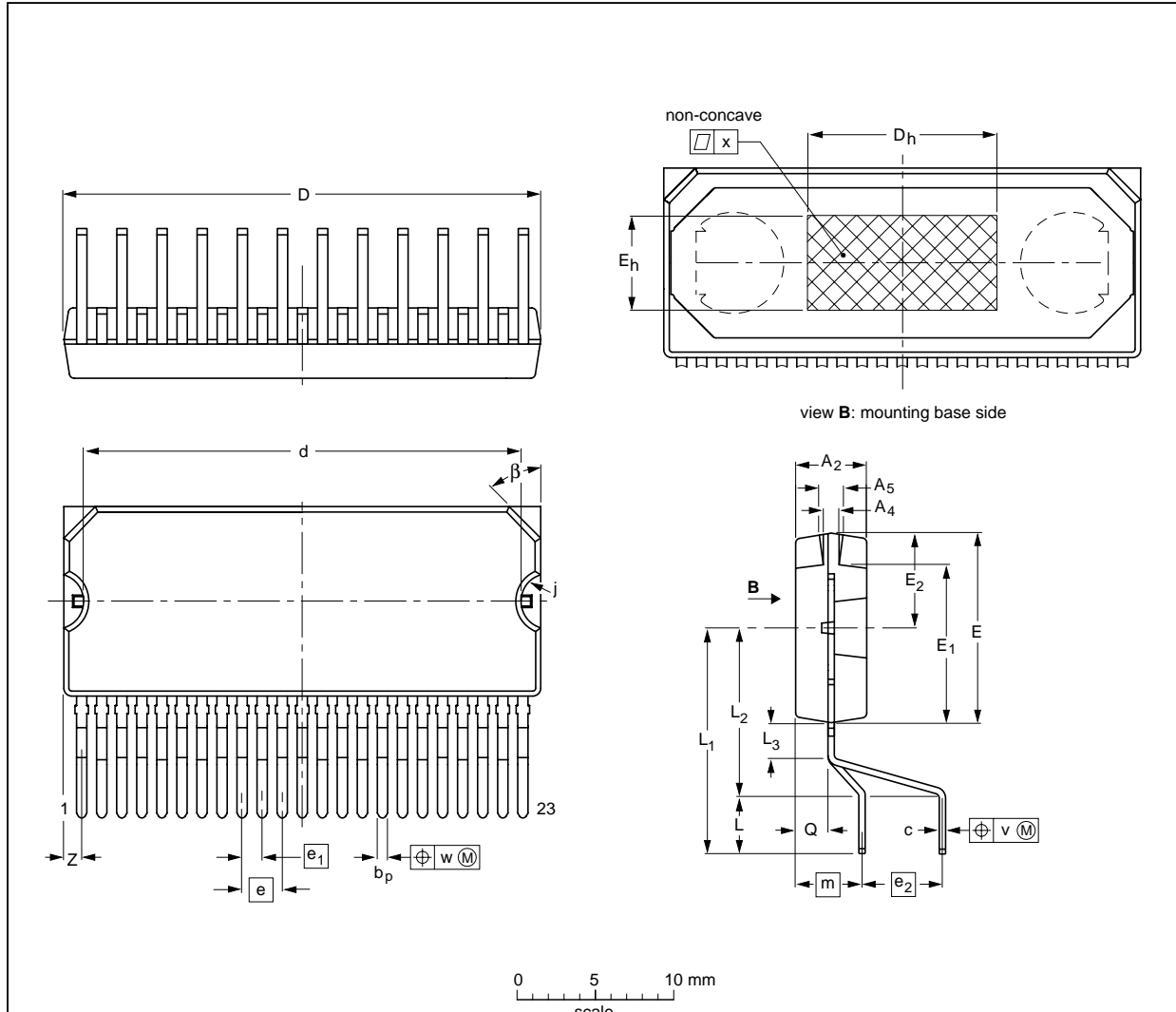

**DIMENSIONS (mm are the original dimensions)**

UNIT	A <sub>2</sub>	A <sub>4</sub>	A <sub>5</sub>	b <sub>p</sub>	c	D <sup>(1)</sup>	d	D <sub>h</sub>	E <sup>(1)</sup>	e	e <sub>1</sub>	e <sub>2</sub>	E <sub>h</sub>	E <sub>1</sub>	E <sub>2</sub>	j	L	L <sub>1</sub>	L <sub>2</sub>	L <sub>3</sub>	m	Q	v	w	x	β	Z <sup>(1)</sup>
mm	4.6 4.3	1.15 0.85	1.65 1.35	0.75 0.60	0.55 0.35	30.4 29.9	28.0 27.5	12	12.2 11.8	2.54	1.27	5.08	6	10.15 9.85	6.2 5.8	1.85 1.65	3.6 2.8	14.0 13.0	10.7 9.9	2.4 1.6	4.3	2.1 1.8	0.6	0.25	0.03	45°	1.43 0.78

**Note**

1. Plastic or metal protrusions of 0.25 mm maximum per side are not included.

OUTLINE VERSION	REFERENCES				EUROPEAN PROJECTION	ISSUE DATE
	IEC	JEDEC	EIAJ			
SOT411-1						96-10-11 98-02-20

## 4 × 25 W BTL quad car radio power amplifier

TDA8567Q

### SOLDERING

#### Introduction

There is no soldering method that is ideal for all IC packages. Wave soldering is often preferred when through-hole and surface mounted components are mixed on one printed-circuit board. However, wave soldering is not always suitable for surface mounted ICs, or for printed-circuits with high population densities. In these situations reflow soldering is often used.

This text gives a very brief insight to a complex technology. A more in-depth account of soldering ICs can be found in our *"Data Handbook IC26; Integrated Circuit Packages"* (order code 9398 652 90011).

#### Soldering by dipping or by wave

The maximum permissible temperature of the solder is 260 °C; solder at this temperature must not be in contact with the joint for more than 5 seconds. The total contact time of successive solder waves must not exceed 5 seconds.

The device may be mounted up to the seating plane, but the temperature of the plastic body must not exceed the specified maximum storage temperature ( $T_{stg\ max}$ ). If the printed-circuit board has been pre-heated, forced cooling may be necessary immediately after soldering to keep the temperature within the permissible limit.

#### Repairing soldered joints

Apply a low voltage soldering iron (less than 24 V) to the lead(s) of the package, below the seating plane or not more than 2 mm above it. If the temperature of the soldering iron bit is less than 300 °C it may remain in contact for up to 10 seconds. If the bit temperature is between 300 and 400 °C, contact may be up to 5 seconds.

### DEFINITIONS

Data sheet status	
Objective specification	This data sheet contains target or goal specifications for product development.
Preliminary specification	This data sheet contains preliminary data; supplementary data may be published later.
Product specification	This data sheet contains final product specifications.
Limiting values	
Limiting values given are in accordance with the Absolute Maximum Rating System (IEC 134). Stress above one or more of the limiting values may cause permanent damage to the device. These are stress ratings only and operation of the device at these or at any other conditions above those given in the Characteristics sections of the specification is not implied. Exposure to limiting values for extended periods may affect device reliability.	
Application information	
Where application information is given, it is advisory and does not form part of the specification.	

### LIFE SUPPORT APPLICATIONS

These products are not designed for use in life support appliances, devices, or systems where malfunction of these products can reasonably be expected to result in personal injury. Philips customers using or selling these products for use in such applications do so at their own risk and agree to fully indemnify Philips for any damages resulting from such improper use or sale.