

**VIDEO AND AUDIO SIGNALS SWITCHINGS
FOR THE PERI-TELEVISION PLUG**

- VIDEO CROSSTALK : 60 dB TYPICAL
- LOW IMPEDANCE VIDEO OUTPUT 75 Ω
- SHORT-CIRCUIT PROTECTION OF INPUTS AND OUTPUTS
- INTERNAL HORIZONTAL PLL TIME CONSTANT SWITCHING IN CASE OF VIDEO RECORDER RECEPTION

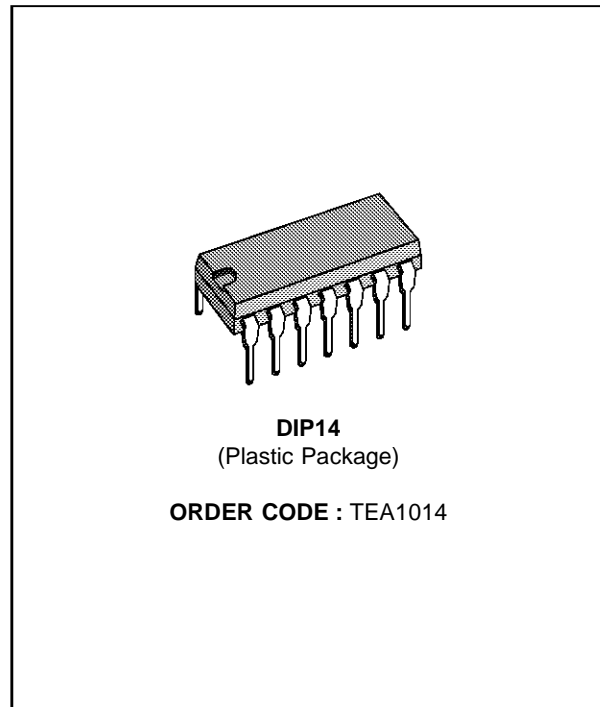

DESCRIPTION

This integrated circuit provides all video and sound switching allowing connections between the peri-TV plug and video, sound sections in the TV set. Input and output signal characteristics follow the NFC 92250/EN 50049 norms.

PIN CONNECTIONS

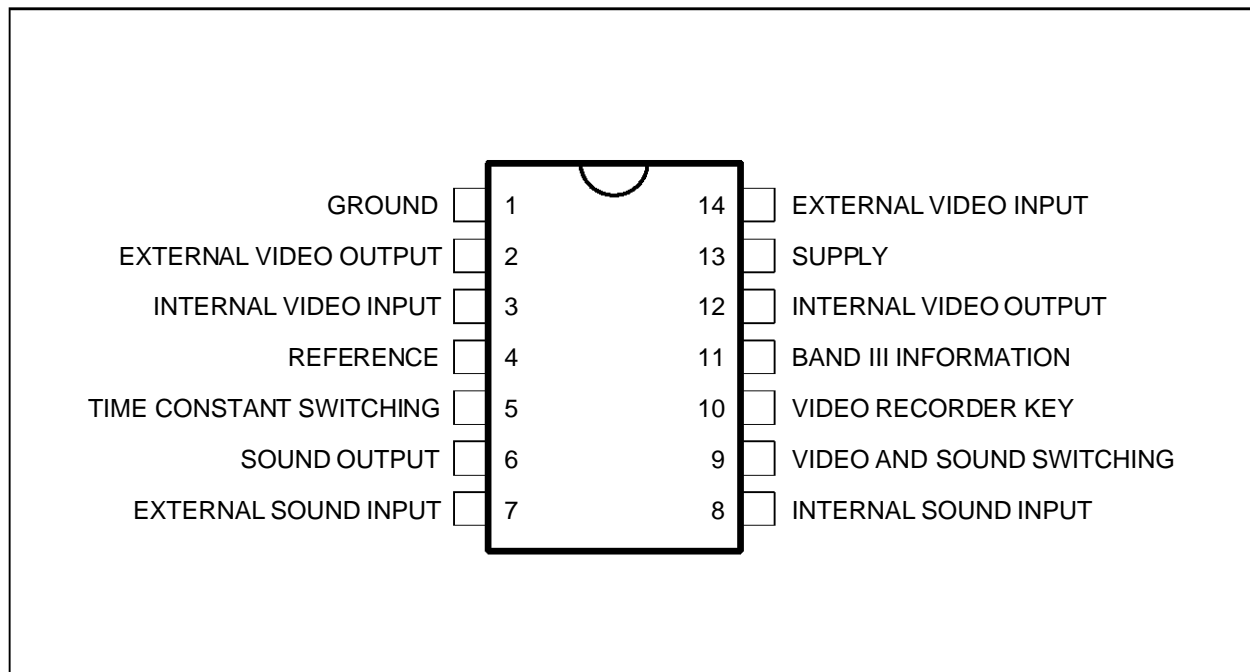

1014-01.EPS

BLOCK DIAGRAM

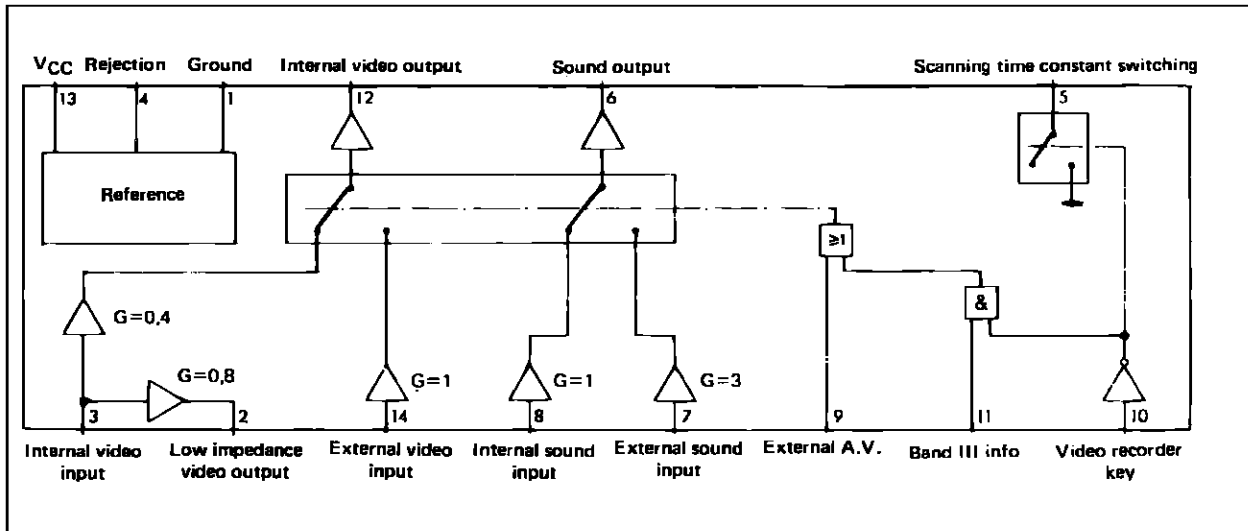

1014-02.EPS

ABSOLUTE MAXIMUM RATINGS

Symbol	Parameter	Value	Unit
V_{CC}	Supply Voltage	18	V
T_{stg}	Storage Temperature Range	- 40, + 150	°C
T_j	Junction Temperature	+ 150	°C
T_{oper}	Operating Ambient Temperature Range	0 to 70	°C

1014-01.TBL

THERMAL DATA

Symbol	Parameter	Value	Unit
$R_{th(j-a)}$	Junction Ambient Thermal Resistance	90	°C/W

1014-02.TBL

ELECTRICAL OPERATING CHARACTERISTICS

($V_{CC} = 12V$; $T_{amb} = + 25^{\circ}C$, unless otherwise specified)

Symbol	Parameter	Min.	Typ.	Max.	Unit
	Supply Current, with no Load		37	50	mA
	Internal Video Input (coming from picture FI) (pin 3) Video Signal Amplitude (positive video) Input Voltage Range (referred to D. C. input Voltage) Input Impedance Input Capacitance	- 2.9 5	2.5	6.8 + 3.9 5	V_{PP} V kΩ pF
	External Video Input (coming from peri-TV plug) (pin 14) Video Signal Amplitude (positive video) Input Voltage Range (referred to D. C. input Voltage) Input Impedance Input Capacitance	- 1.2 5	1	2.8 + 1.6 5	V_{PP} V kΩ pF
	TV Video Output (pin 12) Signal Amplitude Output Voltage Swing (referred to D. C. output Voltage) Output Dynamic Impedance D.C. Output Voltage (without input signal) Loading Resistance Video Bandwidth (- 1dB)	- 1.2 300 6	1 3.5	2.8 + 1.6 10	V_{PP} V Ω V Ω MHZ

1014-03.TBL

ELECTRICAL OPERATING CHARACTERISTICS (continued)(V_{CC} = 12V ; T_{amb} = + 25°C, unless otherwise specified)

Symbol	Parameter	Min.	Typ.	Max.	Unit
	Gain/internal Video Gain/external Video	- 9.5 - 1.5	- 8 0	- 6.5 + 1.5	dB dB
	External Video Output (low impedance) (pin 2) Signal Amplitude (on 150 Ω grounded) Output Voltage Swing Dynamic Output Impedance D.C. Output Voltage (without input signal) Minimum Loading Resistance (electrical performance non specified) Gain/internal Video	- 2.4 75 - 3.5	2 10 3.5 - 2	5.5 + 3.1 - 0.5	V _{PP} V Ω V Ω dB
	Output Video Signals Characteristics Video Rejection between two Inputs (1 MHz) Differential Group Delay Linearity Distortion Luma (test line 17) Chroma (test line 331) Intermodulation Luma-chroma (test line 331) Supply Voltage Rejection	- 55 45	 2 2 5	 20 	dB ns % % % dB
	Internal Sound Input (pin 8) Input Signal Input Impedance		0.3 20	2	V _{eff} kΩ
	External Sound Input (pin 7) Input Signal Input Impedance		0.1 20	0.7	V _{eff} kΩ
	Sound Output (pin 6) Output Signal Amplitude Output Voltage Swing Distortion (V _O = 0.6 V _{eff}) Bandwidth Output Impedance Load Impedance Gain/internal Input Gain/external Input Supply Voltage Rejection Crosstalk Video/sound Crosstalk	16 2 - 1.5 8 60 - 60 - 60	0.3 2 40 0 9.5	0.5 + 1.5 11	V _{eff} V _{eff} % kHz Ω kΩ dB dB dB dB
	LOGIC External A. V. Input (peri-TV plug) (pin 9) Unactive Low Level or Unconnected Pin (logic state 0) – (TV receiving) Active High Level (logic state 1) (ext. receiving) Input Impedance	0 9	 10	3 V _{CC}	V V kΩ
	"Band III" Input (pin 11) Unactive Low Level or Unconnected Pin (logic state 0) Active High Level (logic state 1) Input Impedance High Level Input Current Low Level	0 9	 10	+ 3 V _{CC} 1	V V kΩ μA
	Video-recorder Key Input (pin 10) Unactive High Level or Unconnected Pin (logic state 1) Active Low Level (logic state 0) Input Impedance	9 0	 10	V _{CC} 3	V V kΩ
	Open Collector Output (time-constant switching) (pin 5) Leakage Current (open collector) Maximum Low Level Voltage (I(5) = 4mA)			1 1.5	μA V

1014-04.TEL

CIRCUIT DESCRIPTION

The main functions of the I.C. are following :

Video Switching

- 2 electronically switched inputs :
 - one 2.5V_{PP} input for internal video.
 - one 1V_{PP} input for signal coming from the peri-TV plug.
- 2 outputs :
 - 1V_{PP} output (low impedance 75Ω) for peri-TV plug.
 - 1V_{PP} output low impedance for video section of the TV set.

Each input and output is protected from ground short-circuit. The 75Ω output is protected through a 75Ω resistor.

Audio Switching

- Two electronically switched inputs :
 - 300mV rms input coming from internal audio.
 - 100mV rms input coming from the peri-TV plug
- one low impedance output 300mV_{RMS}.

Inputs and outputs are also protected against ground short-circuit.

Switching Logic

The logic takes into account the informations on 3 pins.

- Internal or external video and sound (pin 8 peri TV plug)
- Band III information
- Video recorder key.

External Video and Audio signals are selected in two cases.

- When there is a voltage information coming from peri-TV plug.
- When the video recorder key is selected (on TV front panel) and programmed on band III.

This I.C. includes an internal switch (open collector transistor) which commutes the time constant of the horizontal PLL circuit in case of video recorder reception.

APPLICATION CIRCUIT

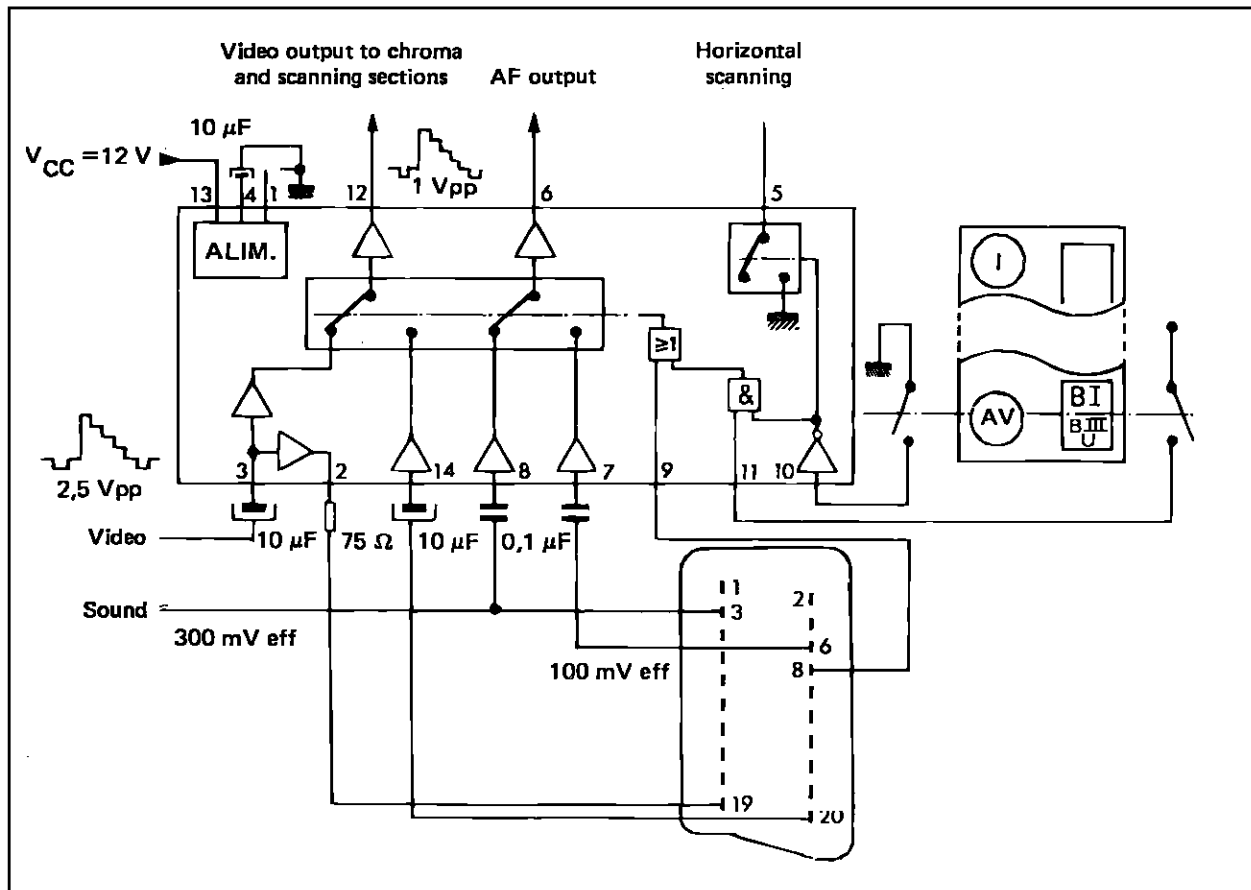

1014-03.EPS

SAFETY INFORMATION FOR CRITICAL APPLICATIONS

Voltage on pin 9 must not exceed the V_{CC} voltage on pin 13. In case of risk of over voltage, use the protection as described in Figure 2.

All connections to Peritel plug are terminated by low

impedance loads (75W), except the external sound input.

In case of risk of electrostatic discharge, use the protection as described in Figure 3.

Figure 1 : Typical Connection Between Peritel Plug and TEA2014

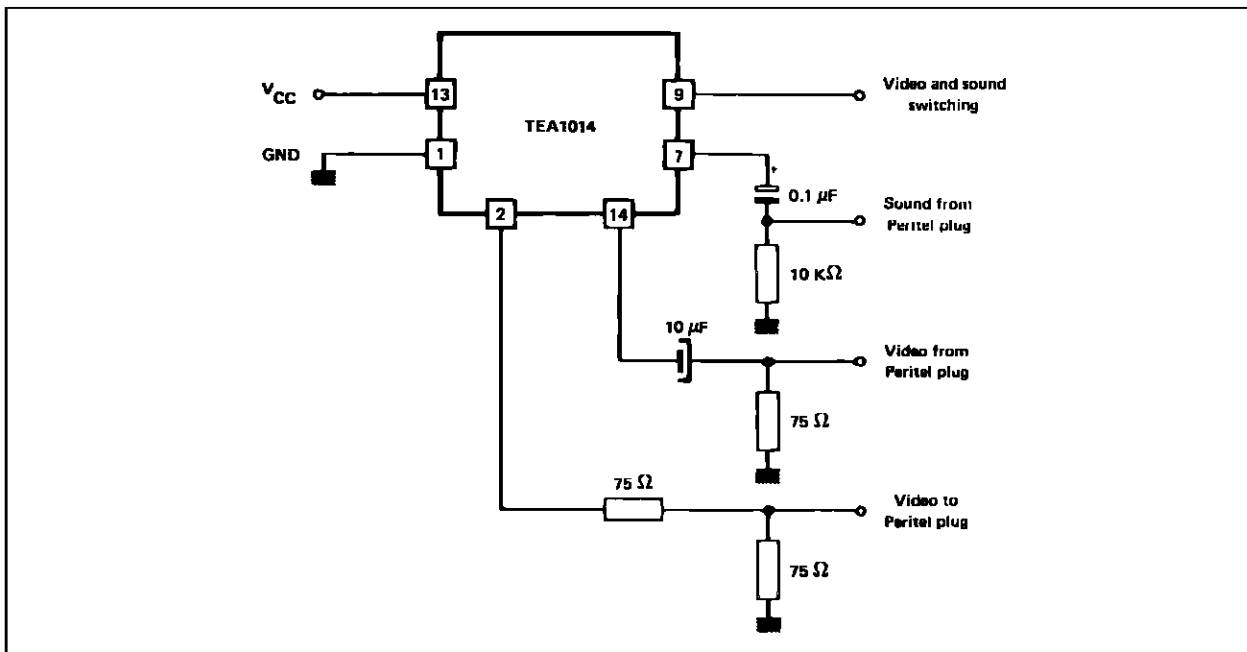

1014-04.EPS

Figure 2

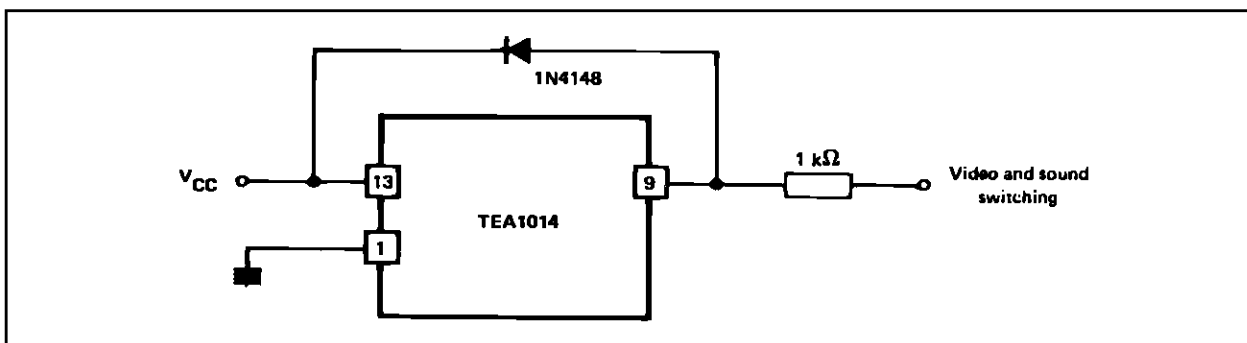

1014-05.EPS

Figure 3

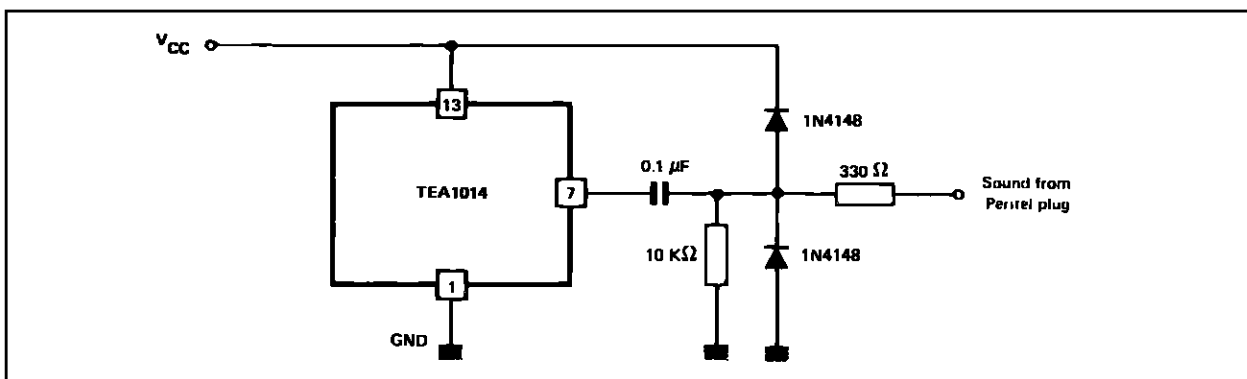

1014-06.EPS

PACKAGE MECHANICAL DATA
14 PINS - PLASTIC DIP

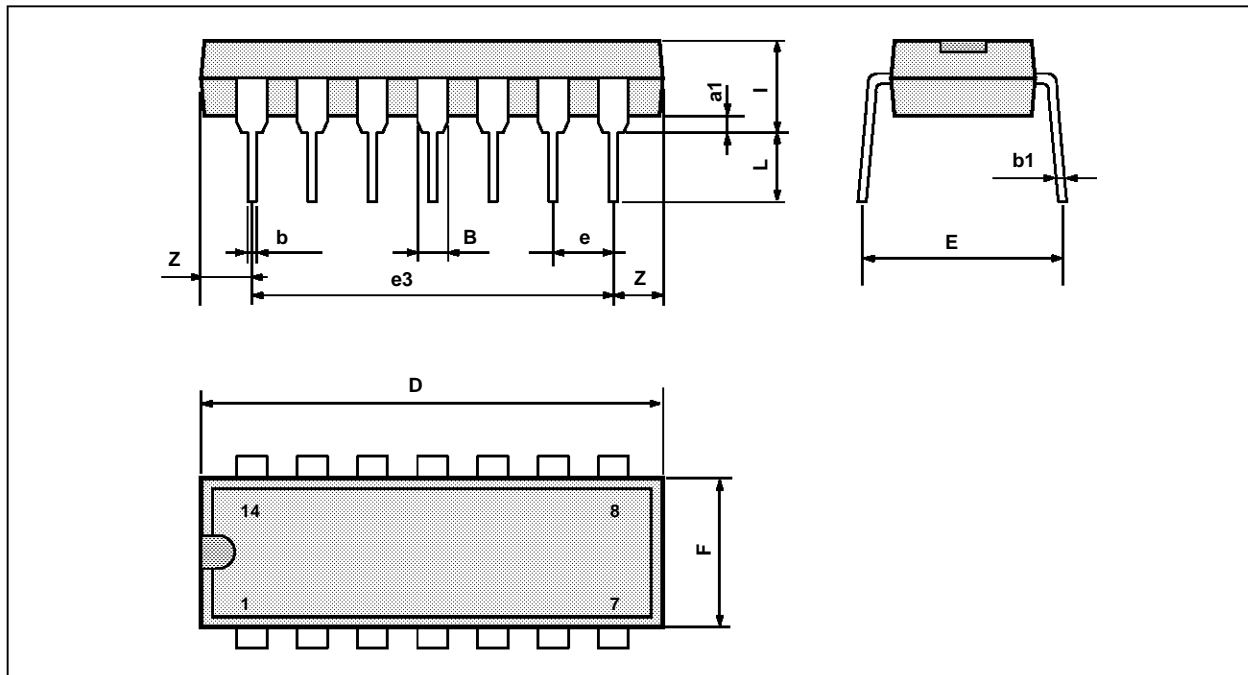

PM-DIP14.EPS

Dimensions	Millimeters			Inches		
	Min.	Typ.	Max.	Min.	Typ.	Max.
a1	0.51			0.020		
B	1.39		1.65	0.055		0.065
b		0.5			0.020	
b1		0.25			0.010	
D			20			0.787
E		8.5			0.335	
e		2.54			0.100	
e3		15.24			0.600	
F			7.1			0.280
i			5.1			0.201
L		3.3			0.130	
Z	1.27		2.54	0.050		0.100

DIP14.TBL

Information furnished is believed to be accurate and reliable. However, SGS-THOMSON Microelectronics assumes no responsibility for the consequences of use of such information nor for any infringement of patents or other rights of third parties which may result from its use. No licence is granted by implication or otherwise under any patent or patent rights of SGS-THOMSON Microelectronics. Specifications mentioned in this publication are subject to change without notice. This publication supersedes and replaces all information previously supplied. SGS-THOMSON Microelectronics products are not authorized for use as critical components in life support devices or systems without express written approval of SGS-THOMSON Microelectronics.

© 1994 SGS-THOMSON Microelectronics - All Rights Reserved

Purchase of I²C Components of SGS-THOMSON Microelectronics, conveys a license under the Philips I²C Patent. Rights to use these components in a I²C system, is granted provided that the system conforms to the I²C Standard Specifications as defined by Philips.

SGS-THOMSON Microelectronics GROUP OF COMPANIES

Australia - Brazil - China - France - Germany - Hong Kong - Italy - Japan - Korea - Malaysia - Malta - Morocco
The Netherlands - Singapore - Spain - Sweden - Switzerland - Taiwan - Thailand - United Kingdom - U.S.A.