

RGB HIGH VOLTAGE VIDEO AMPLIFIER

PRELIMINARY DATA

- BANDWIDTH : 10MHz TYPICAL
- RISE AND FALL TIME : 50ns TYPICAL
- CRT CATHODES CURRENT OUTPUTS FOR PARALLEL OR SEQUENTIAL CUT-OFF OR DRIVE ADJUSTMENT
- FLASHOVER PROTECTION
- POWER DISSIPATION : 3.5W
- ESD PROTECTED

DESCRIPTION

The TEA5101B includes three video amplifiers designed with a high voltage DMOS/bipolar technology. It drives directly the three CRT cathodes. The device is protected against flashovers. Due to its three cathode current outputs, the TEA5101B can be used with both parallel and sequential sampling applications.

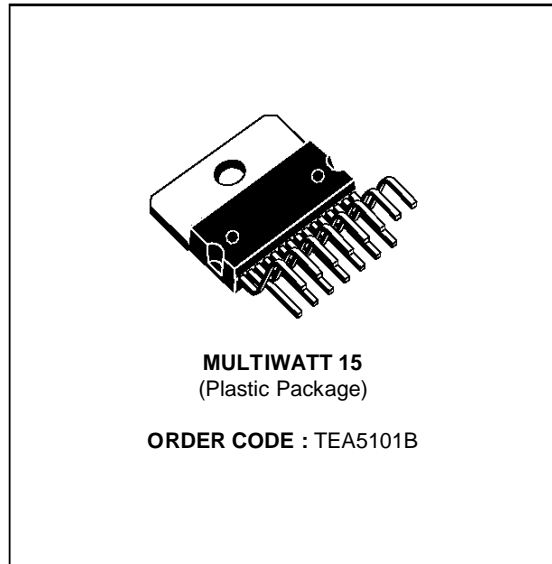

PIN CONNECTIONS (top view)

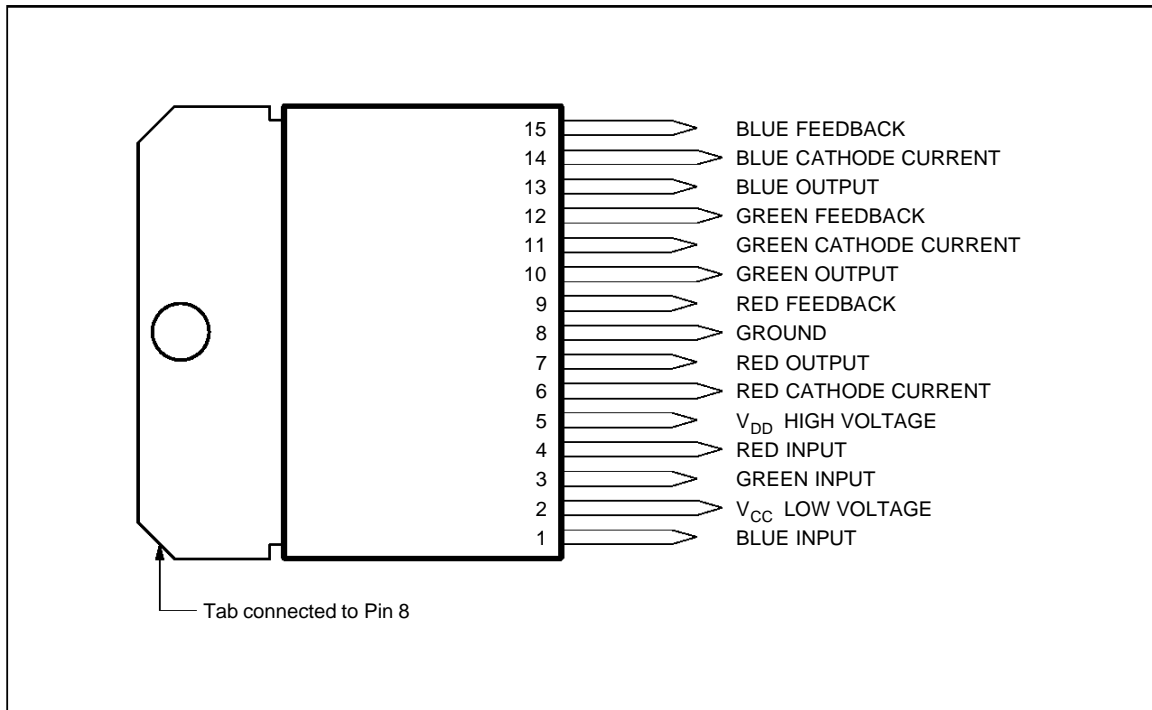

5101B-01.EPS

PIN FUNCTION

N°	Function	Description
1	Blue Input	Input of the "blue" amplifier. It is a virtual ground with 3.8V bias voltage, 15 microamperes input bias current with 14kΩ input resistance.
2	V _{CC}	Low voltage power supply, typically 12V.
3	Green Input	See Pin 1.
4	Red Input	See Pin 1.
5	V _{DD}	High voltage power supply, typically 200V.
6	Red Cathode Current	Provides the video processor with a copy of the DC current flowing into the red cathode, for automatic cut-off or gain adjustment. If this control is not used, Pin 6 must be grounded.
7	Red Output	Output driving the red cathode. Pin 7 is internally protected against CRT arc discharges by a diode limiting the output voltage to V _{DD} .
8	Ground	Also connected to the heatsink.
9	Red Feedback	Output driving the feedback resistor network for the red amplifier.
10	Green Output	See Pin 7.
11	Green Cathode Current	See Pin 6.
12	Green Feedback	See Pin 9.
13	Blue Output	See Pin 7.
14	Blue Cathode Current	See Pin 6.
15	Blue Feedback	See Pin 9.

5101B-01.TBL

BLOCK DIAGRAM OF EACH CHANNEL

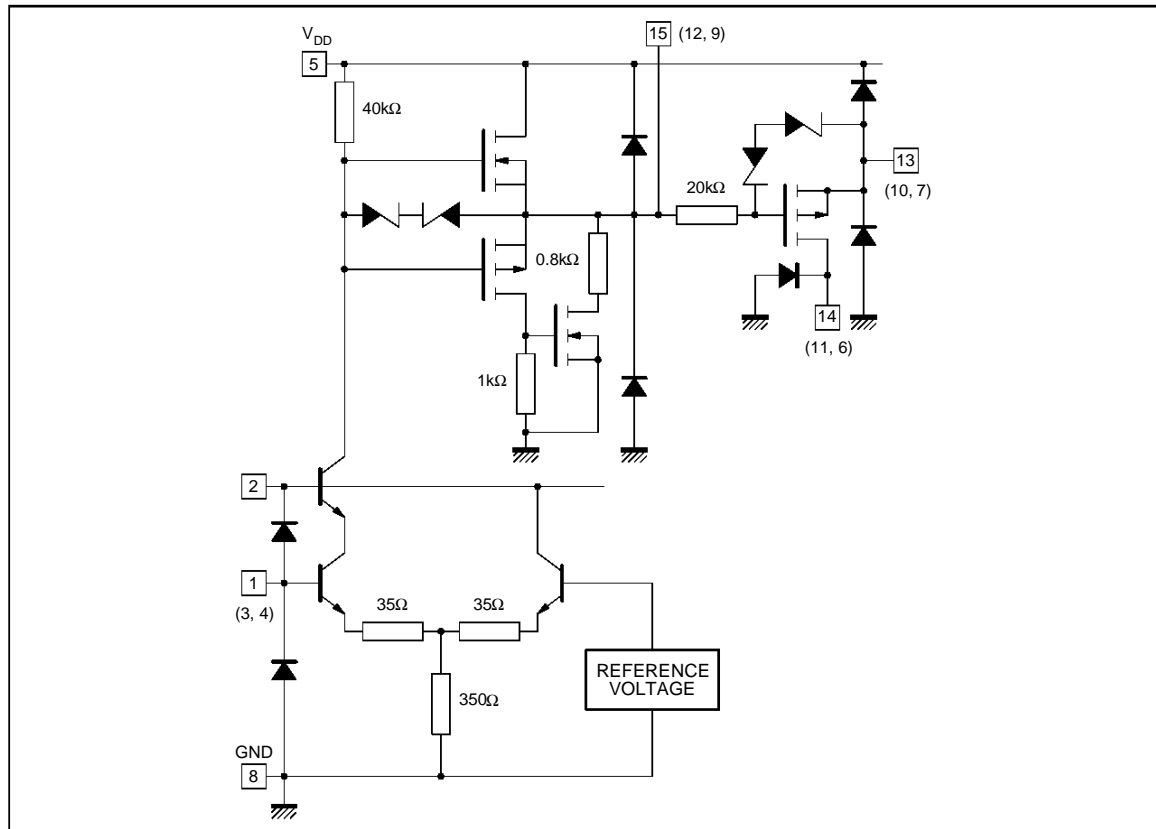

5101B-02.EPS

ABSOLUTE MAXIMUM RATINGS

Symbol	Parameter	Value	Unit
V _{DD}	Supply High Voltage Pin 5	250	V
V _{CC}	Supply Low Voltage Pin 2	20	V
I _O I _O	Output Current to V _{DD} to Ground Pins 7 - 10 - 13	Protected 8	mA
I _F I _F	Output Current to V _{DD} to Ground Pins 9 - 12 - 15	45 45	mA mA
I _j	Input Current Pins 1 - 3 - 4	60	mA
T _j	Junction Temperature	150	°C
T _{oper}	Operating Ambient Temperature	0 to 70	°C
T _{stg}	Storage Temperature	- 55 to + 150	°C

5101B-02.TBL

THERMAL DATA

Symbol	Parameter	Value	Unit
R _{th(j-c)}	Maximum Junction Case Thermal Resistance Max.	3	°C/W
R _{th(j-a)}	Typical Junction Ambient Thermal Resistance Typ.	35	°C/W

5101B-03.TBL

ELECTRICAL CHARACTERISTICS

T_{amb} = 25°C ; V_{CC} = 12V ; V_{DD} = 220V ; AV = 55 (unless otherwise specified)

Symbol	Parameter	Min.	Typ.	Max.	Unit
V _{DD}	High Supply Voltage Pin 5		200	220	V
V _{CC}	Low Supply Voltage Pin 2	10	12	15	V
I _{DD}	High Voltage Supply Internal DC Current (V _{out} 100V) (without the current due to the feedback network) Pin 5		9.5	15	mA
I _{CC}	Low Voltage Supply Internal DC Current		38	55	mA
V _{sath}	Output Saturation Voltage (High level) I _O = - 10 μA Pins 7-10-13		3	10	V
R _{ON}	Output Mos Transistor (Low level) R _{ON} @ I _O = 3 mA Pins 7-10-13		1.7		kΩ
BW	Bandwidth (- 3db) (measured on CRT cathodes) (C _{LOAD} : 10pF - R Protect = 1kΩ - V _{out} = 100V) Δ V _{out} : 50 V _{PP} Δ V _{out} : 100 V _{PP}		10 8		MHz MHz
T _R - T _F	Rise Time and Fall Time : measured between 10% and 90% of output pulse (C _{LOAD} : 10 pF - R Protect = 1 kΩ - V _{out} = 100 V) Δ V _{out} : 100 V _{PP}		50		ns
G _O	Open Loop Gain	47	53		dB
	Open Loop Gain Difference between 2 channels	-1.5	0	+1.5	dB
	Open Loop Gain Temperature Coefficient		0		dB/°C
P	Internal Power Dissipation (see calculation below)		3.5		W
V _{REF}	Internal Voltage Reference Pins 1-3-4	3.55	3.85	4.15	V
	Internal Reference Voltage Difference Between 2 Channels			250	mV
	Voltage Reference Temperature Coefficient		0		mV/°C
I _{IB}	Input Bias Current (V _{out} : 100 V) Pins 1-3-4		15		μA
R _I	Input Resistance		14		kΩ

5101B-04.TBL

TYPICAL APPLICATION

The TEA5101B consists of three independent amplifiers. Each of them includes :

- A differential amplifier, the gain of which is fixed by external feedback resistors,
- A voltage reference,
- A PMOS transistor providing a copy of the cathode current,
- A protection diode against CRT arc discharges.

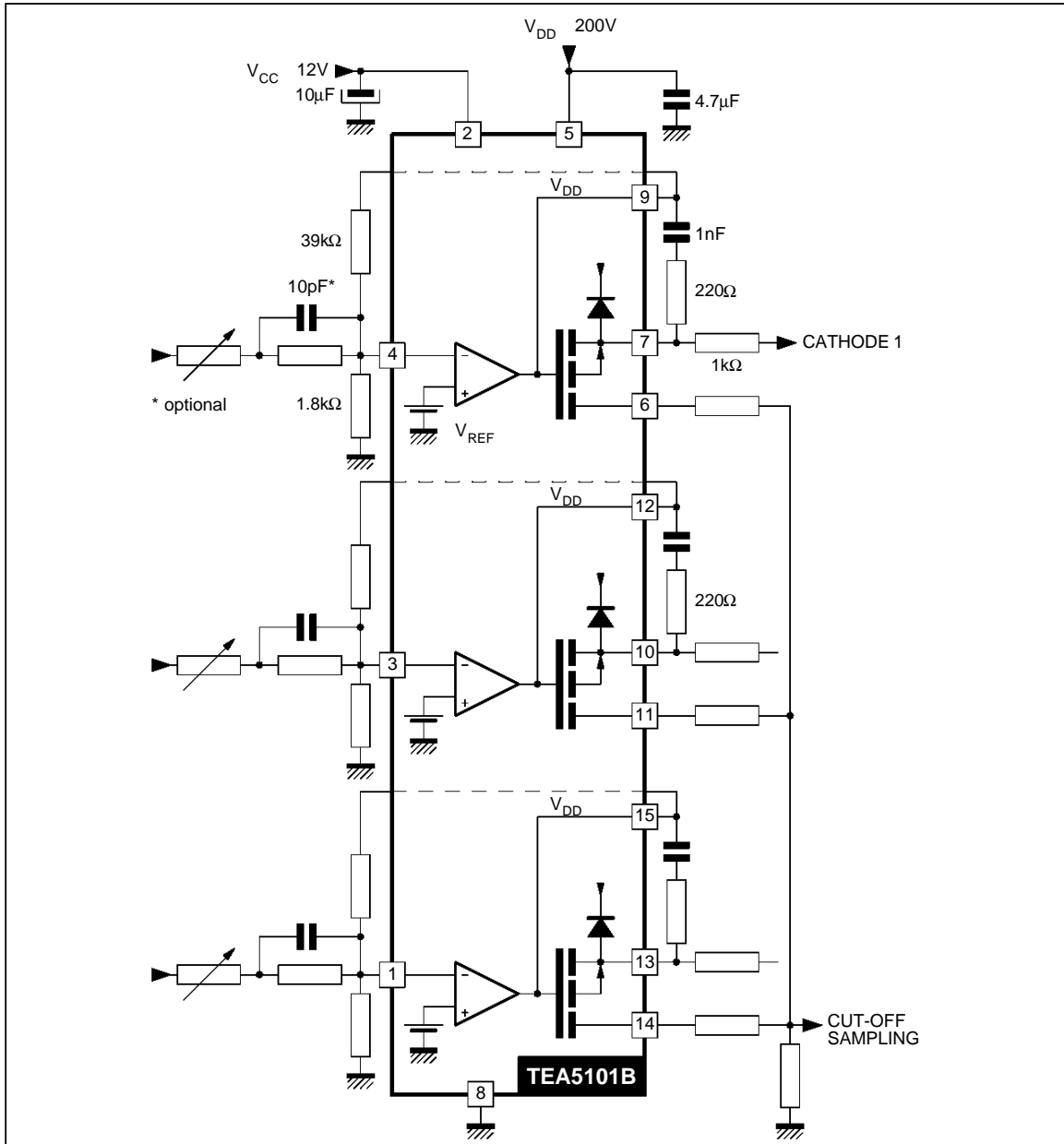

5101B-03.EPS

APPLICATION INFORMATION

PC BOARD LAYOUT

The best performances of the high voltage video amplifier will be obtained only with a carefully designed PC board. Output to input capacitances are of particular importance.

For a single amplifier, the input-output capacitance, in parallel with the relatively high feedback resistance, creates a pole in the closed-loop transfer function. A low parasitic capacitance (0.3pF) feedback resistor and HF isolated printed wires are necessary. Further more, capacitive coupling from the output of an amplifier toward the input of another one may induce excessive crosstalk.

POWER DISSIPATION

The power dissipation consists of a static part and a dynamic part. The static dissipation varies with the output voltage. With $V_{DD} = 200V$, $P_{stat} = 2.6W$ typ (3.5W max) at $V_{OUT} = 100V$, 1.5W typ at 150V and 3W typ at 50V (with R feedback = 39k Ω).

V_{OUT} first value (100V) will be the reference.

The dynamic dissipation depends on the signal spectrum and the load capacitance.

- Dynamic power with a typical picture with 150 V_{pp} modulation is typically 1W.
- For a sine wave, dynamic dissipation per amplifier is $P_d = F \times C_l \times V_{opp} \times V_{dd} \times 0.8$.

The load capacitance C_L includes CRT and board capacitance (10pF), and amplifier output capacitance (8pF) : total C_L value is about 20pF. For a 5MHZ, 50 V_{pp} sine wave and a 20pF load capacitance, the maximum dynamic power is 2.5W.

- Generally, the maximum dynamic power is reached with a white noise (tuner noise).
- Typical value is about 2W.

Total dissipation is typically 3.6W (2.6W + 1W). With a maximum static dissipation of 3.5W, total dissipation is :

- 4.5W with a typical picture (UER pattern)
- 5.5W with white noise

TEA5101B

PACKAGE MECHANICAL DATA : 15 PINS – PLASTIC MULTIWATT

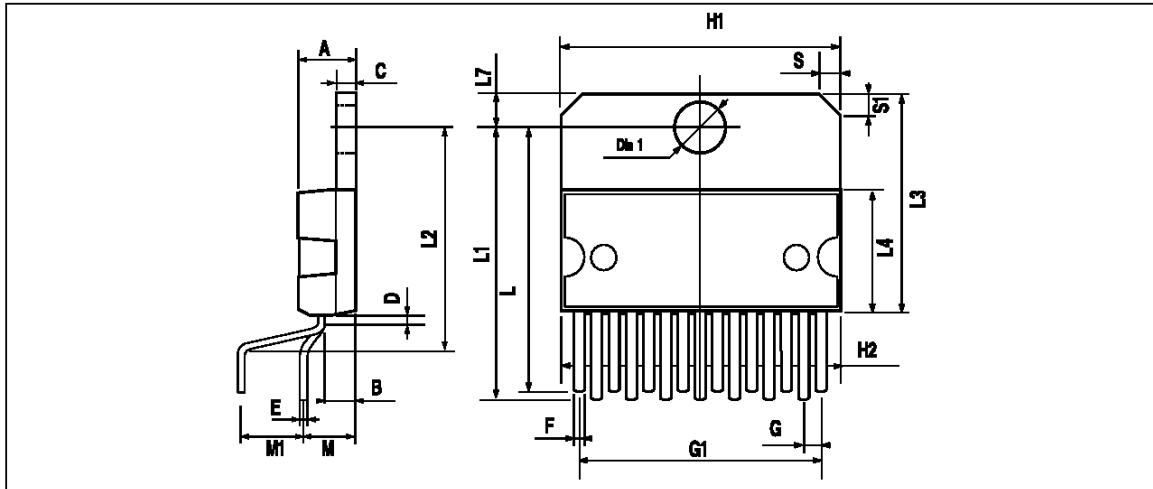

PM-MW15V/EP5

Dimensions	Millimeters			Inches		
	Min.	Typ.	Max.	Min.	Typ.	Max.
A			5			0.197
B			2.65			0.104
C			1.6			0.063
D		1			0.039	
E	0.49		0.55	0.019		0.022
F	0.66		0.75	0.026		0.030
G	1.02	1.27	1.52	0.040	0.050	0.060
G1	17.53	17.78	18.03	0.690	0.700	0.710
H1	19.6			0.772		
H2			20.2			0.795
L	21.9	22.2	22.5	0.862	0.874	0.886
L1	21.7	22.1	22.5	0.854	0.870	0.886
L2	17.65		18.1	0.695		0.713
L3	17.25	17.5	17.75	0.679	0.689	0.699
L4	10.3	10.7	10.9	0.406	0.421	0.429
L7	2.65		2.9	0.104		0.114
M	4.25	4.55	4.85	0.167	0.179	0.191
M1	4.63	5.08	5.53	0.182	0.200	0.218
S	1.9		2.6	0.075		0.102
S1	1.9		2.6	0.075		0.102
Dia. 1	3.65		3.85	0.144		0.152

MW15V.TBL

Information furnished is believed to be accurate and reliable. However, SGS-THOMSON Microelectronics assumes no responsibility for the consequences of use of such information nor for any infringement of patents or other rights of third parties which may result from its use. No licence is granted by implication or otherwise under any patent or patent rights of SGS-THOMSON Microelectronics. Specifications mentioned in this publication are subject to change without notice. This publication supersedes and replaces all information previously supplied. SGS-THOMSON Microelectronics products are not authorized for use as critical components in life support devices or systems without express written approval of SGS-THOMSON Microelectronics.

© 1996 SGS-THOMSON Microelectronics - All Rights Reserved

Purchase of μ C Components of SGS-THOMSON Microelectronics, conveys a license under the Philips μ C Patent. Rights to use these components in a μ C system, is granted provided that the system conforms to the μ C Standard Specifications as defined by Philips.

SGS-THOMSON Microelectronics GROUP OF COMPANIES

Australia - Brazil - Canada - China - France - Germany - Hong Kong - Italy - Japan - Korea - Malaysia - Malta - Morocco
The Netherlands - Singapore - Spain - Sweden - Switzerland - Taiwan - Thailand - United Kingdom - U.S.A.