

**RGB SWITCHING CIRCUIT**

- 25MHz BANDWIDTH
- CROSSTALK : 55dB
- SHORT CIRCUIT TO GROUND OR  $V_{CC}$  PROTECTED
- ANTI SATURATION GAIN CHANGING
- VIDEO SWITCHING

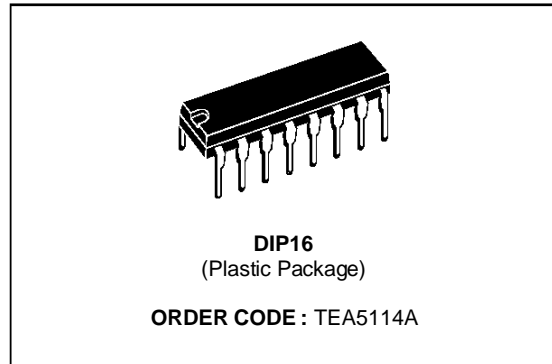

**DESCRIPTION**

This integrated circuit provides RGB switching allowing connections between peri TV plug, internal RGB generator and video processor in a TV set.

The input signal black level is tied to the same reference voltage on each input in order to have no differential voltage when switching two RGB generators.

An AC output signal higher than 2 Vpp makes gain going slowly down to 0dB to protect the TV set video amplifier from saturation.

Fast blanking output is a logical OR between FB1 (Pin 8) and FB2 (Pin 10).

**PIN CONNECTIONS**

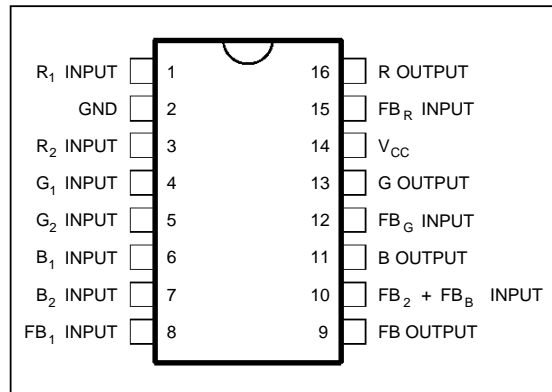

5114A-01.EPS

**BLOCK DIAGRAM**

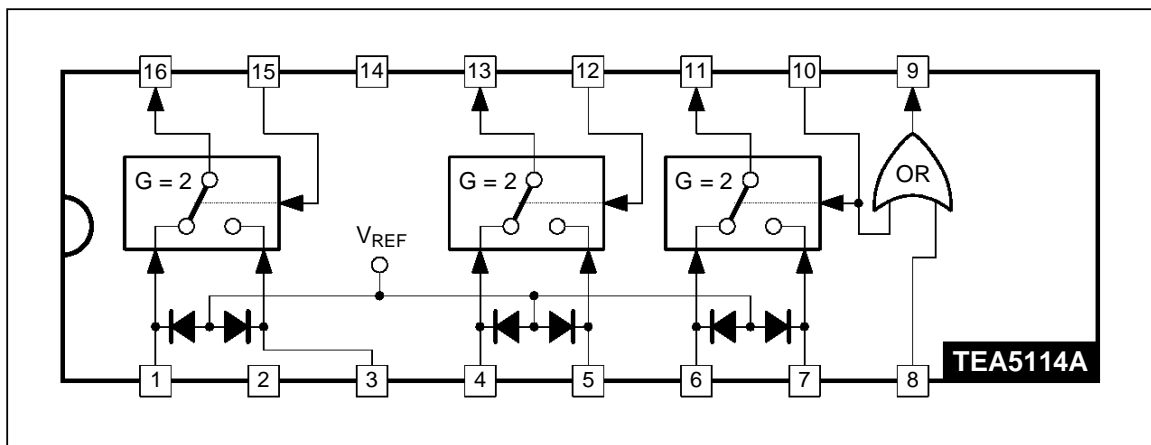

5114A-02.EPS

## ABSOLUTE MAXIMUM RATINGS

Symbol	Parameter	Value	Unit
V <sub>CC</sub>	Supply Voltage	18	V
T <sub>j</sub>	Junction Temperature	- 40 to 150	°C
T <sub>stg</sub>	Storage Temperature	- 40 to 150	°C
Z <sub>L</sub>	Minimum Load Resistor on Each Output V <sub>CC</sub> = 12 V V <sub>CC</sub> = 10 V	300 150	Ω
T <sub>amb</sub>	Operating Ambient Temperature	0 to 70	°C

5114A-01.TBL

## THERMAL DATA

Symbol	Parameter	Value	Unit
R <sub>th(j-a)</sub>	Junction-ambient Thermal Resistance	80	°C/W

5114A-02.TBL

## ELECTRICAL OPERATING CHARACTERISTICS

T<sub>amb</sub> = 25 °C, V<sub>CC</sub> = 12 V, Z<sub>L</sub> (RGB) = 300 ΩV<sub>CC</sub> = 10 V, Z<sub>L</sub> (RGB) = 150 Ω (unless otherwise specified)

Symbol	Parameter	Min.	Typ.	Max.	Unit
V <sub>CC</sub>	Supply Voltage	9	12	13.2	V
I <sub>CC</sub>	Supply Current without Load V <sub>CC</sub> = 12 V	20	30	40	mA
V <sub>ON</sub>	Black Level Output Voltage (on pins 11, 13, 16 square wave output signal 1 kHz - 1 V <sub>pp</sub> ) T <sub>j</sub> = 25 °C (5mV/°C typical variation)	1.8	2.5	2.9	V
G <sub>RGB</sub>	Gain of Each Channel Pins 11, 13, 16 F = 1 MHz, V <sub>in</sub> = 0.5 V <sub>pp</sub>	5	5.5	6	dB
B <sub>RGB</sub>	Bandwidth (- 3 dB) V <sub>O</sub> = 1 V <sub>pp</sub>	18	22		MHz
V <sub>GC</sub>	Threshold Output Voltage for Gain Changing (- 0.5 dB)	2			V <sub>pp</sub>
V <sub>R</sub>	Video Rejection between Two Inputs R, G or B F = 1 MHz Sinus V <sub>O</sub> = 1 V <sub>pp</sub>	50	55		dB
Z <sub>IRGB</sub>	Input Impedance on Pins 1, 3, 4, 5, 6, 7 V <sub>O</sub> = 1 V <sub>pp</sub>	10			kΩ
Z <sub>ORGB</sub>	R, G, B Output Impedance on Pins 11, 13, 16			15	Ω
T <sub>FB</sub>	FB rising and falling time on pin 9. 1 V <sub>pp</sub> Input Voltage Pins 8, 10		20		ns
V <sub>IHF</sub>	FB High Level Input Voltage on Pins 8, 10, 12, 15	1		4	V
V <sub>ILFB</sub>	FB Low Level Input Voltage on Pins 8, 10, 12, 15	0		0.4	V
Z <sub>IFB</sub>	Input Impedance on Pins 8, 10, 12, 15	0.7	1	1.3	kΩ
V <sub>OHF</sub>	High Level FB Output Voltage (pin 9) Input 1 V on Pins 8, 10	0.8	1	1.2	V
V <sub>OLFB</sub>	Low Level FB Output (pin 9) Input 0 V on Pins 8, 10			0.3	V
Z <sub>OFB</sub>	FB Output Impedance Pin 9 High Level			30	Ω
T <sub>dFBRGB</sub>	Delay Time between FB Inputs and R, G, B Switching		20		ns

5114A-03.TBL

TEST DIAGRAM

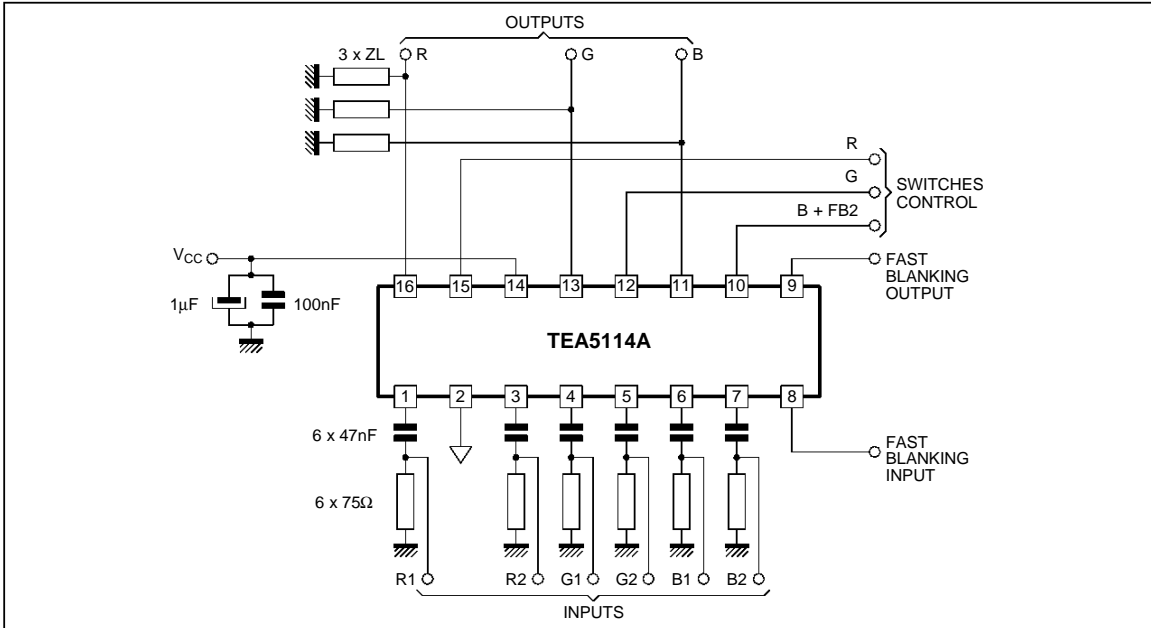

5114A-03.EPS

TYPICAL R, G, B SWITCHING APPLICATION

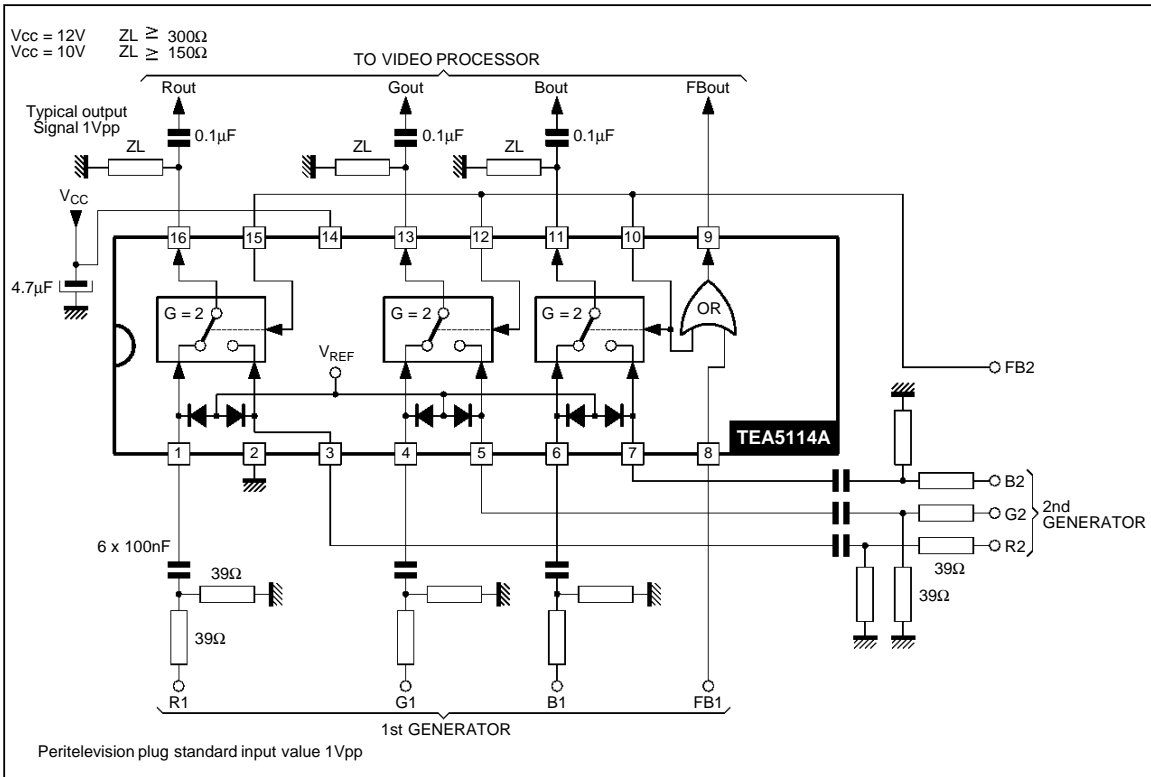

Peritelevision plug standard input value 1Vpp

5114A-04.EPS

**PACKAGE MECHANICAL DATA**  
16 PINS – PLASTIC DIP

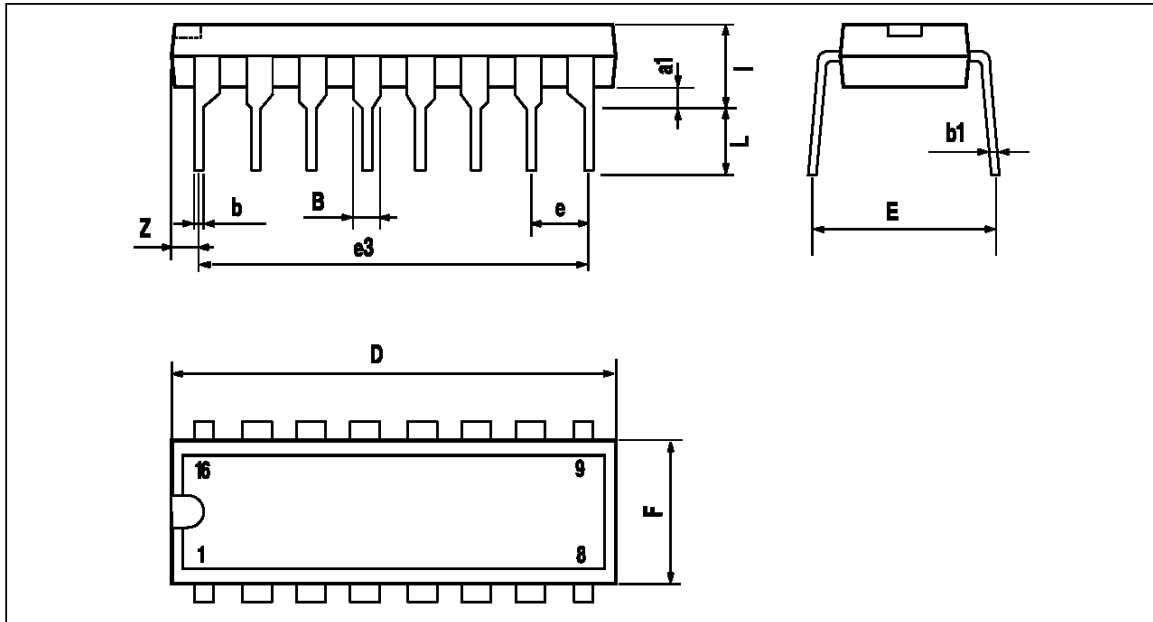

PM-DIP16.EPS

Dimensions	Millimeters			Inches		
	Min.	Typ.	Max.	Min.	Typ.	Max.
a1	0.51			0.020		
B	0.77		1.65	0.030		0.065
b		0.5			0.020	
b1		0.25			0.010	
D			20			0.787
E		8.5			0.335	
e		2.54			0.100	
e3		17.78			0.700	
F			7.1			0.280
l			5.1			0.201
L		3.3			0.130	
Z			1.27			0.050

DIP16.TBL

Information furnished is believed to be accurate and reliable. However, SGS-THOMSON Microelectronics assumes no responsibility for the consequences of use of such information nor for any infringement of patents or other rights of third parties which may result from its use. No licence is granted by implication or otherwise under any patent or patent rights of SGS-THOMSON Microelectronics. Specifications mentioned in this publication are subject to change without notice. This publication supersedes and replaces all information previously supplied. SGS-THOMSON Microelectronics products are not authorized for use as critical components in life support devices or systems without express written approval of SGS-THOMSON Microelectronics.

© 1996 SGS-THOMSON Microelectronics - All Rights Reserved

Purchase of I<sup>2</sup>C Components of SGS-THOMSON Microelectronics, conveys a license under the Philips I<sup>2</sup>C Patent. Rights to use these components in a I<sup>2</sup>C system, is granted provided that the system conforms to the I<sup>2</sup>C Standard Specifications as defined by Philips.

SGS-THOMSON Microelectronics GROUP OF COMPANIES

Australia - Brazil - Canada - China - France - Germany - Hong Kong - Italy - Japan - Korea - Malaysia - Malta - Morocco  
The Netherlands - Singapore - Spain - Sweden - Switzerland - Taiwan - Thailand - United Kingdom - U.S.A.