

MC1488, SN55188, SN75188 QUADRUPLE LINE DRIVERS

SLLS094C – SEPTEMBER 1983 – REVISED MAY 2004

- Meet or Exceed the Requirements of ANSI TIA/EIA-232-E and ITU Recommendation V.28
- Current-Limited Output: 10 mA Typical
- Power-Off Output Impedance: 300 Ω Minimum
- Slew Rate Control by Load Capacitor
- Flexible Supply-Voltage Range
- Input Compatible With Most TTL Circuits

description/ordering information

The MC1488, SN55188, and SN75188 are monolithic quadruple line drivers designed to interface data terminal equipment with data communications equipment in conformance with ANSI TIA/EIA-232-E, using a diode in series with each supply-voltage terminal as shown under typical applications.

The SN55188 is characterized for operation over the full military temperature range of -55°C to 125°C . The MC1488 and SN75188 are characterized for operation from 0°C to 70°C .

SN55188 . . . J OR W PACKAGE
SN75188 . . . D, N, OR NS PACKAGE
MC1488 . . . N PACKAGE
(TOP VIEW)

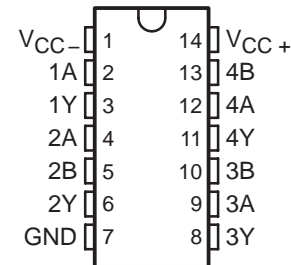

SN55188 . . . FK PACKAGE
(TOP VIEW)

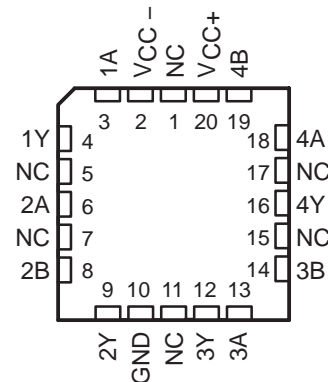

NC – No internal connection

ORDERING INFORMATION

T _A	PACKAGE†		ORDERABLE PART NUMBER	TOP-SIDE MARKING
0°C to 70°C	PDIP (N)	Tube of 25	MC1488N	MC1488N
		Tube of 25	SN75188N	SN75188N
	SOIC (D)	Tube of 50	SN75188D	SN75188
		Reel of 2500	SN75188DR	
	SOP (NS)	Reel of 2000	SN75188NSR	SN75188
-55°C to 125°C	CDIP (J)	Tube of 25	SN55188J	SN55188J
			SNJ55188J	SNJ55188J
	CFP (W)	Tube of 150	SNJ55188W	SNJ55188W
	LCCC (FK)	Tube of 55	SNJ55188FK	SNJ55188FK

† Package drawings, standard packing quantities, thermal data, symbolization, and PCB design guidelines are available at www.ti.com/sc/package.



Please be aware that an important notice concerning availability, standard warranty, and use in critical applications of Texas Instruments semiconductor products and disclaimers thereto appears at the end of this data sheet.

PRODUCTION DATA information is current as of publication date. Products conform to specifications per the terms of Texas Instruments standard warranty. Production processing does not necessarily include testing of all parameters.

 **TEXAS
INSTRUMENTS**

POST OFFICE BOX 655303 • DALLAS, TEXAS 75265

Copyright © 2004, Texas Instruments Incorporated
On products compliant to MIL-PRF-38535, all parameters are tested unless otherwise noted. On all other products, production processing does not necessarily include testing of all parameters.

MC1488, SN55188, SN75188 QUADRUPLE LINE DRIVERS

SLLS094C – SEPTEMBER 1983 – REVISED MAY 2004

FUNCTION TABLE
(drivers 2–4)

A	B	Y
H	H	L
L	X	H
X	L	H

H = high level, L = low level,
X = irrelevant

logic diagram (positive logic)

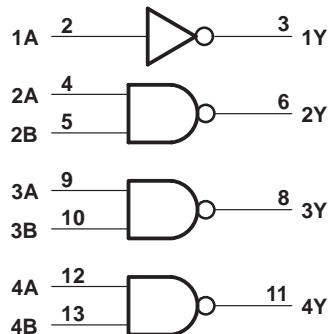

Positive logic
 $Y = \overline{A}$ (driver 1)
 $Y = AB$ or $\overline{A} + \overline{B}$ (drivers 2 thru 4)

schematic (each driver)

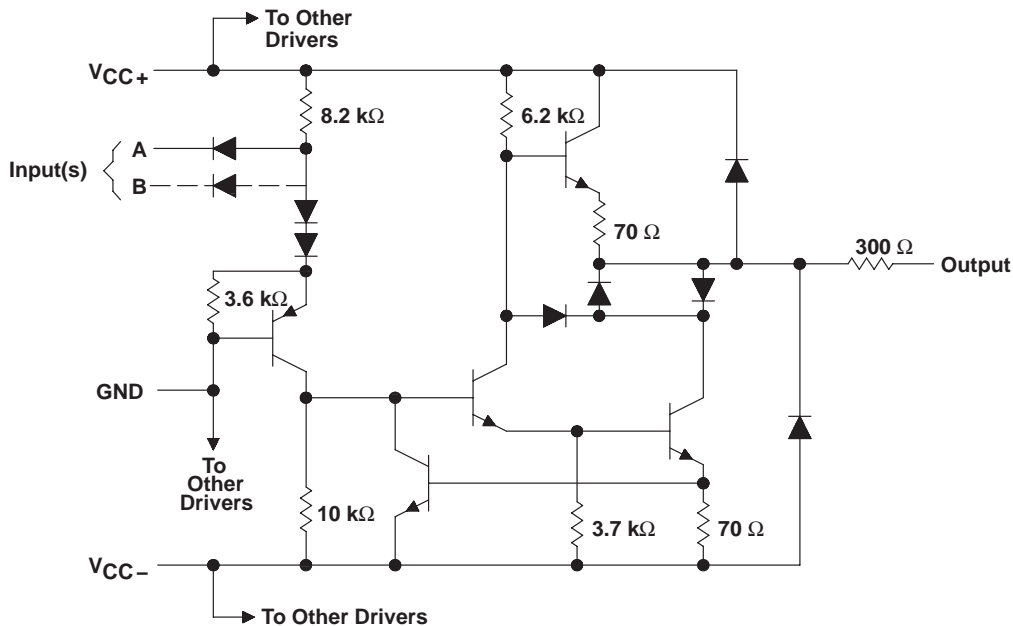

Resistor values shown are nominal.

absolute maximum ratings over operating free-air temperature (unless otherwise noted)†

Supply voltage, V_{CC+} at (or below) 25°C free-air temperature (see Notes 1 and 2)	15 V
Supply voltage, V_{CC-} at (or below) 25°C free-air temperature (see Notes 1 and 2)	–15 V
Input voltage, V_I	–15 V to 7 V
Output voltage, V_O	–15 V to 15 V
Continuous total power dissipation (see Note 2)	See Dissipation Rating Table
Package thermal impedance, θ_{JA} (see Notes 3 and 4): D package	86°C/W
N package	80°C/W
NS package	76°C/W
Operating virtual junction temperature, T_J	150°C
Case temperature for 60 seconds, FK package	260°C
Lead temperature 1,6 mm (1/16 inch) from case for 60 seconds: J or W package	300°C
Storage temperature range, T_{stg}	–65°C to 150°C

† Stresses beyond those listed under “absolute maximum ratings” may cause permanent damage to the device. These are stress ratings only, and functional operation of the device at these or any other conditions beyond those indicated under “recommended operating conditions” is not implied. Exposure to absolute-maximum-rated conditions for extended periods may affect device reliability.

- NOTES:
1. All voltage values are with respect to the network ground terminal.
 2. For operation above 25°C free-air temperature, refer to the maximum supply voltage curve, Figure 6. In the J package, SN55188 chips are alloy mounted.
 3. Maximum power dissipation is a function of $T_{J(max)}$, θ_{JA} , and T_A . The maximum allowable power dissipation at any allowable ambient temperature is $P_D = (T_{J(max)} - T_A)/\theta_{JA}$. Selecting the maximum of 150°C can affect reliability.
 4. The package thermal impedance is calculated in accordance with JESD 51-7.

DISSIPATION RATING TABLE

PACKAGE	$T_A \leq 25^\circ\text{C}$ POWER RATING	DERATING FACTOR ABOVE $T_A = 25^\circ\text{C}$	$T_A = 70^\circ\text{C}$ POWER RATING	$T_A = 125^\circ\text{C}$ POWER RATING
FK	1375 mW	11.0 mW/°C	880 mW	275 mW
J	1375 mW	11.0 mW/°C	880 mW	275 mW
W	1000 mW	8.0 mW/°C	640 mW	200 mW

recommended operating conditions

		SN55188			MC1488, SN75188			UNIT
		MIN	NOM	MAX	MIN	NOM	MAX	
V_{CC+}	Supply voltage	7.5	9	15	7.5	9	15	V
V_{CC-}	Supply voltage	–7.5	–9	–15	–7.5	–9	–15	V
V_{IH}	High-level input voltage	1.9			1.9			V
V_{IL}	Low-level input voltage			0.8			0.8	V
T_A	Operating free-air temperature	–55		125	0		70	°C

MC1488, SN55188, SN75188 QUADRUPLE LINE DRIVERS

SLLS094C – SEPTEMBER 1983 – REVISED MAY 2004

electrical characteristics over operating free-air temperature range, $V_{CC\pm} = \pm 9\text{ V}$ (unless otherwise noted)

PARAMETER	TEST CONDITIONS		SN55188			MC1488, SN75188			UNIT
			MIN	TYP†	MAX	MIN	TYP†	MAX	
V_{OH} High-level output voltage	$V_{IL} = 0.8\text{ V}$, $R_L = 3\text{ k}\Omega$	$V_{CC+} = 9\text{ V}$, $V_{CC-} = -9\text{ V}$	6	7		6	7		V
		$V_{CC+} = 13.2\text{ V}$, $V_{CC-} = -13.2\text{ V}$	9	10.5		9	10.5		
V_{OL} Low-level output voltage	$V_{IH} = 1.9\text{ V}$, $R_L = 3\text{ k}\Omega$	$V_{CC+} = 9\text{ V}$, $V_{CC-} = -9\text{ V}$		-7‡	-6		-7	-6	V
		$V_{CC+} = 13.2\text{ V}$, $V_{CC-} = -13.2\text{ V}$		-10.5‡	-9		-10.5	-9	
I_{IH} High-level input current	$V_I = 5\text{ V}$				10			10	μA
I_{IL} Low-level input current	$V_I = 0$			-1	-1.6		-1	-1.6	mA
$I_{OS(H)}$ Short-circuit output current at high level§	$V_I = 0.8\text{ V}$	$V_O = 0$	-4.6	-9	-13.5	-6	-9	-12	mA
$I_{OS(L)}$ Short-circuit output current at low level§	$V_I = 1.9\text{ V}$	$V_O = 0$	4.6	9	13.5	6	9	12	mA
r_o Output resistance, power off	$V_{CC+} = 0$, $V_{CC-} = 0$, $V_O = -2\text{ V to } 2\text{ V}$		300			300			Ω
I_{CC+} Supply current from V_{CC+}	$V_{CC+} = 9\text{ V}$, No load	All inputs at 1.9 V	15		20	15		20	mA
		All inputs at 0.8 V	4.5		6	4.5		6	
	$V_{CC+} = 12\text{ V}$, No load	All inputs at 1.9 V	19		25	19		25	
		All inputs at 0.8 V	5.5		7	5.5		7	
	$V_{CC+} = 15\text{ V}$, No load, $T_A = 25^\circ\text{C}$	All inputs at 1.9 V			34			34	
		All inputs at 0.8 V			12			12	
I_{CC-} Supply current from I_{CC-}	$V_{CC-} = -9\text{ V}$, No load	All inputs at 1.9 V	-13		-17	-13		-17	mA
		All inputs at 0.8 V			-0.5			-0.015	
	$V_{CC-} = -12\text{ V}$, No load	All inputs at 1.9 V	-18		-23	-18		-23	
		All inputs at 0.8 V			-0.5			-0.015	
	$V_{CC-} = -15\text{ V}$, No load, $T_A = 25^\circ\text{C}$	All inputs at 1.9 V			-34			-34	
		All inputs at 0.8 V			-2.5			-2.5	
P_D Total power dissipation	$V_{CC+} = 9\text{ V}$, No load		$V_{CC-} = -9\text{ V}$			333			mW
	$V_{CC+} = 12\text{ V}$, No load		$V_{CC-} = -12\text{ V}$			576			

† All typical values are at $T_A = 25^\circ\text{C}$.

‡ The algebraic convention, in which the less positive (more negative) limit is designated as minimum, is used in this data sheet for logic voltage levels only, e.g., if -6 V is a maximum, the typical value is a more negative voltage.

§ Not more than one output should be shorted at a time.



switching characteristics, $V_{CC\pm} = \pm 9\text{ V}$, $T_A = 25^\circ\text{C}$

PARAMETER	TEST CONDITIONS	MIN	TYP	MAX	UNIT
t_{PLH} Propagation delay time, low- to high-level output	$R_L = 3\text{ k}\Omega$, See Figure 1 $C_L = 15\text{ pF}$		220	350	ns
t_{PHL} Propagation delay time, high- to low-level output			100	175	ns
t_{TLH} Transition time, low- to high-level output†			55	100	ns
t_{THL} Transition time, high- to low-level output†			45	75	ns
t_{TLH} Transition time, low- to high-level output‡	$R_L = 3\text{ k}\Omega$ to $7\text{ k}\Omega$, See Figure 1 $C_L = 2500\text{ pF}$		2.5		μs
t_{THL} Transition time, high- to low-level output‡			3.0		μs

† Measured between 10% and 90% points of output waveform

‡ Measured between 3 V and -3 V points on the output waveform (TIA/EIA-232-E conditions)

PARAMETER MEASUREMENT INFORMATION

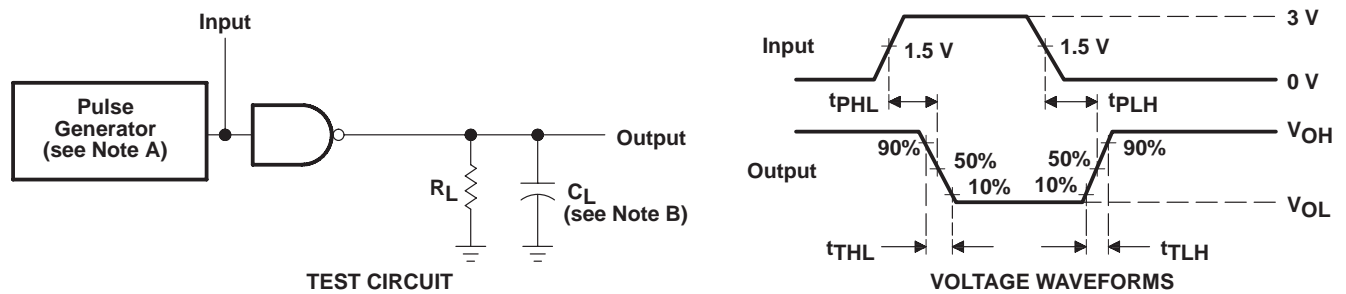

- NOTES: A. The pulse generator has the following characteristics: $t_w = 0.5\ \mu\text{s}$, $\text{PRR} \leq 1\ \text{MHz}$, $Z_O = 50\ \Omega$.
B. C_L includes probe and jig capacitance.

Figure 1. Test Circuit and Voltage Waveforms

TYPICAL CHARACTERISTICS†

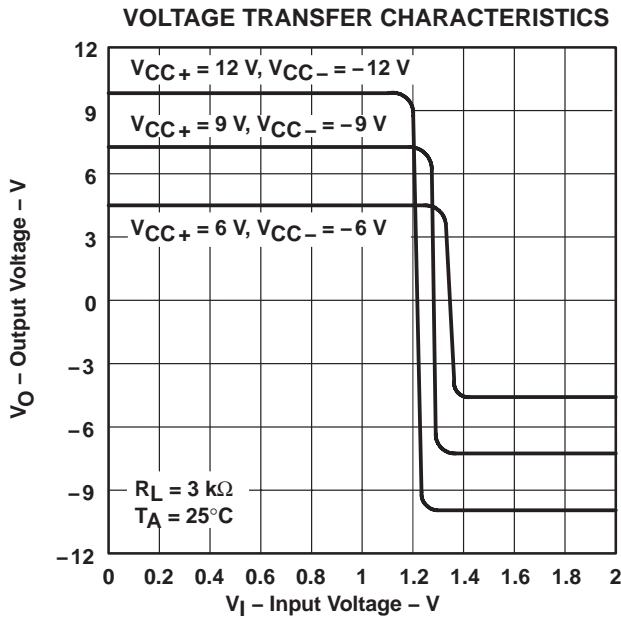

Figure 2

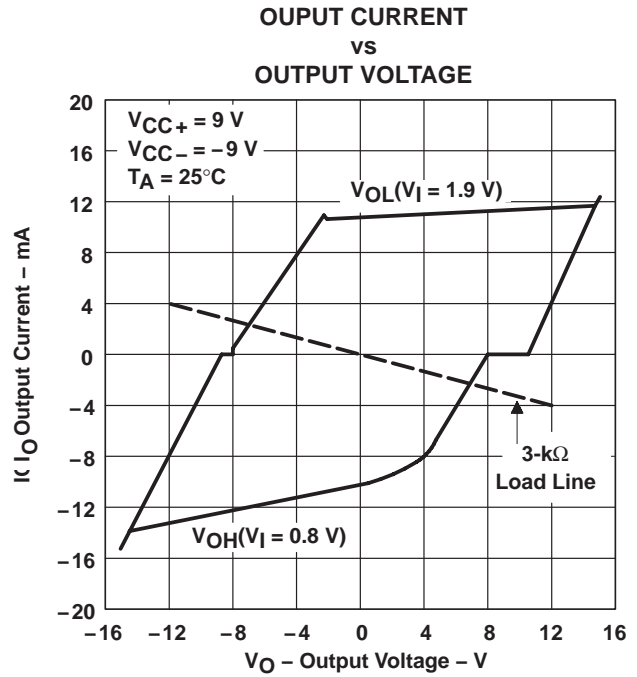

Figure 3

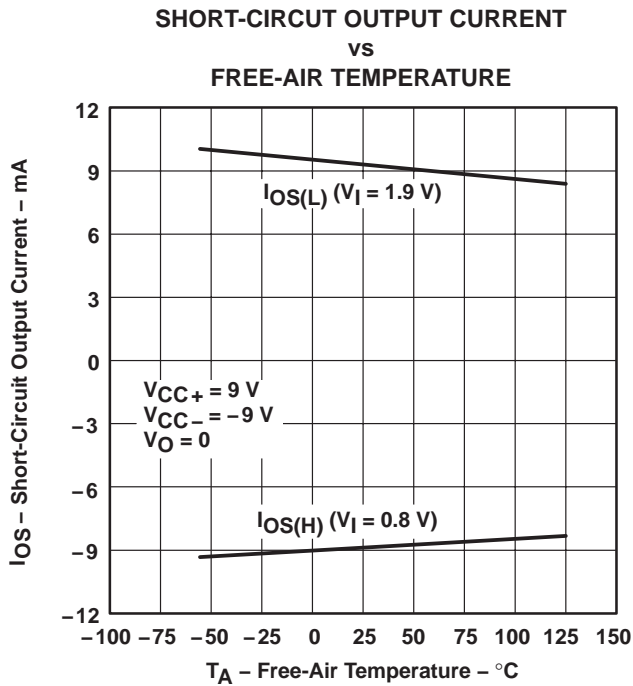

Figure 4

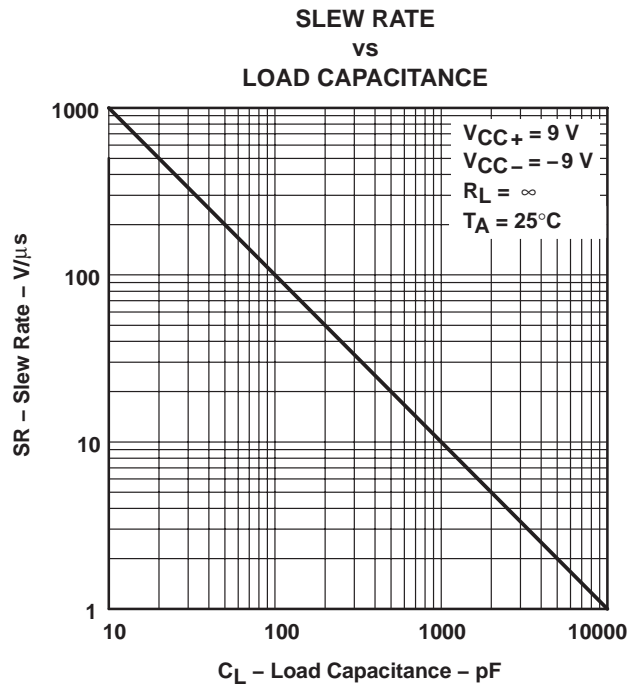

Figure 5

† Data for temperatures below 0°C and above 70°C are applicable to SN55188 circuit only.

THERMAL INFORMATION†

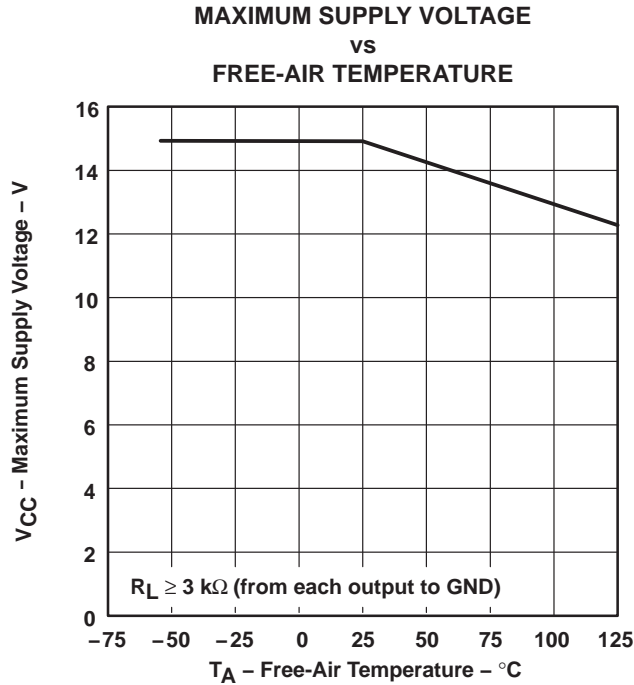

Figure 6

† Data for temperatures below 0°C and above 70°C are applicable to the SN55188 circuit only.

APPLICATION INFORMATION

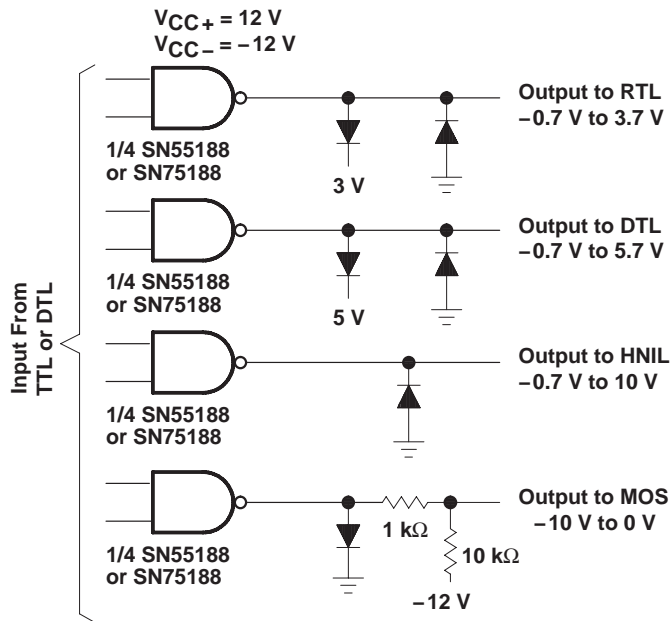
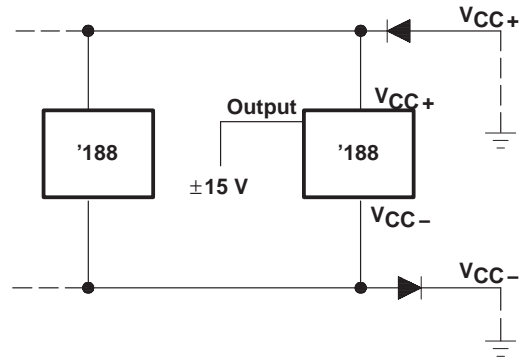

Figure 7. Logic Translator Applications



Diodes placed in series with the V_{CC+} and V_{CC-} leads protect the SN55188/SN75188 in the fault condition in which the device outputs are shorted to $\pm 15 \text{ V}$, and the power supplies are at low voltage and provide low-impedance paths to ground.

Figure 8. Power-Supply Protection to Meet
 Power-Off Fault Conditions of
 ANSI TIA/EIA-232-E

PACKAGING INFORMATION

Orderable Device	Status ⁽¹⁾	Package Type	Package Drawing	Pins	Package Qty	Eco Plan ⁽²⁾	Lead/Ball Finish	MSL Peak Temp ⁽³⁾
5962-86889012A	ACTIVE	LCCC	FK	20	1	TBD	POST-PLATE	N / A for Pkg Type
5962-8688901CA	ACTIVE	CDIP	J	14	1	TBD	A42 SNPB	N / A for Pkg Type
5962-8688901DA	ACTIVE	CFP	W	14	1	TBD	A42 SNPB	N / A for Pkg Type
MC1488N	ACTIVE	PDIP	N	14	25	Pb-Free (RoHS)	CU NIPDAU	N / A for Pkg Type
MC1488NE4	ACTIVE	PDIP	N	14	25	Pb-Free (RoHS)	CU NIPDAU	N / A for Pkg Type
SN55188J	ACTIVE	CDIP	J	14	1	TBD	A42 SNPB	N / A for Pkg Type
SN75188D	ACTIVE	SOIC	D	14	50	Green (RoHS & no Sb/Br)	CU NIPDAU	Level-1-260C-UNLIM
SN75188DE4	ACTIVE	SOIC	D	14	50	Green (RoHS & no Sb/Br)	CU NIPDAU	Level-1-260C-UNLIM
SN75188DG4	ACTIVE	SOIC	D	14	50	Green (RoHS & no Sb/Br)	CU NIPDAU	Level-1-260C-UNLIM
SN75188DR	ACTIVE	SOIC	D	14	2500	Green (RoHS & no Sb/Br)	CU NIPDAU	Level-1-260C-UNLIM
SN75188DRE4	ACTIVE	SOIC	D	14	2500	Green (RoHS & no Sb/Br)	CU NIPDAU	Level-1-260C-UNLIM
SN75188DRG4	ACTIVE	SOIC	D	14	2500	Green (RoHS & no Sb/Br)	CU NIPDAU	Level-1-260C-UNLIM
SN75188N	ACTIVE	PDIP	N	14	25	Pb-Free (RoHS)	CU NIPDAU	N / A for Pkg Type
SN75188NE4	ACTIVE	PDIP	N	14	25	Pb-Free (RoHS)	CU NIPDAU	N / A for Pkg Type
SN75188NSR	ACTIVE	SO	NS	14	2000	Green (RoHS & no Sb/Br)	CU NIPDAU	Level-1-260C-UNLIM
SN75188NSRE4	ACTIVE	SO	NS	14	2000	Green (RoHS & no Sb/Br)	CU NIPDAU	Level-1-260C-UNLIM
SN75188NSRG4	ACTIVE	SO	NS	14	2000	Green (RoHS & no Sb/Br)	CU NIPDAU	Level-1-260C-UNLIM
SNJ55188FK	ACTIVE	LCCC	FK	20	1	TBD	POST-PLATE	N / A for Pkg Type
SNJ55188J	ACTIVE	CDIP	J	14	1	TBD	A42 SNPB	N / A for Pkg Type
SNJ55188W	ACTIVE	CFP	W	14	1	TBD	A42 SNPB	N / A for Pkg Type

⁽¹⁾ The marketing status values are defined as follows:

ACTIVE: Product device recommended for new designs.

LIFEBUY: TI has announced that the device will be discontinued, and a lifetime-buy period is in effect.

NRND: Not recommended for new designs. Device is in production to support existing customers, but TI does not recommend using this part in a new design.

PREVIEW: Device has been announced but is not in production. Samples may or may not be available.

OBSOLETE: TI has discontinued the production of the device.

⁽²⁾ Eco Plan - The planned eco-friendly classification: Pb-Free (RoHS), Pb-Free (RoHS Exempt), or Green (RoHS & no Sb/Br) - please check <http://www.ti.com/productcontent> for the latest availability information and additional product content details.

TBD: The Pb-Free/Green conversion plan has not been defined.

Pb-Free (RoHS): TI's terms "Lead-Free" or "Pb-Free" mean semiconductor products that are compatible with the current RoHS requirements for all 6 substances, including the requirement that lead not exceed 0.1% by weight in homogeneous materials. Where designed to be soldered at high temperatures, TI Pb-Free products are suitable for use in specified lead-free processes.

Pb-Free (RoHS Exempt): This component has a RoHS exemption for either 1) lead-based flip-chip solder bumps used between the die and package, or 2) lead-based die adhesive used between the die and leadframe. The component is otherwise considered Pb-Free (RoHS compatible) as defined above.

Green (RoHS & no Sb/Br): TI defines "Green" to mean Pb-Free (RoHS compatible), and free of Bromine (Br) and Antimony (Sb) based flame retardants (Br or Sb do not exceed 0.1% by weight in homogeneous material)

⁽³⁾ MSL, Peak Temp. -- The Moisture Sensitivity Level rating according to the JEDEC industry standard classifications, and peak solder temperature.

Important Information and Disclaimer:The information provided on this page represents TI's knowledge and belief as of the date that it is provided. TI bases its knowledge and belief on information provided by third parties, and makes no representation or warranty as to the accuracy of such information. Efforts are underway to better integrate information from third parties. TI has taken and continues to take reasonable steps to provide representative and accurate information but may not have conducted destructive testing or chemical analysis on incoming materials and chemicals. TI and TI suppliers consider certain information to be proprietary, and thus CAS numbers and other limited information may not be available for release.

In no event shall TI's liability arising out of such information exceed the total purchase price of the TI part(s) at issue in this document sold by TI to Customer on an annual basis.



Carrier tape design is defined largely by the component length, width, and thickness.

A_o = Dimension designed to accommodate the component width.
B_o = Dimension designed to accommodate the component length.
K_o = Dimension designed to accommodate the component thickness.
W = Overall width of the carrier tape.
P = Pitch between successive cavity centers.

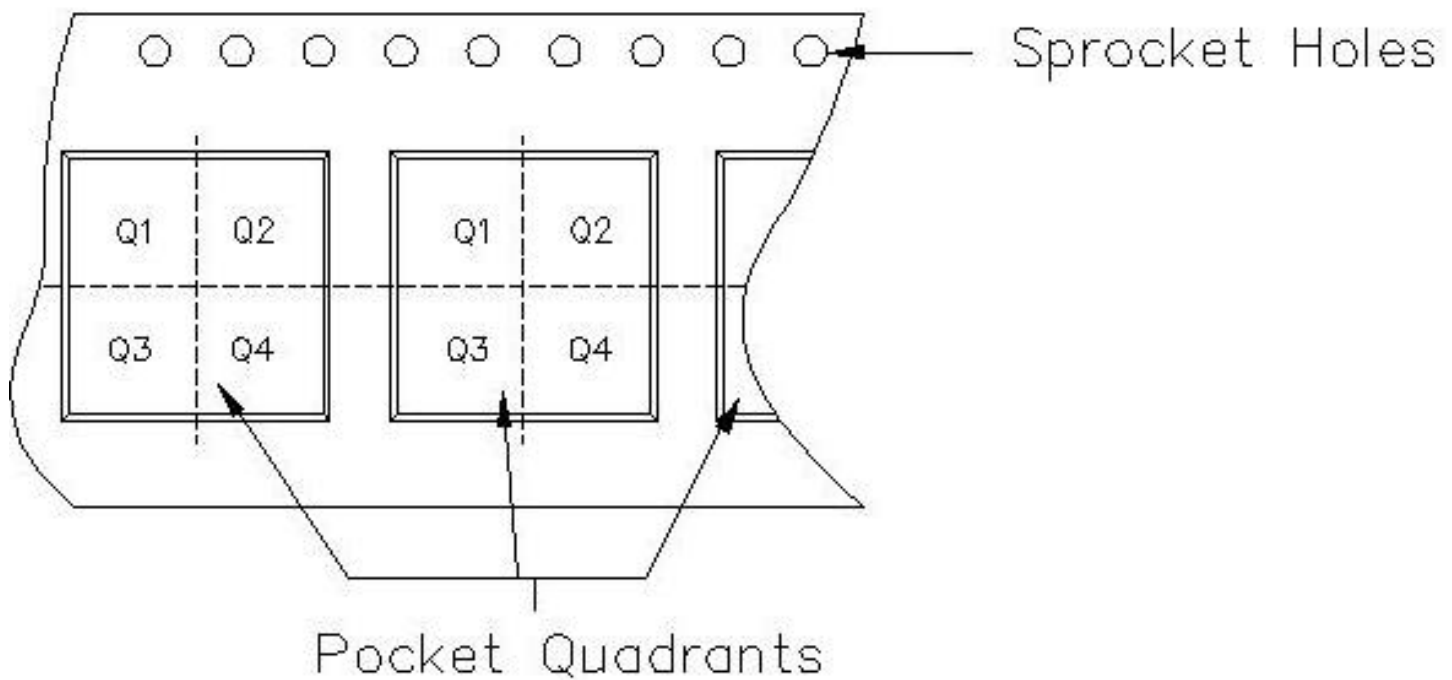

TAPE AND REEL INFORMATION

Device	Package	Pins	Site	Reel Diameter (mm)	Reel Width (mm)	A0 (mm)	B0 (mm)	K0 (mm)	P1 (mm)	W (mm)	Pin1 Quadrant
SN75188DR	D	14	MLA	330	16	6.5	9.0	2.1	8	16	Q1
SN75188NSR	NS	14	MLA	330	16	8.2	10.5	2.5	12	16	Q1

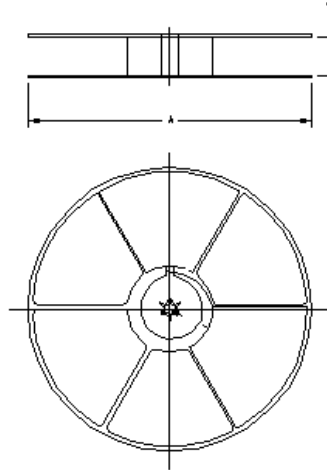

TAPE AND REEL BOX INFORMATION

Device	Package	Pins	Site	Length (mm)	Width (mm)	Height (mm)
SN75188DR	D	14	MLA	342.9	336.6	28.58
SN75188NSR	NS	14	MLA	342.9	336.6	28.58

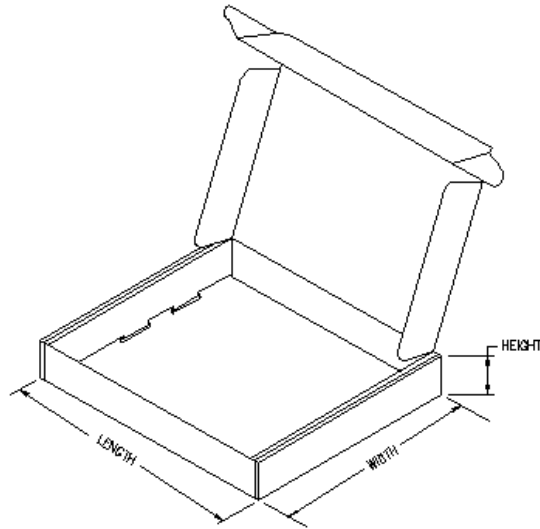

J (R-GDIP-T**)

14 LEADS SHOWN

CERAMIC DUAL IN-LINE PACKAGE



DIM \ PINS **	14	16	18	20
A	0.300 (7,62) BSC	0.300 (7,62) BSC	0.300 (7,62) BSC	0.300 (7,62) BSC
B MAX	0.785 (19,94)	.840 (21,34)	0.960 (24,38)	1.060 (26,92)
B MIN	—	—	—	—
C MAX	0.300 (7,62)	0.300 (7,62)	0.310 (7,87)	0.300 (7,62)
C MIN	0.245 (6,22)	0.245 (6,22)	0.220 (5,59)	0.245 (6,22)



4040083/F 03/03

- NOTES:
- All linear dimensions are in inches (millimeters).
 - This drawing is subject to change without notice.
 - This package is hermetically sealed with a ceramic lid using glass frit.
 - Index point is provided on cap for terminal identification only on press ceramic glass frit seal only.
 - Falls within MIL STD 1835 GDIP1-T14, GDIP1-T16, GDIP1-T18 and GDIP1-T20.

W (R-GDFP-F14)

CERAMIC DUAL FLATPACK



4040180-2/D 07/03

- NOTES:
- A. All linear dimensions are in inches (millimeters).
 - B. This drawing is subject to change without notice.
 - C. This package can be hermetically sealed with a ceramic lid using glass frit.
 - D. Index point is provided on cap for terminal identification only.
 - E. Falls within MIL STD 1835 GDFP1-F14 and JEDEC MO-092AB

FK (S-CQCC-N**)

LEADLESS CERAMIC CHIP CARRIER

28 TERMINAL SHOWN



- NOTES:
- A. All linear dimensions are in inches (millimeters).
 - B. This drawing is subject to change without notice.
 - C. This package can be hermetically sealed with a metal lid.
 - D. The terminals are gold plated.
 - E. Falls within JEDEC MS-004

N (R-PDIP-T**)

PLASTIC DUAL-IN-LINE PACKAGE

16 PINS SHOWN



- NOTES:
- A. All linear dimensions are in inches (millimeters).
 - B. This drawing is subject to change without notice.
 - (C) Falls within JEDEC MS-001, except 18 and 20 pin minimum body length (Dim A).
 - (D) The 20 pin end lead shoulder width is a vendor option, either half or full width.

D (R-PDSO-G14)

PLASTIC SMALL-OUTLINE PACKAGE



4040047-3/H 11/2006

- NOTES:
- A. All linear dimensions are in inches (millimeters).
 - B. This drawing is subject to change without notice.
 - $\triangle C$ Body length does not include mold flash, protrusions, or gate burrs. Mold flash, protrusions, or gate burrs shall not exceed .006 (0,15) per end.
 - $\triangle D$ Body width does not include interlead flash. Interlead flash shall not exceed .017 (0,43) per side.
 - E. Reference JEDEC MS-012 variation AB.

MECHANICAL DATA

NS (R-PDSO-G**)

PLASTIC SMALL-OUTLINE PACKAGE

14-PINS SHOWN



- NOTES:
- A. All linear dimensions are in millimeters.
 - B. This drawing is subject to change without notice.
 - C. Body dimensions do not include mold flash or protrusion, not to exceed 0,15.

IMPORTANT NOTICE

Texas Instruments Incorporated and its subsidiaries (TI) reserve the right to make corrections, modifications, enhancements, improvements, and other changes to its products and services at any time and to discontinue any product or service without notice. Customers should obtain the latest relevant information before placing orders and should verify that such information is current and complete. All products are sold subject to TI's terms and conditions of sale supplied at the time of order acknowledgment.

TI warrants performance of its hardware products to the specifications applicable at the time of sale in accordance with TI's standard warranty. Testing and other quality control techniques are used to the extent TI deems necessary to support this warranty. Except where mandated by government requirements, testing of all parameters of each product is not necessarily performed.

TI assumes no liability for applications assistance or customer product design. Customers are responsible for their products and applications using TI components. To minimize the risks associated with customer products and applications, customers should provide adequate design and operating safeguards.

TI does not warrant or represent that any license, either express or implied, is granted under any TI patent right, copyright, mask work right, or other TI intellectual property right relating to any combination, machine, or process in which TI products or services are used. Information published by TI regarding third-party products or services does not constitute a license from TI to use such products or services or a warranty or endorsement thereof. Use of such information may require a license from a third party under the patents or other intellectual property of the third party, or a license from TI under the patents or other intellectual property of TI.

Reproduction of TI information in TI data books or data sheets is permissible only if reproduction is without alteration and is accompanied by all associated warranties, conditions, limitations, and notices. Reproduction of this information with alteration is an unfair and deceptive business practice. TI is not responsible or liable for such altered documentation. Information of third parties may be subject to additional restrictions.

Resale of TI products or services with statements different from or beyond the parameters stated by TI for that product or service voids all express and any implied warranties for the associated TI product or service and is an unfair and deceptive business practice. TI is not responsible or liable for any such statements.

TI products are not authorized for use in safety-critical applications (such as life support) where a failure of the TI product would reasonably be expected to cause severe personal injury or death, unless officers of the parties have executed an agreement specifically governing such use. Buyers represent that they have all necessary expertise in the safety and regulatory ramifications of their applications, and acknowledge and agree that they are solely responsible for all legal, regulatory and safety-related requirements concerning their products and any use of TI products in such safety-critical applications, notwithstanding any applications-related information or support that may be provided by TI. Further, Buyers must fully indemnify TI and its representatives against any damages arising out of the use of TI products in such safety-critical applications.

TI products are neither designed nor intended for use in military/aerospace applications or environments unless the TI products are specifically designated by TI as military-grade or "enhanced plastic." Only products designated by TI as military-grade meet military specifications. Buyers acknowledge and agree that any such use of TI products which TI has not designated as military-grade is solely at the Buyer's risk, and that they are solely responsible for compliance with all legal and regulatory requirements in connection with such use.

TI products are neither designed nor intended for use in automotive applications or environments unless the specific TI products are designated by TI as compliant with ISO/TS 16949 requirements. Buyers acknowledge and agree that, if they use any non-designated products in automotive applications, TI will not be responsible for any failure to meet such requirements.

Following are URLs where you can obtain information on other Texas Instruments products and application solutions:

Products		Applications	
Amplifiers	amplifier.ti.com	Audio	www.ti.com/audio
Data Converters	dataconverter.ti.com	Automotive	www.ti.com/automotive
DSP	dsp.ti.com	Broadband	www.ti.com/broadband
Interface	interface.ti.com	Digital Control	www.ti.com/digitalcontrol
Logic	logic.ti.com	Military	www.ti.com/military
Power Mgmt	power.ti.com	Optical Networking	www.ti.com/opticalnetwork
Microcontrollers	microcontroller.ti.com	Security	www.ti.com/security
RFID	www.ti-rfid.com	Telephony	www.ti.com/telephony
Low Power Wireless	www.ti.com/lpw	Video & Imaging	www.ti.com/video
		Wireless	www.ti.com/wireless

Mailing Address: Texas Instruments, Post Office Box 655303, Dallas, Texas 75265
Copyright © 2007, Texas Instruments Incorporated