



24C08B/16B

8K/16K 5.0V I²C™ Serial EEPROMs

FEATURES

- Single supply with operation from 4.5-5.5V
- Low power CMOS technology
 - 1 mA active current typical
 - 10 μ A standby current typical at 5.5V
- Organized as 4 or 8 blocks of 256 bytes (4 x 256 x 8) or (8 x 256 x 8)
- 2-wire serial interface bus, I²C™ compatible
- Schmitt trigger, filtered inputs for noise suppression
- Output slope control to eliminate ground bounce
- 100 kHz compatibility
- Self-timed write cycle (including auto-erase)
- Page-write buffer for up to 16 bytes
- 2 ms typical write cycle time for page-write
- Hardware write protect for entire memory
- Can be operated as a serial ROM
- ESD protection > 4,000V
- 1,000,000 ERASE/WRITE cycles guaranteed
- Data retention > 200 years
- 8-pin DIP, 8-lead or 14-lead SOIC packages
- Available for extended temperature range
 - Automotive (E): -40°C to +125°C

DESCRIPTION

The Microchip Technology Inc. 24C08B/16B is an 8K or 16K bit Electrically Erasable PROM intended for use in extended/automotive temperature ranges. The device is organized as four or eight blocks of 256 x 8-bit memory with a 2-wire serial interface. The 24C08B/16B also has a page-write capability for up to 16 bytes of data. The 24C08B/16B is available in the standard 8-pin DIP and both 8-lead and 14-lead surface mount SOIC packages.

PACKAGE TYPES

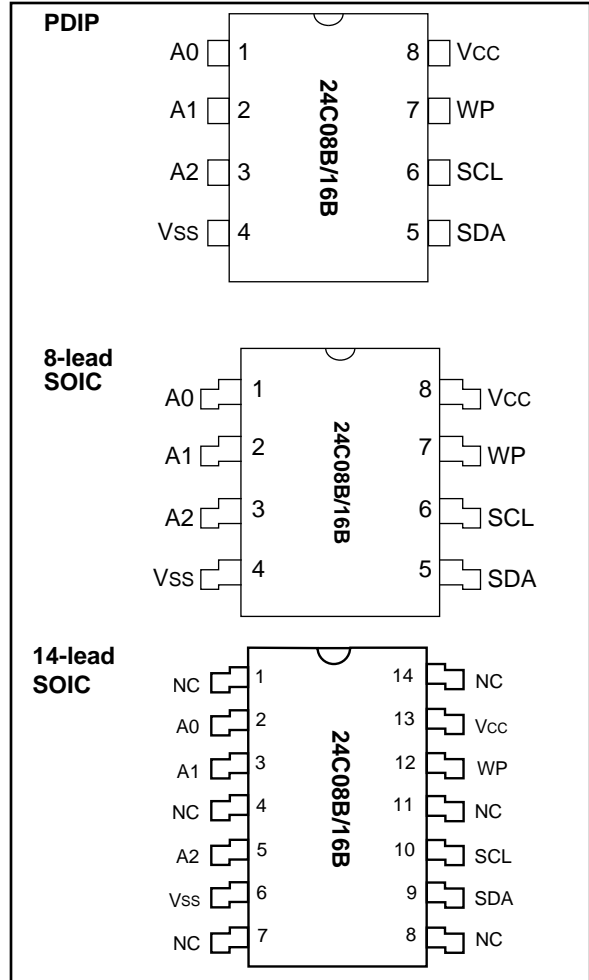

BLOCK DIAGRAM

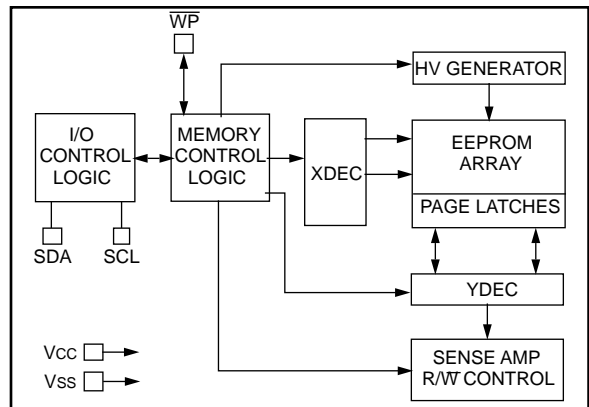

I²C is a trademark of Philips Corporation.

24C08B/16B

1.0 ELECTRICAL CHARACTERISTICS

1.1 Maximum Ratings*

V_{CC}.....7.0V
 All inputs and outputs w.r.t. V_{SS} -0.6V to V_{CC} +1.0V
 Storage temperature -65°C to +150°C
 Ambient temp. with power applied -65°C to +125°C
 Soldering temperature of leads (10 seconds) +300°C
 ESD protection on all pins ≥ 4 kV

***Notice:** Stresses above those listed under "Maximum ratings" may cause permanent damage to the device. This is a stress rating only and functional operation of the device at those or any other conditions above those indicated in the operational listings of this specification is not implied. Exposure to maximum rating conditions for extended periods may affect device reliability.

TABLE 1-1: PIN FUNCTION TABLE

Name	Function
V _{SS}	Ground
SDA	Serial Address/Data I/O
SCL	Serial Clock
WP	Write Protect Input
V _{CC}	+4.5V to 5.5V Power Supply
A0, A1, A2	No Internal Connection

TABLE 1-2: DC CHARACTERISTICS

V _{CC} = +4.5V to +5.5V Automotive (E): T _{amb} = -40°C to +125°C					
Parameter	Symbol	Min	Max	Units	Conditions
WP, SCL and SDA pins:					
High level input voltage	V _{IH}	.7 V _{CC}	—	V	(Note)
Low Level input voltage	V _{IL}	—	.3 V _{CC}	V	
Hysteresis of Schmitt trigger inputs	V _{HYS}	.05 V _{CC}	—	V	
Low level output voltage	V _{OL}	—	.40	V	
Input leakage current	I _{LI}	-10	10	μA	V _{IN} = .1V to V _{CC}
Output leakage current	I _{LO}	-10	10	μA	V _{OUT} = .1V to V _{CC}
Pin capacitance (all inputs/outputs)	C _{IN} , C _{OUT}	—	10	pF	V _{CC} = 5.0V (Note 1) T _{amb} = 25°C, F _{CLK} =1 MHz
Operating current	I _{CC} write	—	3	mA	V _{CC} = 5.5V, SCL = 400 kHz
	I _{CC} read	—	1	mA	
Standby current	I _{CCS}	—	100	μA	V _{CC} = 5.5V, SDA = SCL = V _{CC}

Note: This parameter is periodically sampled and not 100% tested.

FIGURE 1-1: BUS TIMING START/STOP

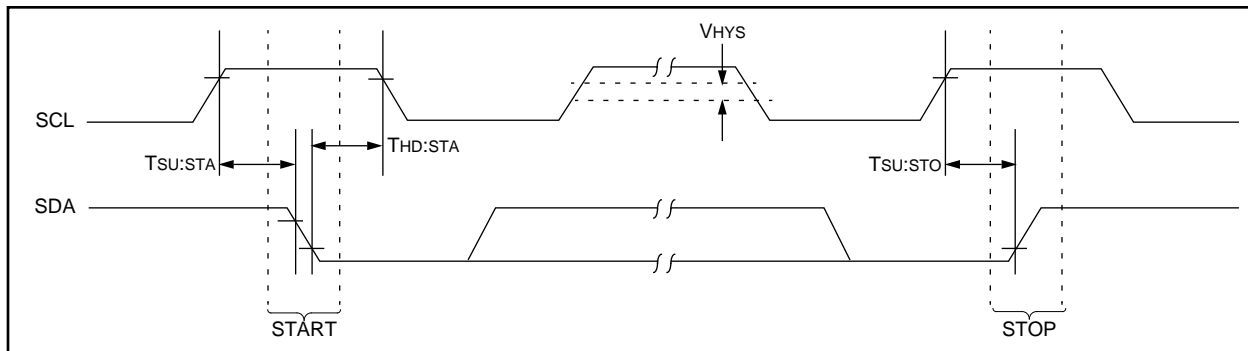
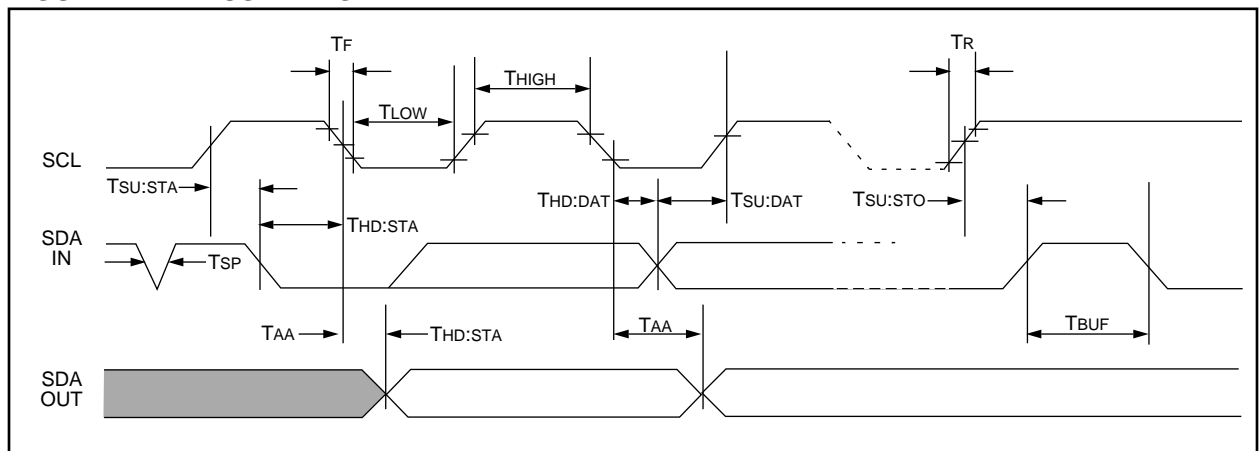

TABLE 1-3: AC CHARACTERISTICS

Parameter	Symbol	Min	Max	Units	Remarks	
Clock frequency	FCLK	—	100	kHz		
Clock high time	THIGH	4000	—	ns		
Clock low time	TLOW	4700	—	ns		
SDA and SCL rise time	TR	—	1000	ns	(Note1)	
SDA and SCL fall time	TF	—	300	ns	(Note 1)	
START condition hold time	THD:STA	4000	—	ns	After this period the first clock pulse is generated	
START condition setup time	TSU:STA	4700	—	ns	Only relevant for repeated START condition	
Data input hold time	THD:DAT	0	—	ns		
Data input setup time	TSU:DAT	250	—	ns		
STOP condition setup time	TSU:STO	4000	—	ns		
Output valid from clock	TAA	—	3500	ns	(Note 2)	
Bus free time	TBUF	4700	—	ns	Time the bus must be free before a new transmission can start	
Output fall time from VIH min to VIL max	TOF	—	250	ns	(Note 1), CB ≤ 100 pF	
Input filter spike suppression (SDA and SCL pins)	TSP	—	50	ns	(Note 3)	
Write cycle time	TWR	—	10	ms	Byte or Page mode	
Endurance	24C08B 24C16B	— —	1M 10M	— —	cycles cycles	25°C, VCC = 5.0V, Block Mode (Note 4)

- Note 1: Not 100% tested. CB = total capacitance of one bus line in pF.
 Note 2: As a transmitter, the device must provide an internal minimum delay time to bridge the undefined region (minimum 300 ns) of the falling edge of SCL to avoid unintended generation of START or STOP conditions.
 Note 3: The combined TSP and VHYS specifications are due to new Schmitt trigger inputs which provide improved noise and spike suppression. This eliminates the need for a TI specification.
 Note 4: This parameter is not tested but guaranteed by characterization. For endurance estimates in a specific application, please consult the Total Endurance Model which can be obtained on our BBS or website.

FIGURE 1-2: BUS TIMING DATA



24C08B/16B

2.0 FUNCTIONAL DESCRIPTION

The 24C08B/16B supports a Bi-directional 2-wire bus and data transmission protocol. A device that sends data onto the bus is defined as transmitter, and a device receiving data as receiver. The bus has to be controlled by a master device which generates the serial clock (SCL), controls the bus access, and generates the START and STOP conditions, while the 24C08B/16B works as slave. Both, master and slave can operate as transmitter or receiver but the master device determines which mode is activated.

3.0 BUS CHARACTERISTICS

The following **bus protocol** has been defined:

- Data transfer may be initiated only when the bus is not busy.
- During data transfer, the data line must remain stable whenever the clock line is HIGH. Changes in the data line while the clock line is HIGH will be interpreted as a START or STOP condition.

Accordingly, the following bus conditions have been defined (Figure 3-1).

3.1 Bus not Busy (A)

Both data and clock lines remain HIGH.

3.2 Start Data Transfer (B)

A HIGH to LOW transition of the SDA line while the clock (SCL) is HIGH determines a START condition. All commands must be preceded by a START condition.

3.3 Stop Data Transfer (C)

A LOW to HIGH transition of the SDA line while the clock (SCL) is HIGH determines a STOP condition. All operations must be ended with a STOP condition.

3.4 Data Valid (D)

The state of the data line represents valid data when, after a START condition, the data line is stable for the duration of the HIGH period of the clock signal.

The data on the line must be changed during the LOW period of the clock signal. There is one clock pulse per bit of data.

Each data transfer is initiated with a START condition and terminated with a STOP condition. The number of the data bytes transferred between the START and STOP conditions is determined by the master device and is theoretically unlimited, although only the last 16 will be stored when doing a write operation. When an overwrite does occur it will replace data in a first in first out fashion.

3.5 Acknowledge

Each receiving device, when addressed, is obliged to generate an acknowledge after the reception of each byte. The master device must generate an extra clock pulse which is associated with this acknowledge bit.

Note: The 24C08B/16B does not generate any acknowledge bits if an internal programming cycle is in progress.

The device that acknowledges, has to pull down the SDA line during the acknowledge clock pulse in such a way that the SDA line is stable LOW during the HIGH period of the acknowledge related clock pulse. Of course, setup and hold times must be taken into account. During reads, a master must signal an end of data to the slave by NOT generating an acknowledge bit on the last byte that has been clocked out of the slave. In this case, the slave (24C08B/16B) will leave the data line HIGH to enable the master to generate the STOP condition.

FIGURE 3-1: DATA TRANSFER SEQUENCE ON THE SERIAL BUS

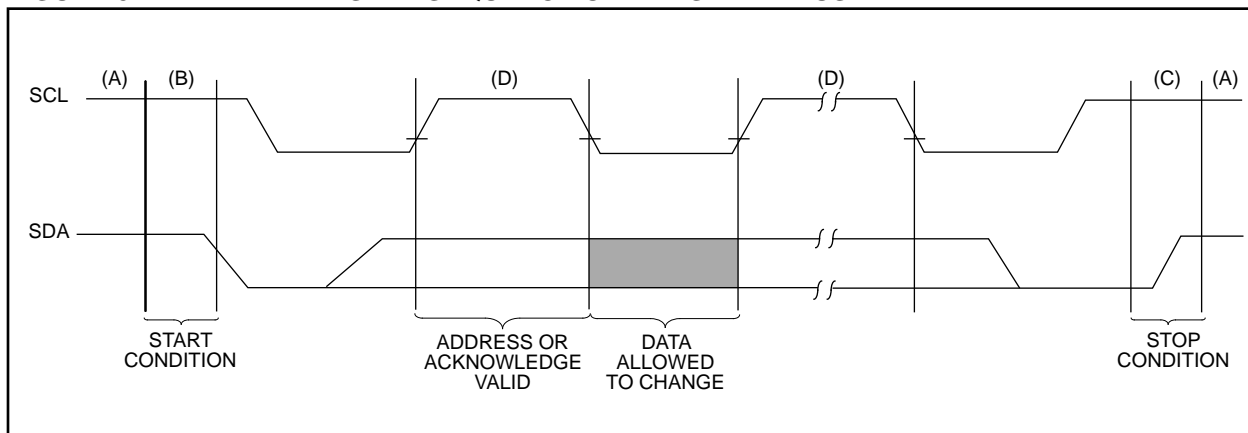

3.6 Device Addressing

A control byte is the first byte received following the start condition from the master device. The control byte consists of a 4-bit control code, for the 24C08B/16B this is set as 1010 binary for read and write operations. The next three bits of the control byte are the block select bits (B2, B1, B0). They are used by the master device to select which of the eight 256 word blocks of memory are to be accessed. These bits are in effect the three most significant bits of the word address.

The last bit of the control byte defines the operation to be performed. When set to one a read operation is selected, when set to zero a write operation is selected. Following the start condition, the 24C08B/16B monitors the SDA bus checking the device type identifier being transmitted, upon a 1010 code the slave device outputs an acknowledge signal on the SDA line. Depending on the state of the R/W bit, the 24C08B/16B will select a read or write operation.

Operation	Control Code	Block Select	R/W
Read	1010	Block Address	1
Write	1010	Block Address	0

FIGURE 3-2: CONTROL BYTE ALLOCATION

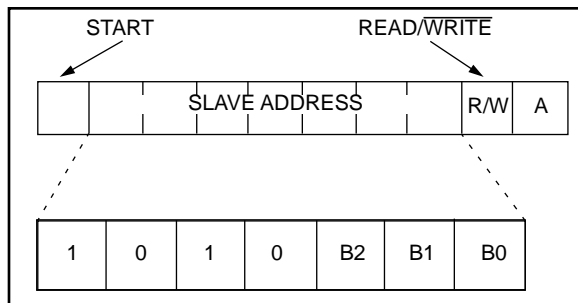

4.0 WRITE OPERATION

4.1 Byte Write

Following the start condition from the master, the device code (4 bits), the block address (3 bits), and the R/W bit which is a logic low is placed onto the bus by the master transmitter. This indicates to the addressed slave receiver that a byte with a word address will follow after it has generated an acknowledge bit during the ninth clock cycle. Therefore the next byte transmitted by the master is the word address and will be written into the address pointer of the 24C08B/16B. After receiving another acknowledge signal from the 24C08B/16B the master device will transmit the data word to be written into the addressed memory location. The 24C08B/16B acknowledges again and the master generates a stop condition. This initiates the internal write cycle, and during this time the 24C08B/16B will not generate acknowledge signals (Figure 4-1).

4.2 Page Write

The write control byte, word address and the first data byte are transmitted to the 24C08B/16B in the same way as in a byte write. But instead of generating a stop condition the master transmits up to 16 data bytes to the 24C08B/16B which are temporarily stored in the on-chip page buffer and will be written into the memory after the master has transmitted a stop condition. After the receipt of each word, the four lower order address pointer bits are internally incremented by one. The higher order seven bits of the word address remains constant. If the master should transmit more than 16 words prior to generating the stop condition, the address counter will roll over and the previously received data will be overwritten. As with the byte write operation, once the stop condition is received an internal write cycle will begin (Figure 4-2).

FIGURE 4-1: BYTE WRITE

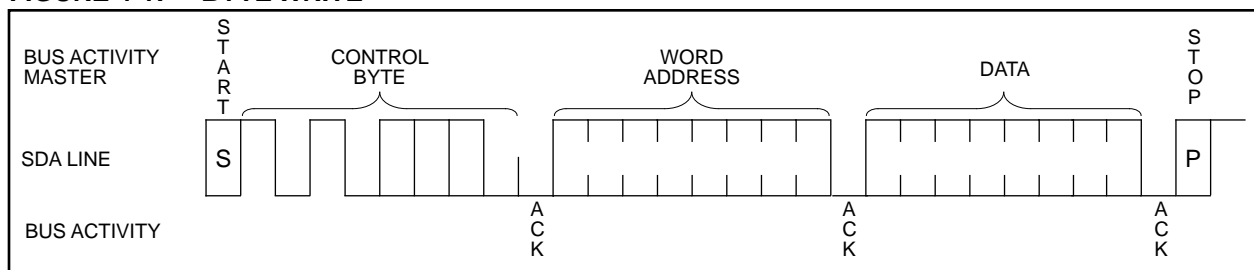
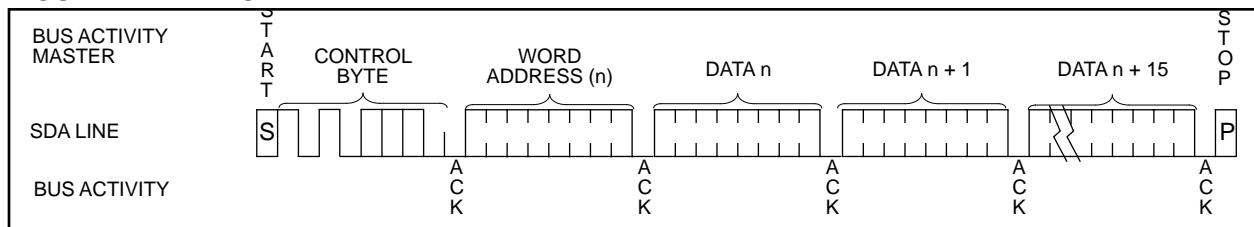

FIGURE 4-2: PAGE WRITE



5.0 ACKNOWLEDGE POLLING

Since the device will not acknowledge during a write cycle, this can be used to determine when the cycle is complete (this feature can be used to maximize bus throughput). Once the stop condition for a write command has been issued from the master, the device initiates the internally timed write cycle. ACK polling can be initiated immediately. This involves the master sending a start condition followed by the control byte for a write command ($R/\bar{W} = 0$). If the device is still busy with the write cycle, then no ACK will be returned. If the cycle is complete, then the device will return the ACK and the master can then proceed with the next read or write command. See Figure 5-1 for flow diagram.

FIGURE 5-1: ACKNOWLEDGE POLLING FLOW

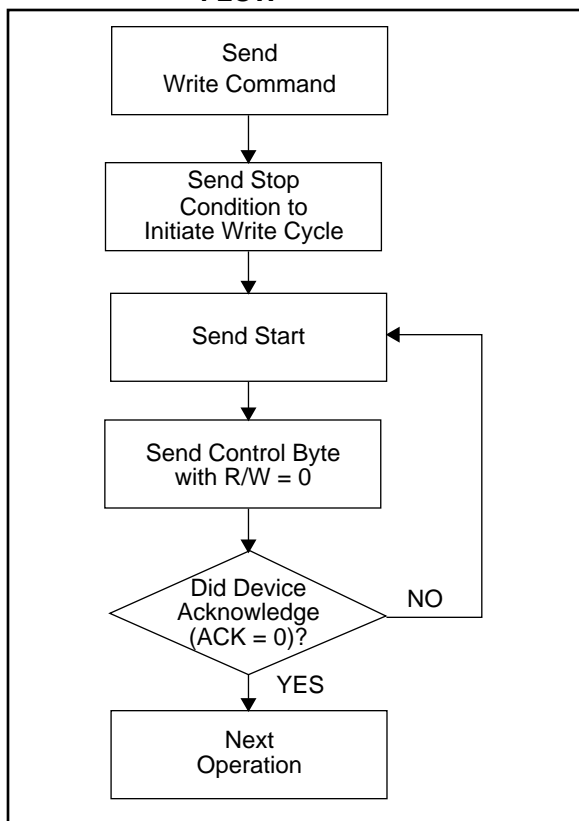

6.0 WRITE PROTECTION

The 24C08B/16B can be used as a serial ROM when the WP pin is connected to VCC. Programming will be inhibited and the entire memory will be write-protected.

7.0 READ OPERATION

Read operations are initiated in the same way as write operations with the exception that the R/\bar{W} bit of the slave address is set to one. There are three basic types of read operations: current address read, random read, and sequential read.

7.1 Current Address Read

The 24C08B/16B contains an address counter that maintains the address of the last word accessed, internally incremented by one. Therefore, if the previous access (either a read or write operation) was to address n , the next current address read operation would access data from address $n + 1$. Upon receipt of the slave address with R/\bar{W} bit set to one, the 24C08B/16B issues an acknowledge and transmits the 8-bit data word. The master will not acknowledge the transfer but does generate a stop condition and the 24C08B/16B discontinues transmission (Figure 7-1).

7.2 Random Read

Random read operations allow the master to access any memory location in a random manner. To perform this type of read operation, first the word address must be set. This is done by sending the word address to the 24C08B/16B as part of a write operation. After the word address is sent, the master generates a start condition following the acknowledge. This terminates the write operation, but not before the internal address pointer is set. Then the master issues the control byte again but with the R/\bar{W} bit set to a one. The 24C08B/16B will then issue an acknowledge and transmits the 8-bit data word. The master will not acknowledge the transfer but does generate a stop condition and the 24C08B/16B discontinues transmission (Figure 7-2).

7.3 Sequential Read

Sequential reads are initiated in the same way as a random read except that after the 24C08B/16B transmits the first data byte, the master issues an acknowledge as opposed to a stop condition in a random read. This directs the 24C08B/16B to transmit the next sequentially addressed 8 bit word (Figure 7-3).

To provide sequential reads the 24C08B/16B contains an internal address pointer which is incremented by one at the completion of each operation. This address pointer allows the entire memory contents to be serially read during one operation.

7.4 Noise Protection

The 24C08B/16B employs a VCC threshold detector circuit which disables the internal erase/write logic if the VCC is below 1.5 volts at nominal conditions.

The SCL and SDA inputs have Schmitt trigger and filter circuits which suppress noise spikes to assure proper device operation even on a noisy bus.

FIGURE 7-1: CURRENT ADDRESS READ

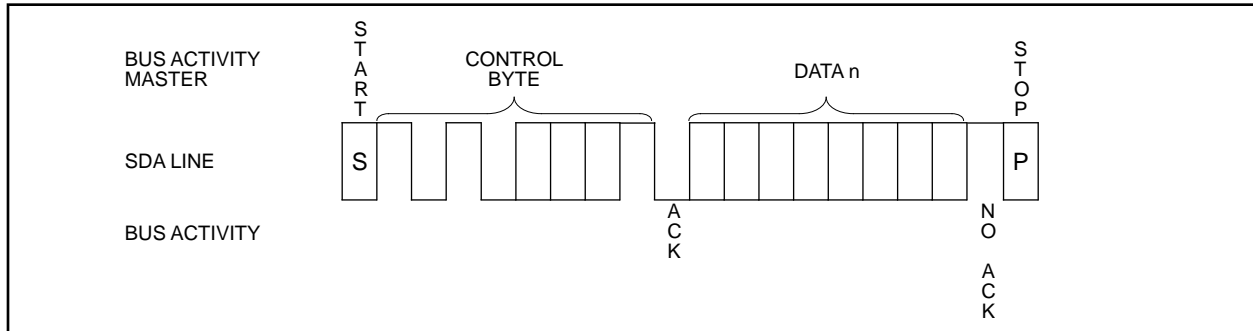

FIGURE 7-2: RANDOM READ

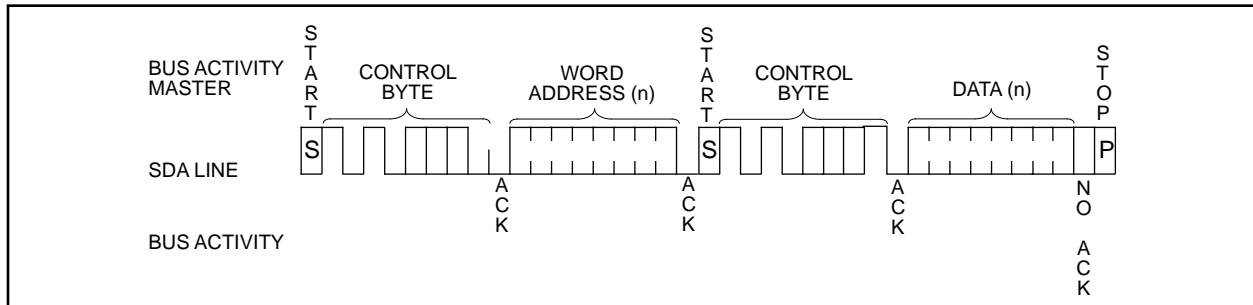
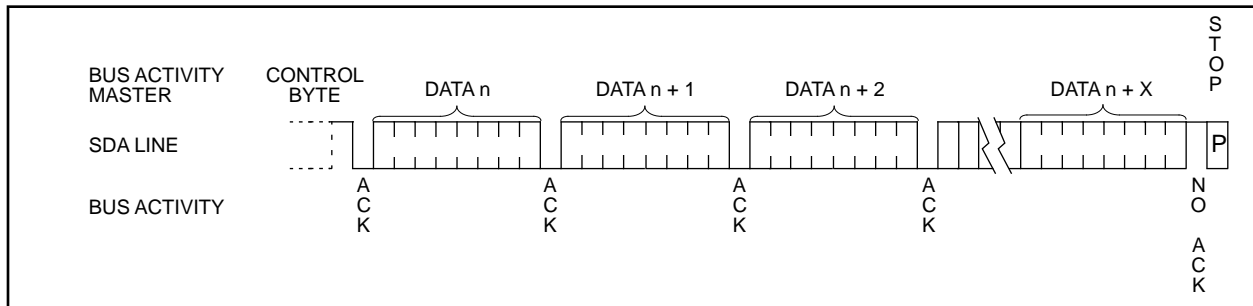

FIGURE 7-3: SEQUENTIAL READ



8.0 PIN DESCRIPTIONS

8.1 SDA Serial Address/Data Input/Output

This is a Bi-directional pin used to transfer addresses and data into and data out of the device. It is an open drain terminal, therefore the SDA bus requires a pull-up resistor to Vcc (typical 10Ω).

For normal data transfer SDA is allowed to change only during SCL low. Changes during SCL high are reserved for indicating the START and STOP conditions.

8.2 SCL Serial Clock

This input is used to synchronize the data transfer from and to the device.

8.3 WP

This pin must be connected to either Vss or Vcc.

If tied to Vss, normal memory operation is enabled (read/write the entire memory 000-7FF).

If tied to Vcc, WRITE operations are inhibited. The entire memory will be write-protected. Read operations are not affected.

This feature allows the user to use the 24C08B/16B as a serial ROM when WP is enabled (tied to Vcc).

8.4 A0, A1, A2

These pins are not used by the 24C08B/16B. They may be left floating or tied to either Vss or Vcc.

24C08B/16B

NOTES:

NOTES:

24C08B/16B

NOTES:

24C08B/16B

24C08B/16B Product Identification System

To order or to obtain information, e.g., on pricing or delivery, please use the listed part numbers, and refer to the factory or the listed sales offices.

24C08B/16B	-	E	/ P	
				Package:
				P = Plastic DIP (300 mil Body), 8-lead
				SL = Plastic SOIC (150 mil Body), 14-lead
				SN = Plastic SOIC (150 mil Body), 8-lead
				Temperature Range:
				E = -40°C to +125°C
				Device:
				24C08B 8K I ² C Serial EEPROM
				24C08BT 8K I ² C Serial EEPROM (Tape and Reel)
				24C16B 16K I ² C Serial EEPROM
				24C16BT 16K I ² C Serial EEPROM (Tape and Reel)

WORLDWIDE SALES & SERVICE

AMERICAS

Corporate Office

Microchip Technology Inc.
2355 West Chandler Blvd.
Chandler, AZ 85224-6199
Tel: 602 786-7200 Fax: 602 786-7277
Technical Support: 602 786-7627
Web: <http://www.microchip.com>

Atlanta

Microchip Technology Inc.
500 Sugar Mill Road, Suite 200B
Atlanta, GA 30350
Tel: 770 640-0034 Fax: 770 640-0307

Boston

Microchip Technology Inc.
5 Mount Royal Avenue
Marlborough, MA 01752
Tel: 508 480-9990 Fax: 508 480-8575

Chicago

Microchip Technology Inc.
333 Pierce Road, Suite 180
Itasca, IL 60143
Tel: 708 285-0071 Fax: 708 285-0075

Dallas

Microchip Technology Inc.
14651 Dallas Parkway, Suite 816
Dallas, TX 75240-8809
Tel: 972 991-7177 Fax: 972 991-8588

Dayton

Microchip Technology Inc.
Suite 150
Two Prestige Place
Miamisburg, OH 45342
Tel: 513 291-1654 Fax: 513 291-9175

Los Angeles

Microchip Technology Inc.
18201 Von Karman, Suite 1090
Irvine, CA 92612
Tel: 714 263-1888 Fax: 714 263-1338

New York

Microchip Technmgy Inc.
150 Motor Parkway, Suite 416
Hauppauge, NY 11788
Tel: 516 273-5305 Fax: 516 273-5335

San Jose

Microchip Technology Inc.
2107 North First Street, Suite 590
San Jose, CA 95131
Tel: 408 436-7950 Fax: 408 436-7955

Toronto

Microchip Technology Inc.
5925 Airport Road, Suite 200
Mississauga, Ontario L4V 1W1, Canada
Tel: 905 405-6279 Fax: 905 405-6253

ASIA/PACIFIC

China

Microchip Technology
Unit 406 of Shanghai Golden Bridge Bldg.
2077 Yan'an Road West, Hongjiao District
Shanghai, Peoples Republic of China
Tel: 86 21 6275 5700
Fax: 011 86 21 6275 5060

Hong Kong

Microchip Technology
RM 3801B, Tower Two
Metroplaza
223 Hing Fong Road
Kwai Fong, N.T. Hong Kong
Tel: 852 2 401 1200 Fax: 852 2 401 3431

India

Microchip Technology
No. 6, Legacy, Convent Road
Bangalore 560 025 India
Tel: 91 80 526 3148 Fax: 91 80 559 9840

Korea

Microchip Technology
168-1, Youngbo Bldg. 3 Floor
Samsung-Dong, Kangnam-Ku,
Seoul, Korea
Tel: 82 2 554 7200 Fax: 82 2 558 5934

Singapore

Microchip Technology
200 Middle Road
#10-03 Prime Centre
Singapore 188980
Tel: 65 334 8870 Fax: 65 334 8850

Taiwan, R.O.C

Microchip Technology
10F-1C 207
Tung Hua North Road
Taipei, Taiwan, ROC
Tel: 886 2 717 7175 Fax: 886 2 545 0139

EUROPE

United Kingdom

Arizona Microchip Technology Ltd.
Unit 6, The Courtyard
Meadow Bank, Furlong Road
Bourne End, Buckinghamshire SL8 5AJ
Tel: 44 1628 850303 Fax: 44 1628 850178

France

Arizona Microchip Technology SARL
Zone Industrielle de la Bonde
2 Rue du Buisson aux Fraises
91300 Massy - France
Tel: 33 1 69 53 63 20 Fax: 33 1 69 30 90 79

Germany

Arizona Microchip Technology GmbH
Gustav-Heinemann-Ring 125
D-81739 Muenchen, Germany
Tel: 49 89 627 144 0 Fax: 49 89 627 144 44

Italy

Arizona Microchip Technology SRL
Centro Direzionale Colleone Pas Taurus 1
Viale Colleoni 1
20041 Agrate Brianza
Milan Italy
Tel: 39 39 6899939 Fax: 39 39 689 9883

JAPAN

Microchip Technology Intl. Inc.
Benex S-1 6F
3-18-20, Shin Yokohama
Kohoku-Ku, Yokohama
Kanagawa 222 Japan
Tel: 81 45 471 6166 Fax: 81 45 471 6122

9/3/96



MICROCHIP

All rights reserved. © 1996, Microchip Technology Incorporated, USA. 9/96



Printed on recycled paper.

Information contained in this publication regarding device applications and the like is intended through suggestion only and may be superseded by updates. No representation or warranty is given and no liability is assumed by Microchip Technology Incorporated with respect to the accuracy or use of such information, or infringement of patents or other intellectual property rights arising from such use or otherwise. Use of Microchip's products as critical components in life support systems is not authorized except with express written approval by Microchip. No licenses are conveyed, implicitly or otherwise, under any intellectual property rights. The Microchip logo and name are registered trademarks of Microchip Technology Inc. All rights reserved. All other trademarks mentioned herein are the property of their respective companies.

This datasheet has been downloaded from:

www.DatasheetCatalog.com

Datasheets for electronic components.



LittleDiode supplies new, hard to find or obsolete electronic components and semiconductors all over the world.

With over two million different components listed you are sure to find the part you need.

Feel free to visit us today at our online store:

LittleDiode.com

Looking forward to providing you with the best possible service.