

HIGH SIDE MONOLITHIC SWITCH IN MULTIPOWER-BCD TECHNOLOGY

by C.Cini, C. Diazzi, D. Rossi, S. Storti

Recent advances in integrated circuit technology have allowed the realization of a new mixed process integrating isolated DMOS power transistors in combination with bipolar and CMOS signal structures on the same chip. Called Multipower-BCD, this technology has been used to realize a monolithic self-protected high-side switch mainly intended for automotive applications. Driven by TTL, CMOS input logic it can supply resistive or inductive loads up to 6A DC allowing a current peak of 25A with an $R_{DS(on)} = 0.1\Omega$. Fault conditions are signaled on a diagnostic output pin.

ELECTRONIC POWER SWITCHES IN THE CAR

The increase of the number of the electrical components in the car (today more than 50) and the increase in assembly costs shall soon make economical multiplexed power supply and control systems. These systems consist of a single line for power supply and a multiplexed signal network for control; in this way it is not necessary to have a wire for every load, but only a common power line and a common signal line for all the loads (fig. 1).

Figure 1 : Example of a Multiplexed System.

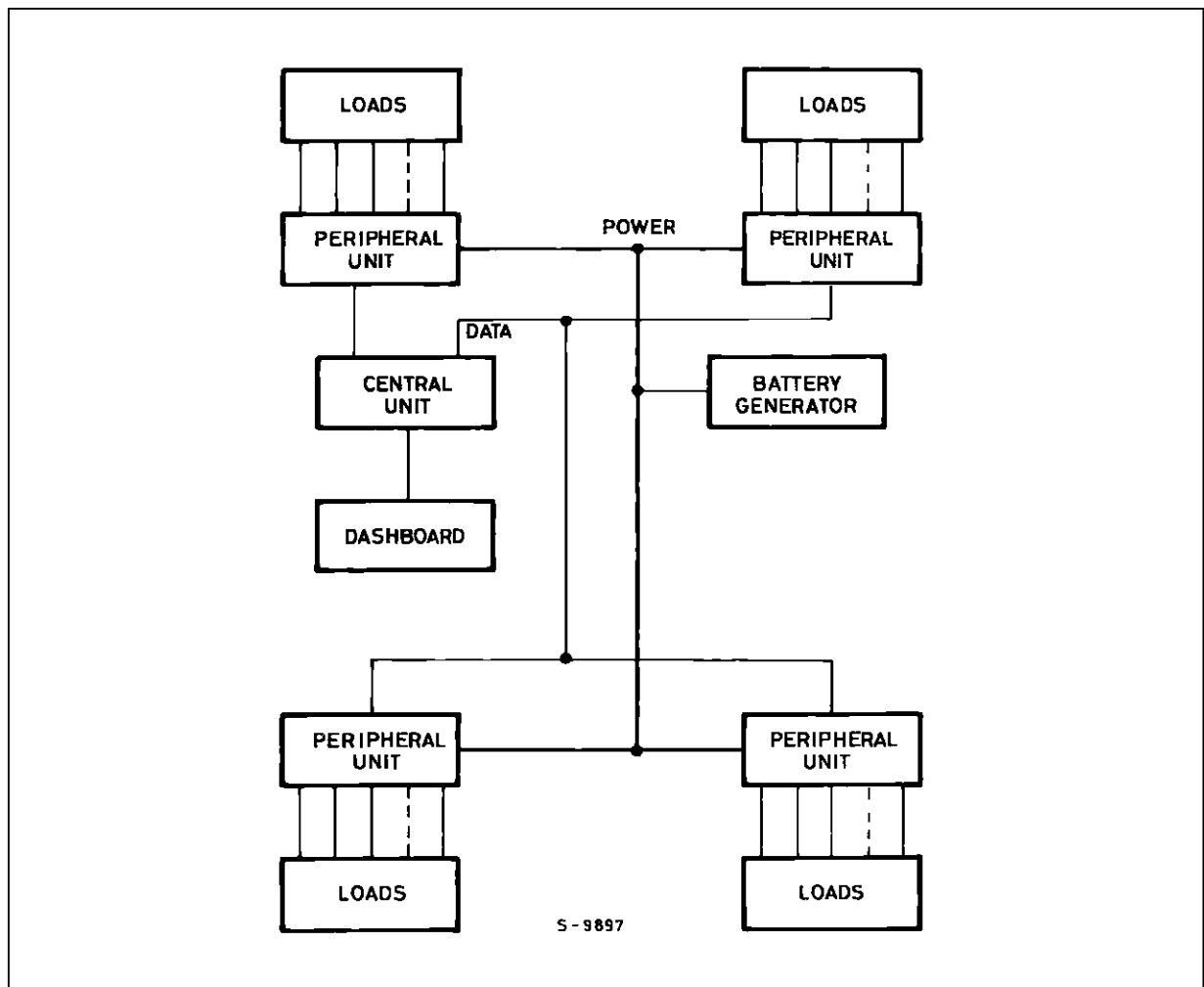

APPLICATION NOTE

The control system is made, for example, with a central unit near the dashboard, for the user interface, a serial data transmission line and some peripheral units near the loads (fig. 2).

The multiplexed system not only makes it possible to reduce weight and overall dimensions of the cable harness, now critical in some places (e.g. the junction between the vehicle body and the doors), but, also makes it possible to have a bidirectional signal between peripheral units and the central unit without any extra line, this is useful for fault detection and, in a future, for data transmission to make a more complex informatic system.

Today the key problem, from the system engineering point of view, is data transmission whereas for

semiconductor technology the key problem is the electronic power switches.

The electronic switch, in addition to its main function, must be able :

- 1) to withstand a very high peak current (20A) with total battery voltage ($\approx 14V$) applied.
- 2) to protect itself, the power network and the load against overvoltages (load dump $\approx 60V$) and overload (protection with fuses is impractical),
- 3) to make some fault detections e.g. detect short circuit or open load condition.

For this reasons a simple electromechanic or electronic switch standing alone is not sufficient, a more

Figure 2 : Block Diagram of a Peripheral Unit.

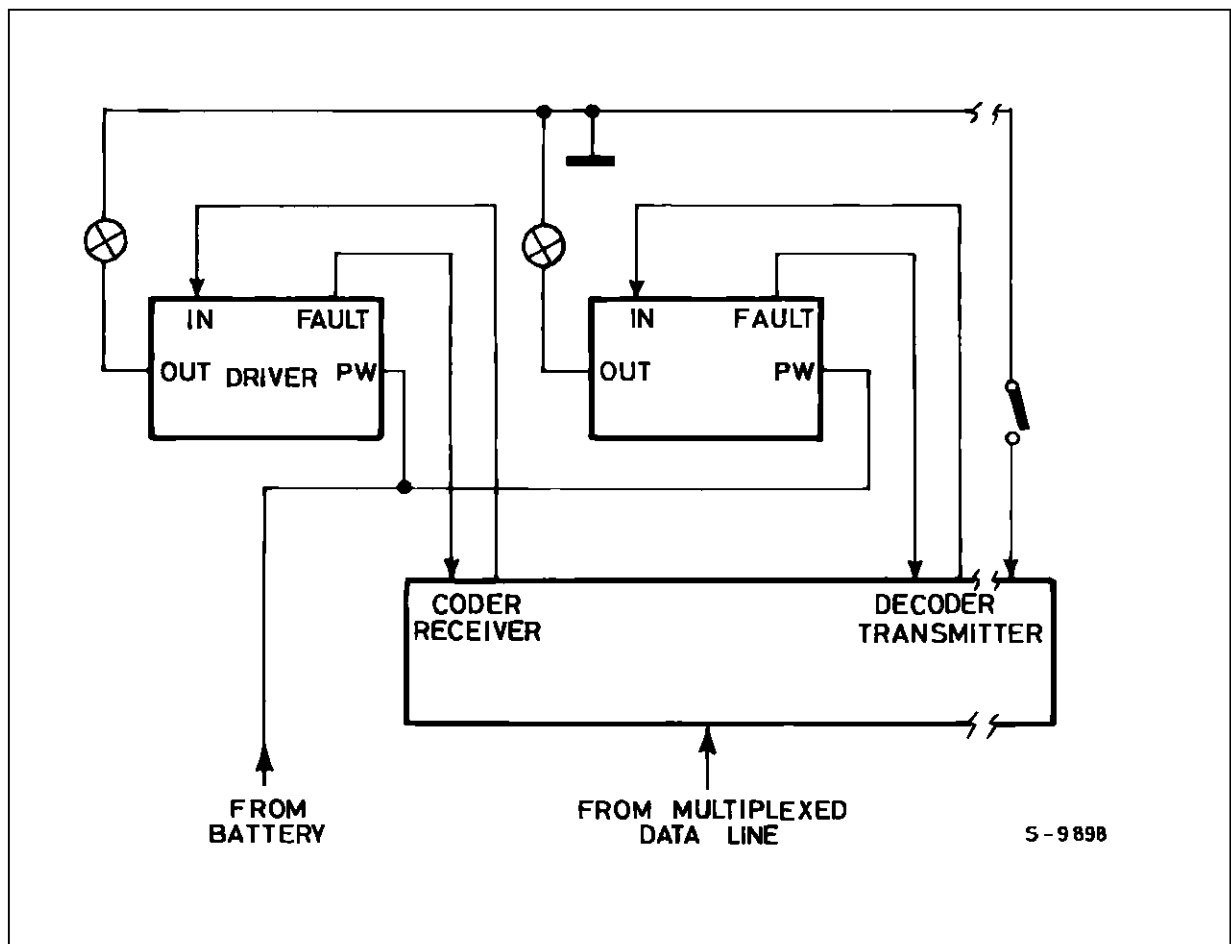

HIGH SIDE DRIVER

The problem of electrochemical corrosion is of primary importance in automotive systems because the electrical components are in an adverse environment (temperature, humidity, salt), for this reason the series switch is connected between the load and the positive power source. Therefore when the electrical component is not powered (that is for the greatest part of the lifetime of the car) it is at the lowest potential and electrochemical corrosion does not take place.

For this connection, components such as power PNP bipolar transistor or Power P-channel MOS would be integrated with low level signal circuitry

(fig. 3a), but this kind of element is less efficient and more difficult to realize than their complementary one. NPN bipolar transistors or N-channel MOS, if directly driven by the supply voltage, are not a good solution because the minimum voltage drop on the switch is V_{BE} or V_T (threshold voltage); the best solution is to have a driving voltage for the power transistor, higher than the positive supply. Nevertheless a power junction NPN transistor (fig. 3b) needs a certain amount of base current ($\beta = 10-60$ to have deep saturation) that could be obtained with a DC-DC converter; if centralized it complicates the power supply distribution network, if decentralized it complicates the peripheral unit always critical for size, reliability and cost.

Figure 3 : Possible High Side Driv-

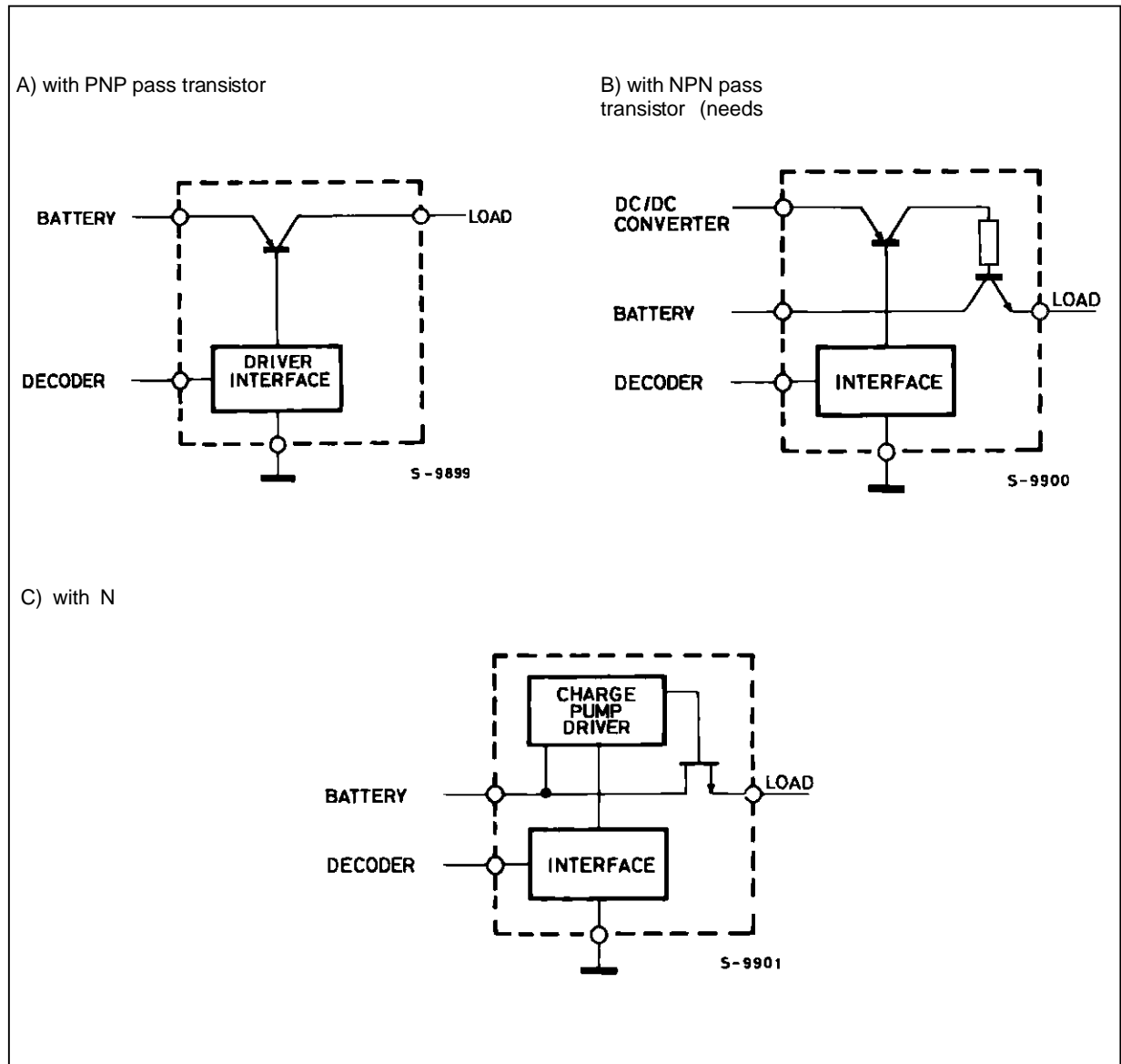

APPLICATION NOTE

On the other side a POWER MOS N-channel (fig. 3c), being a voltage driven device, requires for the driving only a capacitive charge pump which can be fully integrated on the switch chip.

Bipolar transistors moreover need driving power and principally, are limited in maximum peak power by second breakdown.

THE PROCESS TECHNOLOGY

For the realization of the device a mixed Bipolar-CMOS-DMOS process has been utilized. This process integrates the following components (tab.1) (Fig. 4) :

Table 1 : Devices in Multipower-BCD Technology.

VERTICAL D-MOS	$BV_{DSS} > 60V$	$V_{TH} = 3V$	$f_T = 1GHz$
P-CHANNEL DRAIN EXTENSION	$BV_{DSS} > 75V$	$V_{TH} = 1.9V$	$f_T = 200MHz$
C-MOS N-CHANNEL	$BV_{DSS} > 15V$	$V_{TH} = 0.9V$	
C-MOS P-CHANNEL	$BV_{DSS} > 15V$	$V_{TH} = 1.9V$	
BIPOLAR PNP	$V_{CEO} > 20V$	$\beta = 30$	$f_T = 10MHz$
BIPOLAR NPN1	$V_{CEO} > 20V$	$\beta = 30$	$f_T = 300MHz$
BIPOLAR NPN2	$V_{CEO} > 20V$	$\beta = 250$	$f_T = 1GHz$
BIPOLAR NPN3	$V_{CEO} > 20V$	$\beta = 250$	$f_T = 140MHz$

Figure 4 : A Schematic Cross Section of Bipolar, CMOS and DMOS Structures.

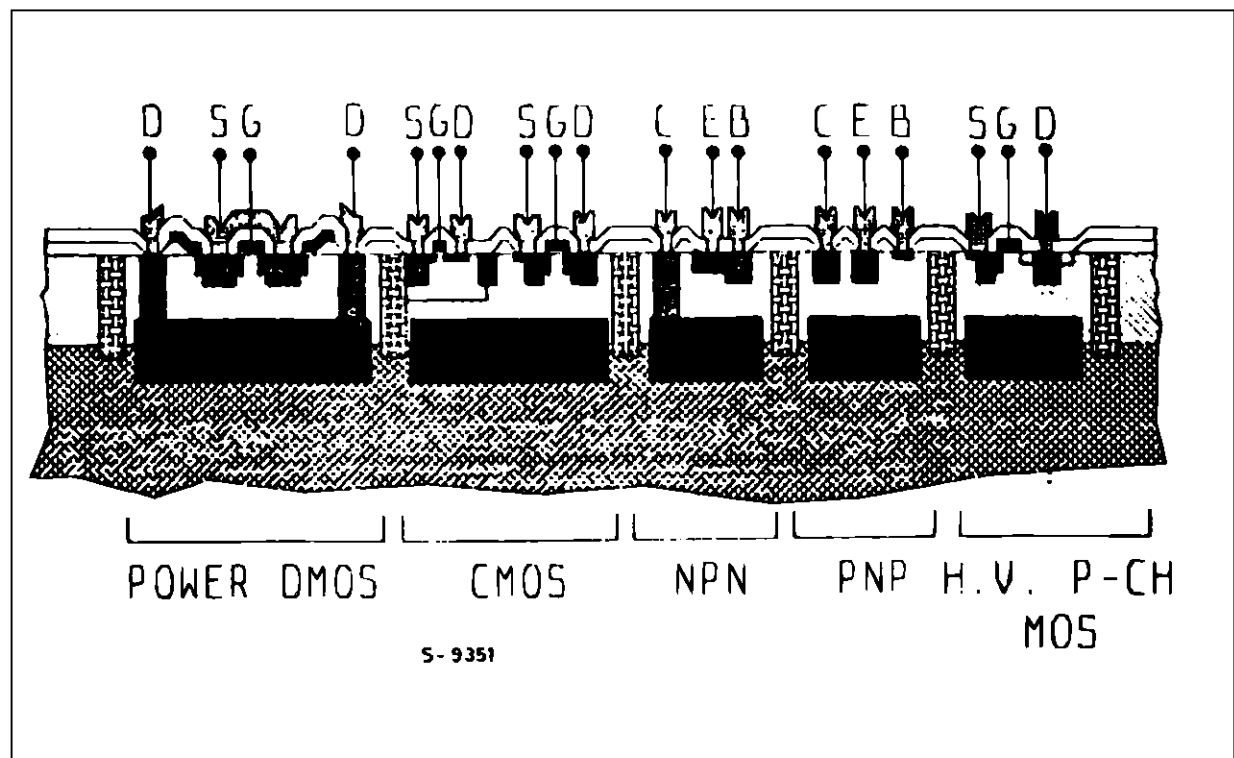

- N-CHANNEL POWER DMOS able to withstand $V_{DS} = 60V$ for the series element.
- BIPOLAR NPN AND PNP TRANSISTORS mainly employed in analog circuitry where low offset and high gain are needed e.g. voltage comparators and references, operational amplifiers.
- CMOS TRANSISTORS to realize a dense logic network with stand by currents practically negligible.
- PASSIVE COMPONENTS as resistors with a great variety of sheet resistivity ($30+8500\Omega/\square$)

to optimize both very high and very low resistive circuitry and gate oxide capacitors (e.g. to realize charge pump capacitors).

THE CIRCUIT

The circuit (fig. 5) is made by a power DMOS series element, a driving circuit with a charge pump, an input logic interface and some protection and fault detection circuits.

Figure 5 : Block Diagram of High Side Switch L9801.

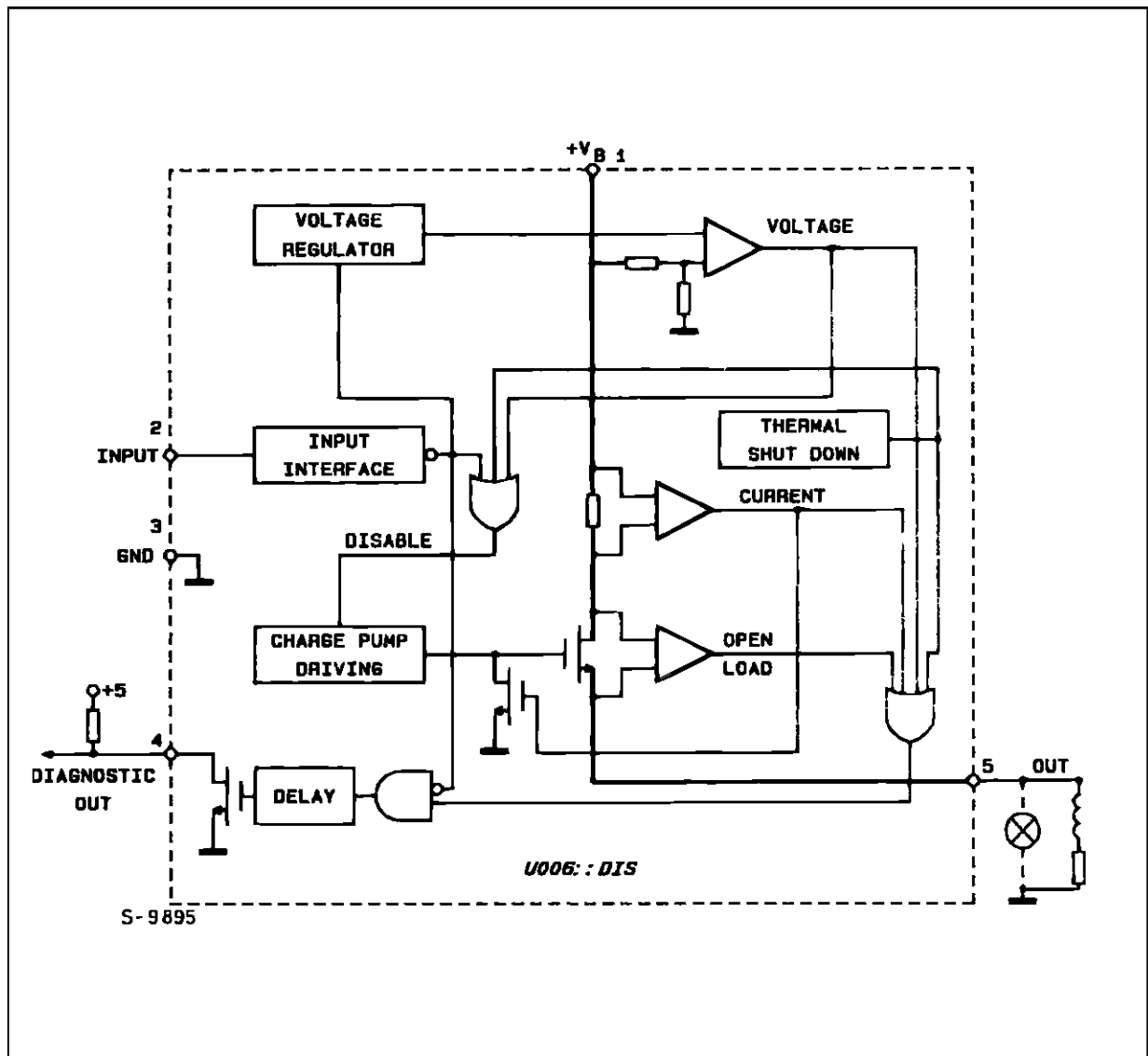

APPLICATION NOTE

THE POWER DMOS

The power DMOS transistor is an array to 10,000 elementary DMOS cells that occupies an area of about 19,000 mils² and has a $R_{DS(on)} = 80m\Omega$ with $V_{GS} = 10V$. The low value of $R_{DS(on)}$ is required both to increase the power transferred to the load and to minimize the power dissipated in the device. In fact the switch must be operative also at very high ambient temperature (125°C) as required in automotive applications. For example to drive a 5A (60W) load, the drop on the switch is 400 mV and the dissipated power is 2W ($R_{th\ j-case} 1.25^{\circ}C/W$).

THE CHARGE PUMP

The charge pump is a capacitive voltage doubler (fig. 6) starting from power supply (car. battery), driven by a 500 KHz oscillator.

The pump capacitor is an integrated 80 pF capacitor, the storage capacitor is the gate capacitance of the power itself (~ 500 pF).

Figure 6 : Charge Pump.

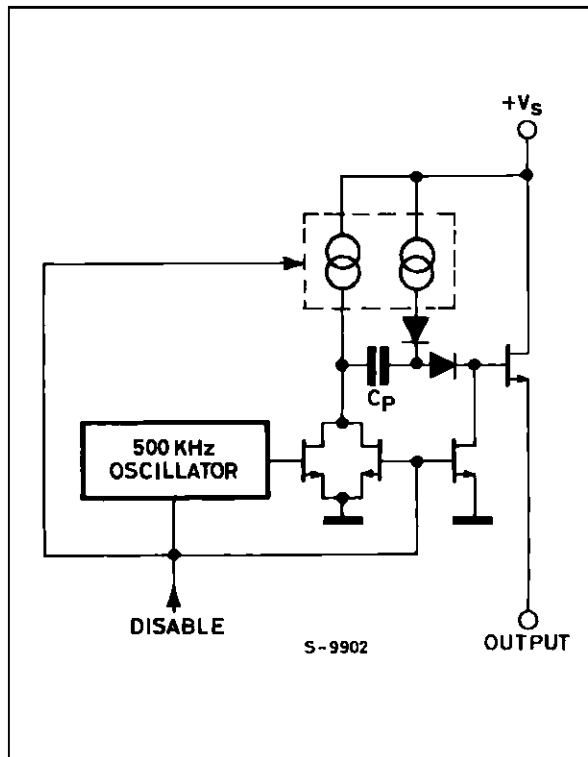

INPUT INTERFACE

Considering the very wide operating temperature range ($T_j = 40$ to $+150^{\circ}C$) it is not possible to obtain the logic threshold from the conduction threshold of any elementary device, because of its temperature coefficient, respecting TTL input levels.

Nevertheless a solution with a voltage reference and comparator is not suitable because it needs a bias current flowing also when the device is in the OFF state.

This point is of great importance because the switches are directly connected to the car battery without the interposition of the ignition switch, thus also a little current ($> 50\mu A$) multiplied for the number of the switches (e.g. 50), causes an appreciable discharge current always flowing.

For this reason a threshold circuit has been designed derived from a well known voltage reference (fig. 7).

Figure 7 : Input Interface.

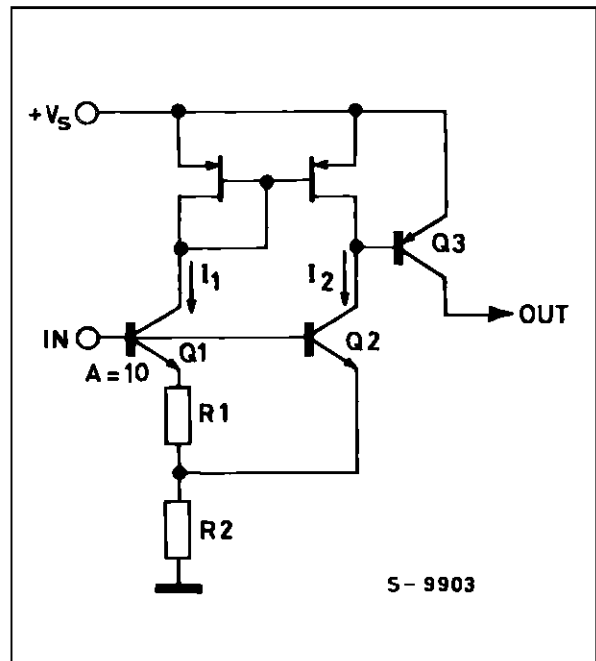

Fixed a threshold value $V_{IN} = V_{IN}^*$ for this value must be, by design $I_1 = I_2 = I_0^*$.

$$\text{if } \alpha = \text{area ratio} \quad \alpha = \frac{A_{Q1}}{A_{Q2}}$$

$$\text{must be} \quad I_1 = \frac{\Delta V_{BE}}{R1}$$

$$(I_1 + I_2) R2 + V_{BE} (Q2) = V_{IN}$$

$$\text{that is } V_{IN}^* = 2 \frac{R2}{R1} \frac{KT}{q} \ln \alpha + V_{BE} Q2$$

Reasoning around the threshold point it can be noted that the transconductance of Q2 is greater than the transconductance in Q1 branch (Q1 series R1).

For this

$$\text{if } V_{IN} > V_{IN}^* \quad I_2 > I_1 \quad Q3 \text{ ON}$$

$$\text{if } V_{IN} < V_{IN}^* \quad I_2 < I_1 \quad Q3 \text{ OFF}$$

The choice of the values is made imposing :

- 1) $V_{IN}^* \equiv V_{BG} \equiv 1.250V$ band-gap voltage of silicon.

In this case V_{IN}^* is practically stable in temperature and centered respect TTL input levels ($V_{LMAX} = 0.8V$. $V_{HMIN} = 2V$).

The idle current I_{ABS} in the worst case, that is when $V_{IN} = V_{LMAX} = 0.8V$. $T_j = 150^\circ C$, it must be $I_{ABS} = I_1 + I_2 < 50\mu A$.

The proposed circuit has also a third working region :
when $V_{IN} < V_{BE}$ $I_{ABS} = 0$ Q3 OFF

Observed that the TTL OUTPUT low level is V_{LMAX} 0.4V with practical driving circuits the idle current of this interface is zero : only at very high junction temperature ($V_{BE} < 400mV$) or with noise margin = V_{BE} 0.4V) this performance cannot be warranted.

The output of this circuit is useful to switch off not only the power DMOS, but also all the other circuits so that the idle current only the one of the input interface.

PROTECTION AGAINST OVERVOLTAGES

When the supply reaches the maximum operative voltage (18V) the device is turned OFF, protecting itself and the load ; moreover local zener clamps are provided in some critical points to avoid that V_{GS} of any MOS transistor could reach dangerous values even during 60V load-dump transistor.

PROTECTION AGAINST OVERLOAD

If the design of this device the peculiar inrush current of incandescent lamps must be considered, in fact.

- 1) When the tungsten wire is cold its resistance is about one tenth of the nominal steady state value (e.g. about $300m\Omega$ for a 12V/50V lamp).
- 2) The decay time constant for the turn on extra-current of an incandescent lamp supplied with an ideal voltage source is on the order of some milliseconds.
- 3) A lamp powered with a constant current slightly higher than its steady state value has a turn on time on the order of 100msec. This time comparable with human reaction time is too much long for all flash-signalling devices.

The design choice has been to put a 20A current limit (that is $I_{max} = 5 I_{nom}$ for a 50W/12V rated lamp). This is a compromise between lamp turn on time

(40msec) and electric and thermal dimensioning of the device (fig. 8).

If the high current condition persists (e.g. load short circuit) and the junction temperature rises above $155^\circ C$ a thermal protection circuit turns off the device preventing any damage.

It must be noted that the power DMOS has no second breakdown, for this reason current limiting and thermal shutdown are sufficient to protect the device against any overload.

Some thermal hysteresis is provided to avoid a potentially critical condition (both current and voltage present during thermal shut down) for the POWER MOS.

Figure 8 : Lamp Current (I_L) and Voltage (V_L) vs. Time with 20A Current Limitation and 12V/50W Lamp.

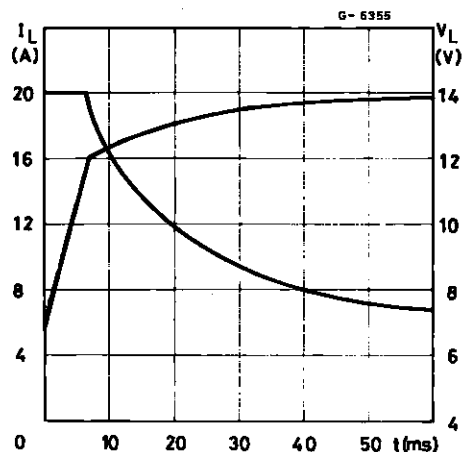

FAULT DETECTION

When the device is driven and one of the protections (over temperature, overvoltage, overload) is present a fault detection open drain output turns-on. This output is active also when the drop on the POWER MOS is less than 80mV (that is $I_{load} < 1A$) detecting the open load (disconnected or burned-out).

When the device is off the fault detection circuits are not active and output transistor is turned off to allow a minimum quiescent current.

MOTOR AND INDUCTIVE DRIVING

This device can drive unipolar DC motors and solenoids as well, in fact it can recirculate an inductive current when the output voltage goes more than a threshold lower than ground. The possibility to have a high start-up current is useful also for DC motors.

CONCLUSION - FUTURE DEVELOPMENTS

A process allowing the integration of power DMOS, CMOS and BIPOLAR transistor makes possible the construction of a monolithic switch comprehending also protection and fault detection functions.

The power DMOS approach allows also the possibility to make a large range of power switches with different ON resistance and current capability only scaling proportionally the power area.

Moreover the CMOS structures can be utilized to make also the coder/decoder circuit to interface directly the transmission line.

Those features and the possibility to integrate more than one power element on the same chip makes possible, in a near future, the integration of the whole peripheral unit.

Information furnished is believed to be accurate and reliable. However, SGS-THOMSON Microelectronics assumes no responsibility for the consequences of use of such information nor for any infringement of patents or other rights of third parties which may result from its use. No license is granted by implication or otherwise under any patent or patent rights of SGS-THOMSON Microelectronics. Specifications mentioned in this publication are subject to change without notice. This publication supersedes and replaces all information previously supplied. SGS-THOMSON Microelectronics products are not authorized for use as critical components in life support devices or systems without express written approval of SGS-THOMSON Microelectronics.

© 1995 SGS-THOMSON Microelectronics All Rights Reserved

SGS-THOMSON Microelectronics GROUP OF COMPANIES

Australia - Brazil - France - Germany - Hong Kong - Italy - Japan - Korea - Malaysia - Malta - Morocco - The Netherlands - Singapore - Spain - Sweden - Switzerland - Taiwan - Thailand - United Kingdom - U.S.A.



LittleDiode supplies new, hard to find or obsolete electronic components and semiconductors all over the world.

With over two million different components listed you are sure to find the part you need.

Feel free to visit us today at our online store:

LittleDiode.com

Looking forward to providing you with the best possible service.