

## LATCHING CURRENT

By E. LEBLANC

An important problem concerning the utilization of components such as thyristors or triacs is the holding of the component in the conducting state after the trigger current has disappeared during firing. Very often, the firing problems supposedly due to the gate current  $I_G$  or to the firing time  $t_{GT}$  are in reality due to the latching current  $I_L$ .

After a definition we will illustrate the importance of this parameter by concrete examples. Then we will describe how to measure it and its variation according to the utilization conditions of the components.

The study will be based on the triac. The points treated are valid for thyristors (except for the various conduction modes).

### DEFINITION

The latching current,  $I_L$ , of a triac is the minimum value of the main current (current flowing between electrodes  $A_2$  and  $A_1$ ) which enables the component to remain in the conducting state after the gate current  $I_G$  has ceased (*Figure 1*).

**Figure 1** : Controlled by the gate pulse,  $I_G$ , the triac is fired, and a current  $I_T$  flows through it, imposed by the main current. If the gate current  $I_G$  is stopped before current  $I_T$  reaches the value of the latching current  $I_L$ , the triac is blocked (as shown in the figure).

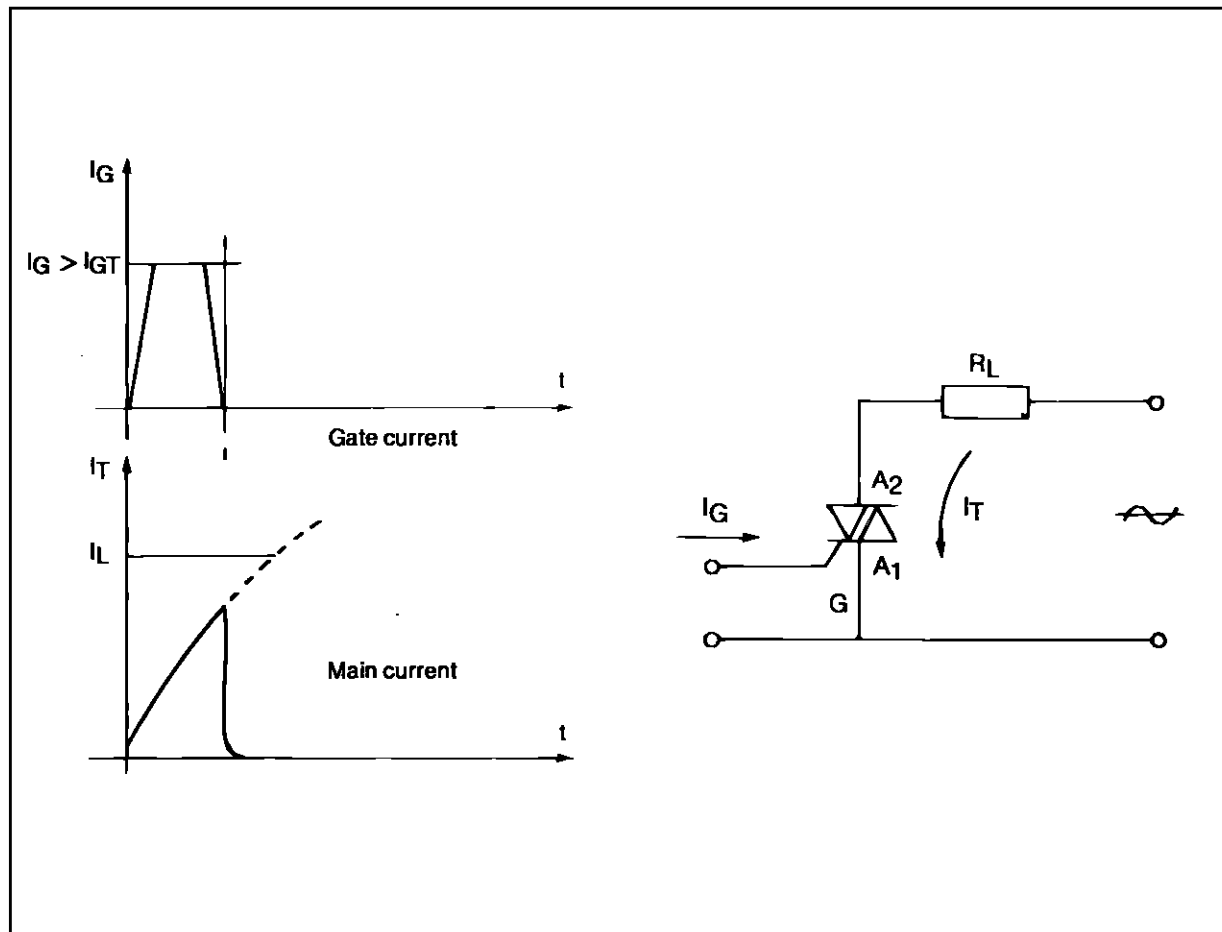

## APPLICATIONS

**Example 1 :** Control of a low power signalling lamp by triac.

**Figure 2 :** Control of a Low Power Signalling Lamp by Triac.

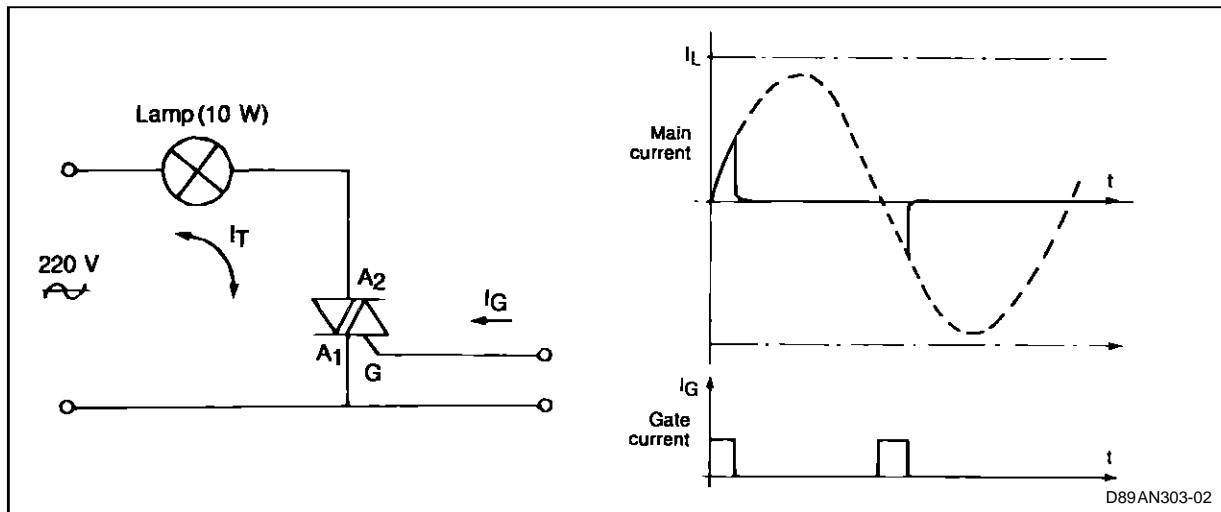

Current in the main circuit of the triac and gate current. The lamp power is too low (eg. :  $P \leq 10$  W and the triac BTA 12.400B) to impose a sufficient current (shown in dotted lines in the diagram) in the triac to keep it in the conducting state after interruption of the gate current  $I_G$ . The triac does not conduct.

A BTA 12.400 B triac is used to control the flashing of a 10 W signalling light. The peak current in the circuit

will therefore be 65 mA. This value is very close to that of the typical latching current given in the data book for this type of triac : 50 mA (quadrant 1, 3 and 4). Thus the user's case could be that described in figure 2, that is, a triac whose latching current  $I_L$  in the first quadrant is equal to 70 mA. His triac will never be fired. For correct operation, the user should thus employ a sensitive triac (e.g. Z0102MA  $I_L$  : 8 mA).

**Example 2 :** Control of an inductive load by triac.

**Figure 3 :** Voltage Across and Current Through the Triac.

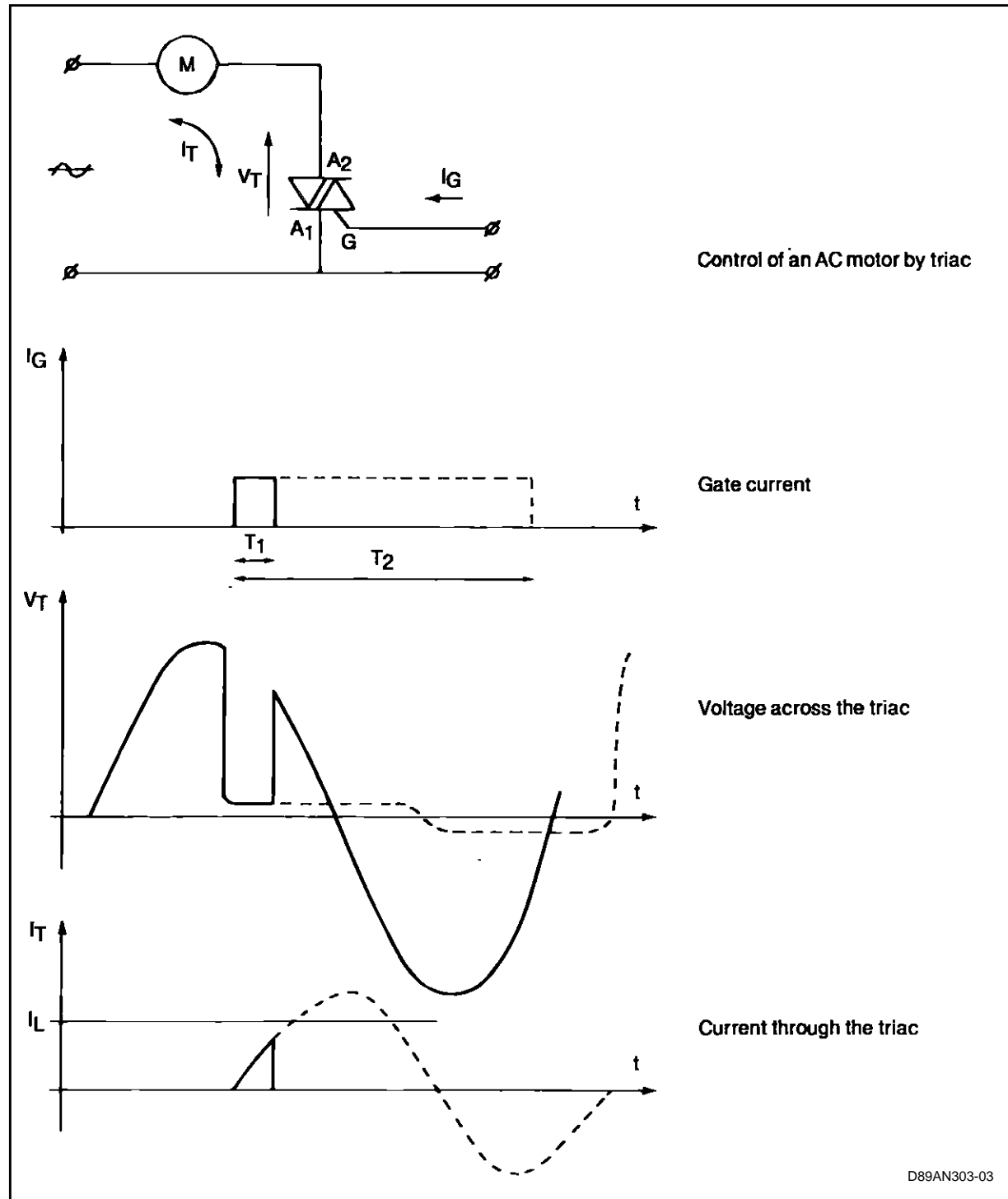

**In continuous lines :** short gate signal : the triac does not remain in the conducting state because the main current did not reach the value of the triac latching current before suppression of the gate current.

**In dotted lines :** long gate signal : the triac is fired and remains in the conducting state until its current falls below the holding current  $I_H$  after suppression of the gate current  $I_G$ .

On a highly inductive load, the inductance limits the current rise time to :

$$\frac{dI_T}{dt} = \frac{V_a}{L}$$

( $V_a$  : power supply voltage at the time the gate signal is applied ;  $L$  : load inductance).

Consider the operation on one full-wave of the power supply voltage. If the duration  $t_1$  of the gate current pulse  $I_G$  is very small compared with a half-wave of the power supply voltage, the triac current cannot reach the triac latching current level in the firing mode considered (here the 1st quadrant). Thus firing will not take place and the voltage across

the triac increases. For triggering to be steady, the duration of pulse  $t_2$  should be long when compared with a half-wave of the power supply voltage. The current set up in the triac is imposed by the load impedance. The triac remains in the conducting state until the current falls below the holding current  $I_H$ . It is blocked if the  $I_G$  current pulse has ended.

Another method consists of applying a train of closely spaced pulses to the triac gate instead of a square wave.

The SGS-THOMSON Microelectronics applications laboratories have developed a number of triac control circuits, specially designed to work on inductive loads (see bibliography, ref. N° 1).

**Example 3 :** Control by triac of a load whose power varies considerably.

**Figure 4 :** Control of an Arc Welding Set by Triac.

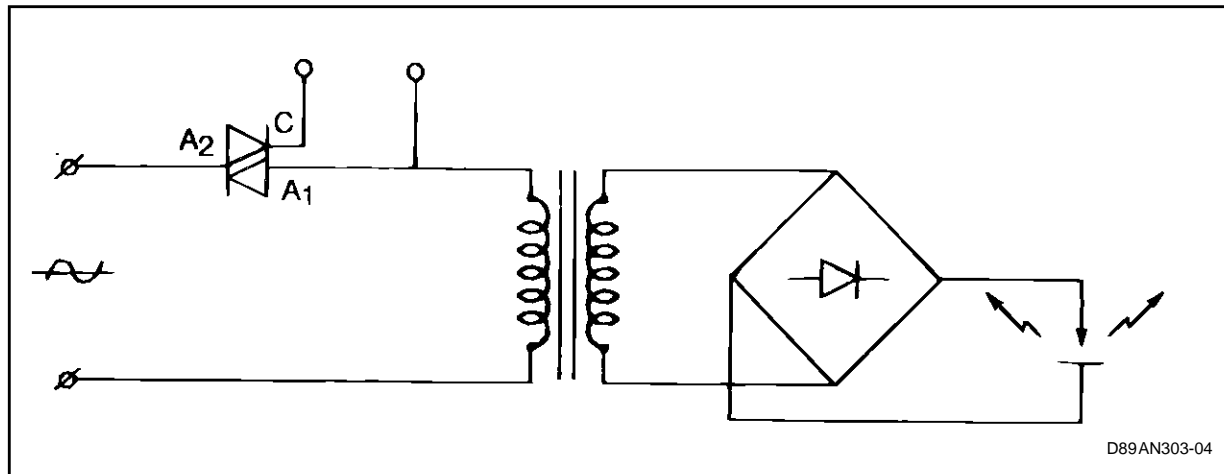

The designer of an arc welding set whose power is adjustable by triac, chooses a component capable of controlling high currents. For example, if the maximum current to be controlled is  $40 A_{rms}$ , the designer, for safety, will choose a triac rated at  $60 A_{rms}$ , thus a triac with a high latching current. Now, off-load, the transformer magnetizing current could be very low or even below the triac latching current  $I_L$  in one of the quadrants. This means that the triac could fire correctly in the first quadrant and then not fire if the next firing is to take place in the second quadrant where the  $I_L$  is much higher. A considerable unbalance then occurs, generating a DC current heating the transformer and preventing the equipment from operating correctly.

Since the latching current  $I_L$  increases with the size

of components, and thus with their rating, the user would thus be well advised not to select an excessively high rating for his triac in order to have the lowest possible latching current.

A.N : For this type of application, the SGS-THOMSON Microelectronics applications laboratories place at the disposal of designers a number of schematics meant for this type of circuit (see bibliography, ref. N°1).

These three examples illustrate the importance of the  $I_L$  parameter and the problems that it can cause in a circuit. To ensure stable firing of a triac or a thyristor, it is absolutely necessary for the circuit which is controlled to impose a current which is higher than its latching current.

### FAVORABLE EFFECT OF AN RC CIRCUIT ON THE FIRING OF A THYRISTOR OR A TRIAC

In most inductive load applications of triacs or thyristors, the user connects an RC network between the anode and cathode of the device to eliminate the

risk of premature firing by transients or spontaneous firing by  $(dv/dt)_c$  (case of triacs) (see figure 5). Capacitance C and the load impedance attenuate steep voltage transients transmitted by the mains or resulting from switching inductive loads.

**Figure 5 :** Reducing the Risk of Untimely Firing on Inductive Loads : the RC Circuit (called « Snubber »).

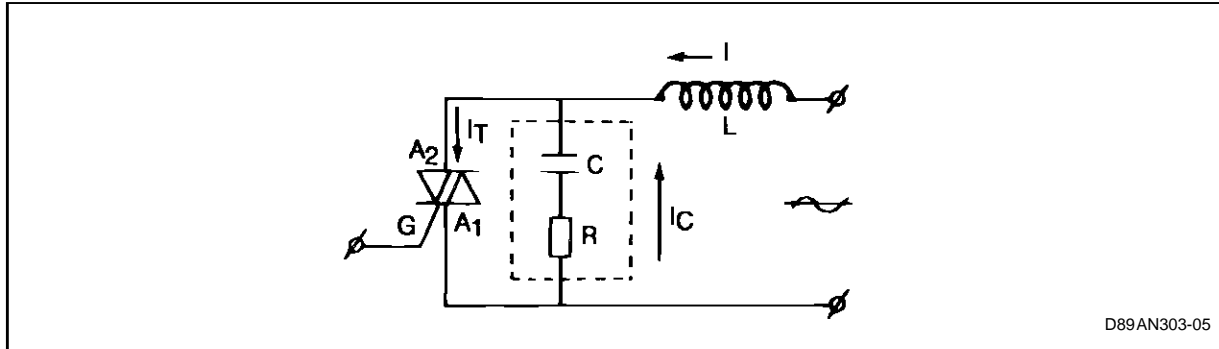

This RC network has also a second advantage. In fact, the energy accumulated in capacitor C after turning off is fed back to the triac when firing. The speed at which the current increases in the triac during discharge of the capacitor is then limited only by the peak charge voltage of the capacitor and the inductance

of the circuit connecting the SNUBBER to the triac. The current amplitude is the quotient of peak charge voltage of the capacitor by the series resistance R. This circuit thus helps the current to rise very quickly above the latching current  $I_L$  of the device (see figure 6).

**Figure 6 :** Favorable Effect of the RC Circuit for Firing on a Highly Inductive Load.

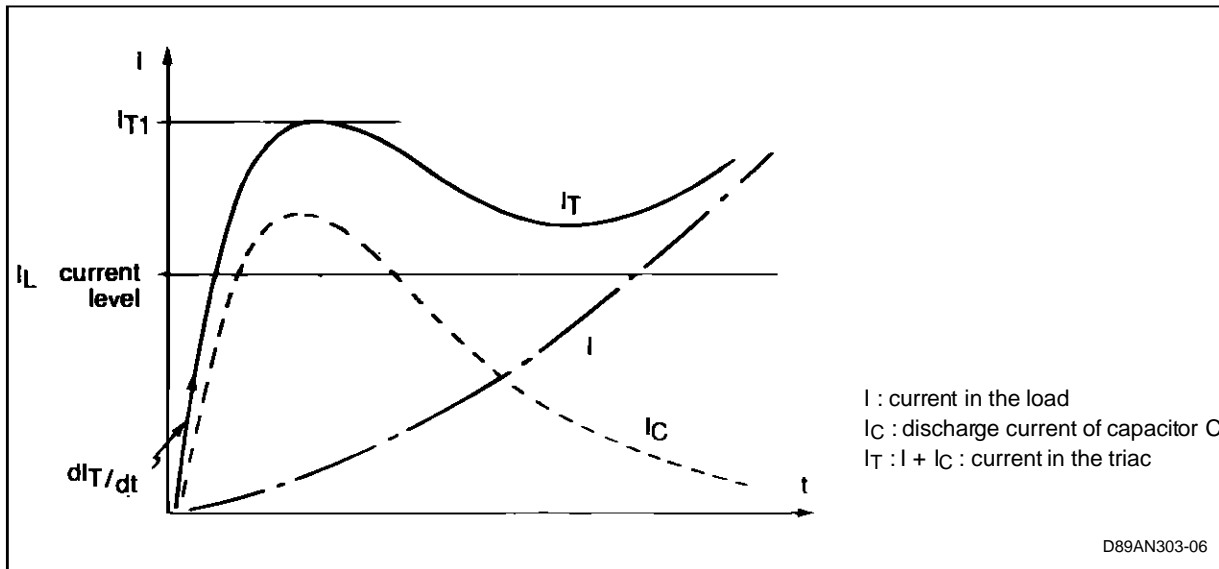

**Note :** When using an RC circuit, it is not advisable to work with a series resistance R which is too low. In fact, the combined effect during firing of  $I_{T1}$  (figure 6) (equal to the quotient of the capacitor peak charge voltage and resistance R) and the current slope  $dI_T/dt$  (equal to the quotient of the capacitance charging voltage by the inductance of the connection between the triac and the RC circuit) could be dangerous for the triac. A value for R higher than 100 ohms is recommended.

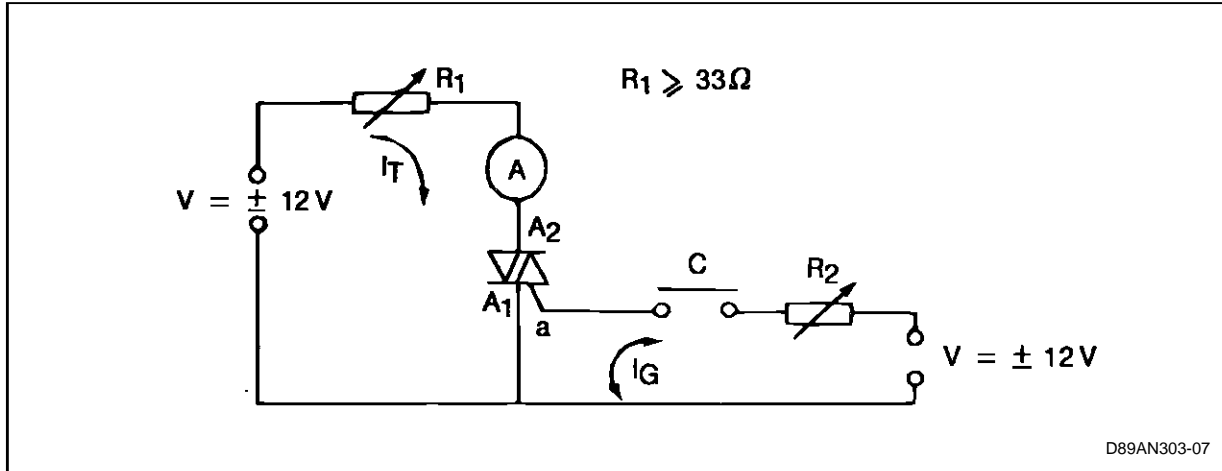
LATCHING CURRENT ( $I_L$ ) MEASUREMENTFigure 7 : Latching Current ( $I_L$ ) Measurement Circuit.

The closing of contact C enables passage of the gate current whose is selected higher than that of the triac firing current,  $I_{GT}$  to be measured. By gradually decreasing the value of resistance  $R_1$ , while continuing to transmit pulses of gate current  $I_G$ , the main current  $I_T$  is increased. As long as the value of the  $I_T$  current is lower than that of the device latching current  $I_L$ , the device does not remain in the conducting state. The value of the latching current  $I_L$  is the value of the  $I_T$  current read as soon as the triac remains on, after suppressing the gate current  $I_G$ .

Only sensitive thyristors ( $I_{GT} \leq 500 \mu A$ ) are measured with a  $1 K\Omega$  resistor between gate and cathode.

Parameter  $I_L$  varies with the width of the gate current pulse  $I_{GT}$  and its level. For the measurement to be reproduced correctly, the following rules should thus be observed :

Fix a sufficiently wide control pulse  $I_G$ . The width of the pulse should be at least equal to 1 ms.

Impose a gate current  $I_G$  sufficiently high with respect to that of the triggering current  $I_{GT}$  of the device to be measured.

An  $\frac{I_G}{I_{GT}}$  ratio higher than or equal to 1.2 is advisable.

**Example :** BTA 12.600 C

$I_{GT \max (Q IV)} = 50 \text{ mA}$  therefore

$I_G = 60 \text{ mA}$

In the case of a triac, there are four latching current  $I_L$  values that correspond to the four quadrants of triac operation :

- ( $I_L + +$ ) when the electrodes  $A_2$  and G are positive with respect to electrode  $A_1$ .

- ( $I_L + -$ ) when electrode  $A_2$  is positive with respect to electrode  $A_1$  and electrode G is negative with respect to electrode  $A_1$ .

- ( $I_L - -$ ) when electrodes  $A_2$  and G are negative with respect to electrode  $A_1$ .

- ( $I_L - +$ ) when electrode  $A_2$  is negative with respect to electrode  $A_1$  and electrode G is positive with respect to electrode  $A_1$ .

## VARIATIONS OF LATCHING CURRENT $I_L$ WITH THE UTILIZATION CONDITIONS

a) Variations of the  $I_L$  current with sensitivity of triacs and the various directions of conduction (typical values).

For the low power components (thyristors and triacs whose rated current is lower than 60A) the latching current  $I_L$  is dependent on the value of firing current  $I_{GT}$  (see figure 8).

**Figure 8** : Ratio of the Latching Current  $I_L$  in the Different Quadrants to the Triggering Current  $I_{GT}$  in the First Quadrant, for Sensitive and Standard Triacs (typical values).

	$\frac{I_L(QI)}{I_{GT}(QI)}$	$\frac{I_L(QII)}{I_{GT}(QI)}$	$\frac{I_L(QIII)}{I_{GT}(QI)}$	$\frac{I_L(QIV)}{I_{GT}(QI)}$
6 A <sub>rms</sub> Sensitive Triacs	3.5	15	5	3
12 A <sub>rms</sub> Standard Triacs	2	5	1.5	1.7

**Example 1** : BTA 06.600 T : if  $I_{GT}(QI) = 1$  mA  
then :  $I_L(QI) \approx 3.5$  mA ;  
 $I_L(QII) \approx 15$  mA  
 $I_L(QIII) \approx 5$  mA ;  
 $I_L(QIV) \approx 3$  mA

**Example 2** : BTA 12.600 C :  $I_L$  typ = 40 mA QI, III, IV  
 $I_L$  typ = 70 mA QII

Depending on the production batches, parameter  $I_L$  shows dispersion. Shown below are approximate values :

and BTA 12.600 Bif  $I_{GT}(QI) = 15$  mA  
then :  $I_L(QI) \approx 30$  mA ;  
 $I_L(QII) \approx 75$  mA  
 $I_L(QIII) \approx 22$  mA ;  
 $I_L(QIV) \approx 25$  mA

- sensitive triacs :  
 $I_{GT}(QI) \leq 5$  mA (type T): QI, III, IV :  $2 \text{ mA} \leq I_L \leq 8 \text{ mA}$   
QII :  $10 \text{ mA} \leq I_L \leq 40 \text{ mA}$

- standard triacs :  
 $I_{GT}(QI) \leq 50$  mA (type B): QI, III, IV :  $15 \text{ mA} \leq I_L \leq 50 \text{ mA}$   
QII :  $50 \text{ mA} \leq I_L \leq 120 \text{ mA}$

In the case of triacs, as opposed to that of thyristors, note that : as underlined in the table of figure 8, the current  $I_L + -$  (electrode  $A_2$  positive with respect to electrode  $A_1$  and electrode G negative with respect to electrode  $A_1 - QII$ ) is much higher than the  $I_L$  current in the three other quadrants.

In the data sheets two values are specified : one value for quadrants I, III and IV and one value for quadrant II. In general these values are typical.

## b) Relation between the latching current $I_L$ and the holding current $I_H$

The holding current value  $I_H$  (see bibliography, note N° 2) is linked to the latching current value,  $I_L$ . By definition, the  $I_L$  current value will always be higher than the  $I_H$  current value.

The  $I_L / I_H$  ratio varies following the sensitivity of the triacs and their ratings (see figure 9).

**Figure 9** : Ratio of the Latching Current  $I_L$  to the Holding Current  $I_H$  Depending on the Sensitivity and Ratings of the Devices (typical values).

	Sensitive Triacs and Thyristors $I_{RMS} \leq 6$ A	Medium Power Thyristors and Triacs $6$ A $\leq I_{RMS} \leq 60$ A	High Power Thyristors and Triacs $60$ A $\leq I_{RMS} \leq 300$ A
$I_L / I_H$ (1)	1.1 to 1.5	1.5 to 2	2 to 5

(1) 1 st quadrant in the case of triacs.

**c) Variations of the latching current  $I_L$  with the junction temperature.**

The value of the latching current  $I_L$  is physically lin-

ked that of the triggering current  $I_{GT}$ . These two parameters therefore vary analogously with the junction temperature (see figure 10).

**Figure 10 :** Relative variations of the latching current  $i$  versus the junction temperature  $t_j$  (typ. values).

- 1. Quadrant 2
- 2. Quadrants 1, 3 and 4.

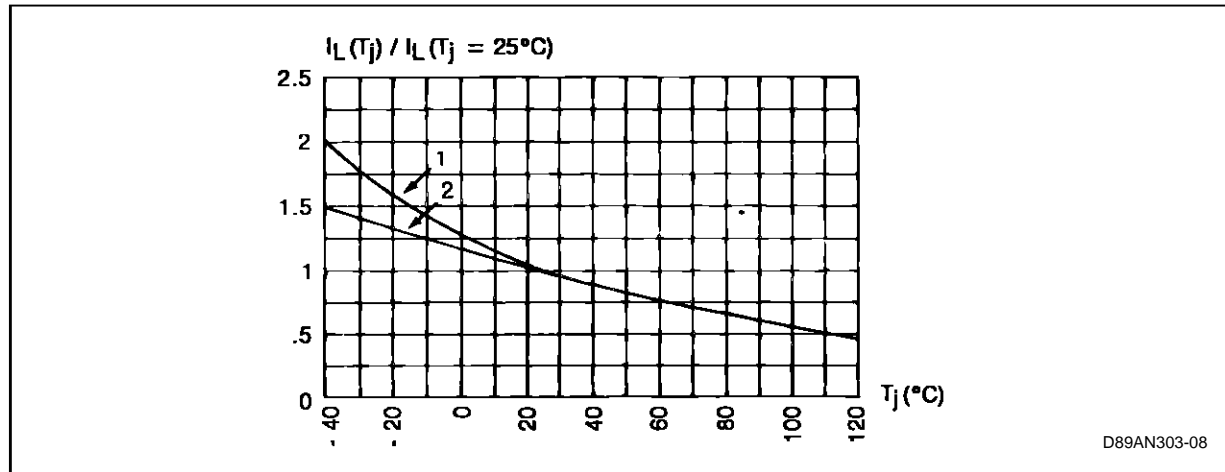

**Example 3 :** Triac TO 220, type BTA 12.600 C  
 If  $I_L(QI) = 20$  mA at  $T_j = 25$  °C, then  $I_L(QI) = 30$  mA at  $T_j = -40$  °C

This resistor affects the value of the latching current  $I_L$  in different proportions depending on its resistive value and the sensitivity of the component.

**d) Influence of the external gate-cathode resistor  $R_{GC}$**

- 1. Sensitive thyristors ( $I_{GT} < 500$   $\mu$ A)

When using sensitive thyristors, the designer could wire a resistor  $R_{GC}$  between cathode and gate to improve their voltage capability at high temperatures (shunting of leakage currents).

Resistor  $R_{GC}$  connected between gate and cathode (figure 11) has an important influence on the latching current  $I_L$  of sensitive thyristors. For some applications, the designer would be well advised to define a high impedance triggering circuit.

**Figure 11 :** Variation of the latching current  $I_L$  of a sensitive thyristor (e. g. TLS106-6) as a function of the gate-cathode resistance  $R_{GC}$  (typ. values).

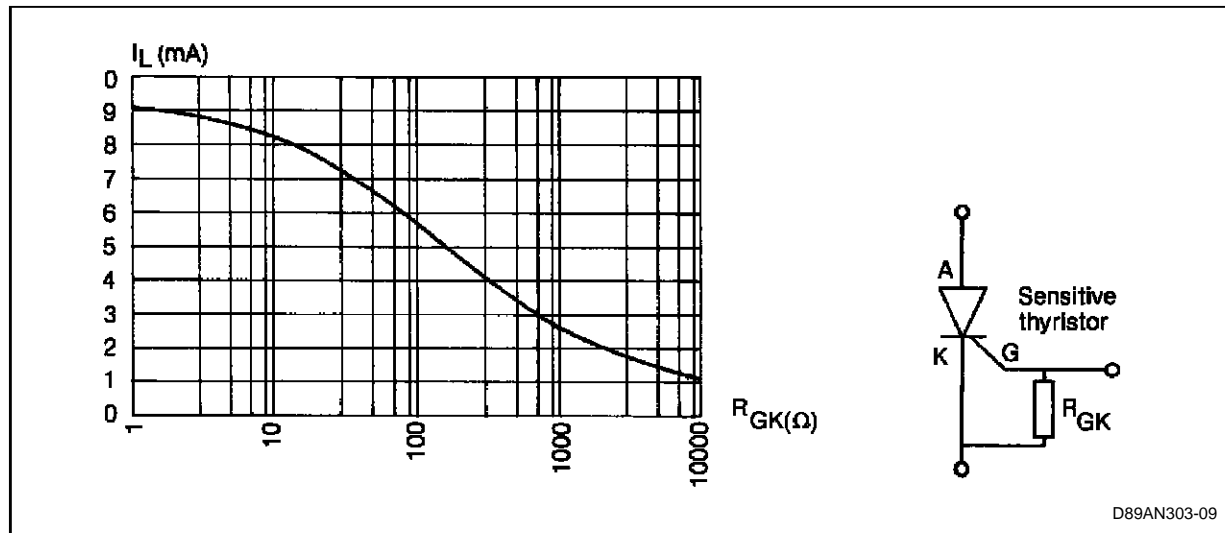

**Note :** The latching current of sensitive thyristors is always specified with a 1000-ohm gate-cathode resistor.

2. Standard thyristors, sensitive and standard triacs  
 A resistor connected between the gate and cathode of one of these components does not have a significant influence on the value of its latching current  $I_L$  (on condition that its value is not too low  $R_{GC} > 20$  ohms).

**e) Variation of the latching current  $I_L$  with the control conditions**

The latching current  $I_L$  of a triac or a thyristor rated at less than 60  $A_{rms}$  varies with the amplitude and

the width of the triggering pulse  $I_G$ . With a constant pulse width ( $< 50 \mu s$ ), an increase in the amplitude of  $I_G$  will lead to an increase in the latching current  $I_L$  and vice versa, if the amplitude of  $I_G$  is kept constant, a decrease in the width of the triggering pulse will lead to an increase in the latching current  $I_L$  that can even lead to an absence of firing of the device (figure 12).

**Figure 12 :** Variation of the Latching Current  $I_L$  versus the Width  $t_p$  and the Level of the Gate Current  $I_G$  (represented here as a multiple of the triggering current  $I_{GT}$  of the triac under consideration) Triac BTB 16.600 B (quadrant 1) (typical values).

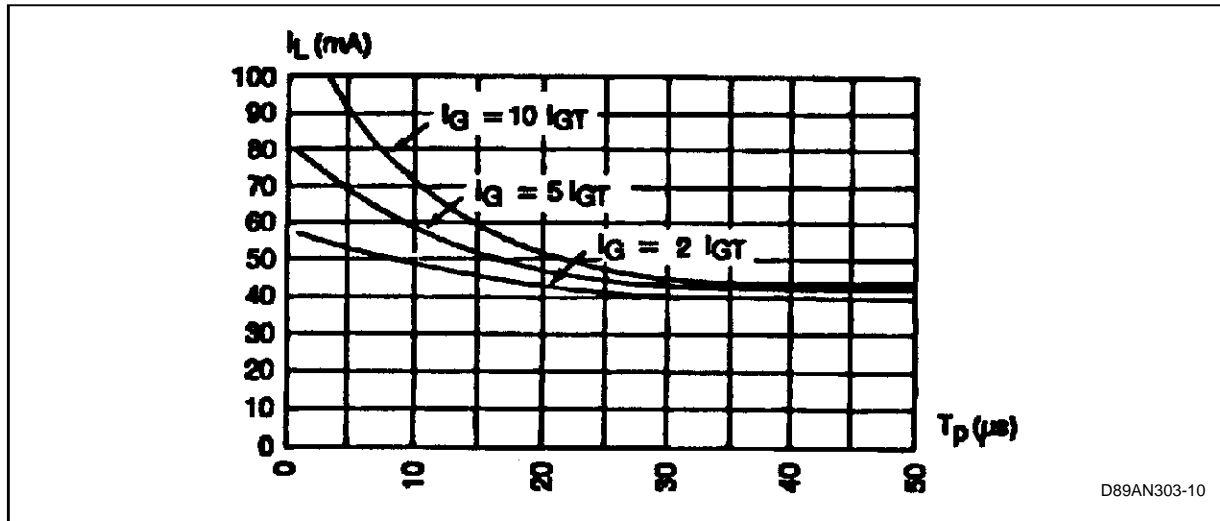

Negative biasing of the gate circuit (example : shape of the pulse in figure 13a) increases the latching current  $I_L$  in considerable proportions. If the decreasing speed  $dI_G/dt$  of the gate current is low

(example: pulse shape of figure 13 b) (less than  $0.5 A/\mu s$ ) the value of the latching current approaches the holding current  $I_H$ .

**Figure 13a :** Gate Current Pulse with Negative Current at the end of the Pulse : Increase of the Latching Current  $I_L$ .

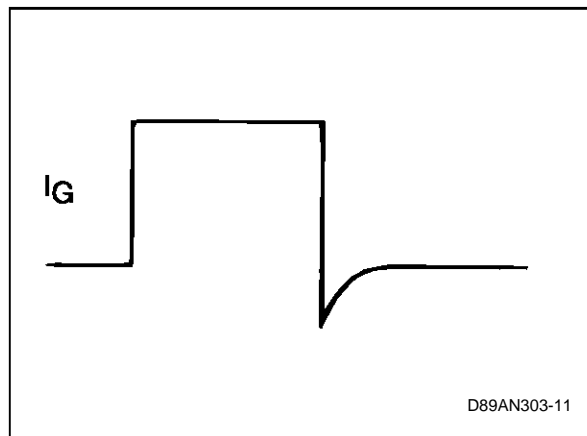

**Figure 13b :** Gate Current Pulse (diac controlled type) with tailing and without Negative Current : decrease of the Latching Current  $I_L$ .

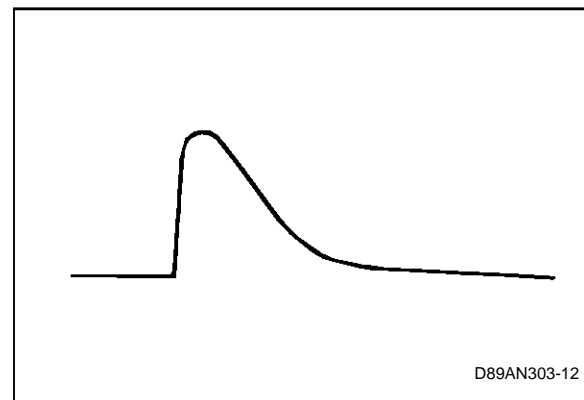

In order to obtain the lowest possible values for the latching current  $I_L$ , and thus ensure correct firing of the device, it is advisable to work with an amplitude of  $I_G$  equal to  $1.2 I_{GT}$  and a width of the control current as high as possible. The firing technique using trains of closely spaced pulses ensures stable firing in total security. Control pulses with smooth tailing edges and without reverse current allow reducing the latching current.

### CONCLUSION

The choice of a thyristor or of a triac does not depend only on the rated current, voltage and sensitivity. Other parameters also play an important part in the correct operation of a circuit and should be taken into account. The latching current  $I_L$  is one of these. Its value varies with :

- the way in which the device is controlled (shape of the gate pulse)
- the temperature
- the trigger circuit (case of sensitive thyristors)
- the direction of the current.

Triac and thyristor applications involving highly in-

ductive loads or loads with considerable variations of controlled power are the main applications where the latching current  $I_L$  plays a determining role.

Taking these elements into account will enable the designer to obtain satisfactory operation of his circuit in industrial applications.

### BIBLIOGRAPHIE

1 - "Control of triacs for inductive loads" : technical information TI 36 / SGS THOMSON MICROELECTRONICS by X. DURBECQ.

2 - "Hypostatic current or holding current" by E. LEBLANC.

Information furnished is believed to be accurate and reliable. However, SGS-THOMSON Microelectronics assumes no responsibility for the consequences of use of such information nor for any infringement of patents or other rights of third parties which may result from its use. No license is granted by implication or otherwise under any patent or patent rights of SGS-THOMSON Microelectronics. Specifications mentioned in this publication are subject to change without notice. This publication supersedes and replaces all information previously supplied.

SGS-THOMSON Microelectronics products are not authorized for use as critical components in life support devices or systems without express written approval of SGS-THOMSON Microelectronics.

© 1995 SGS-THOMSON Microelectronics - Printed in Italy - All rights reserved.

SGS-THOMSON Microelectronics GROUP OF COMPANIES

Australia - Brazil - France - Germany - Hong Kong - Italy - Japan - Korea - Malaysia - Malta - Morocco -  
The Netherlands - Singapore - Spain - Sweden - Switzerland - Taiwan - Thailand - United Kingdom - U.S.A.



LittleDiode supplies new, hard to find or obsolete electronic components and semiconductors all over the world.

With over two million different components listed you are sure to find the part you need.

Feel free to visit us today at our online store:

[LittleDiode.com](http://LittleDiode.com)

Looking forward to providing you with the best possible service.