

AN3320K, AN3320S

VTR Playback Video Signal Processing Circuits

■ Outline

The AN3320K and the AN3320S are integrated circuits designed for VTR playback video signal processing circuits.

■ Features

- Built-in line noise canceler
- Built-in picture control circuit
- Supply voltage : $V_{cc}=5V$

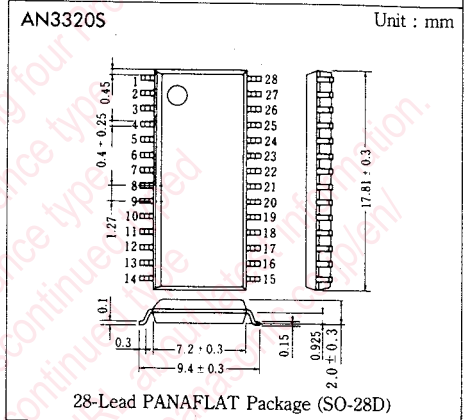
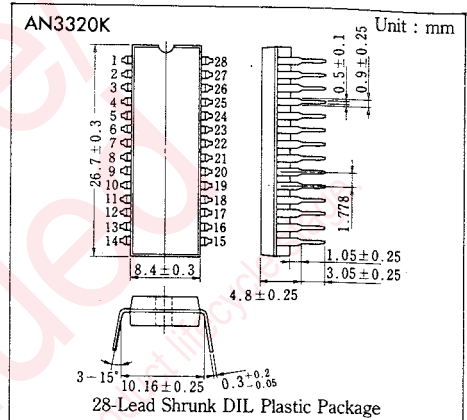

■ Block Diagram

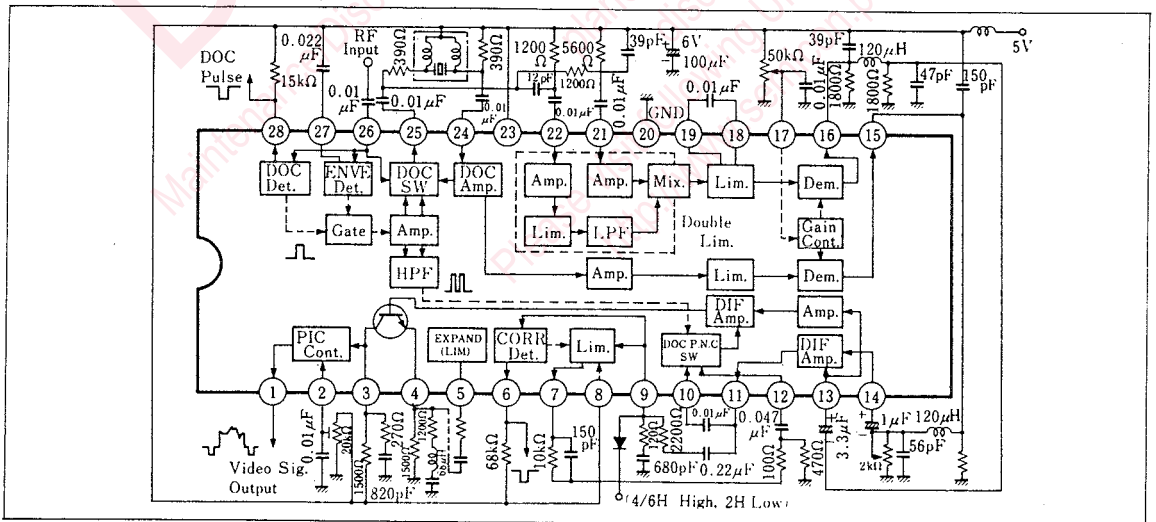

■ Absolute Maximum Ratings (Ta=25°C)

Item	Symbol	Rating	Unit
Supply Voltage	V _{CC}	6.0	V
Power Dissipation(Ta=70°C)	P _D	200	mW
Operating Ambient Temperature	T _{opr}	-20~+70	°C
Storage Temperature	T _{stg}	-55~+150	°C

■ Electrical Characteristics (V_{CC}=5V, Ta=25°C)

Item	Symbol	Test Circuit	Condition	min.	typ.	max.	Unit
Circuit Current	I ₂₃	1		17		30	mA
DOC Ampl. Gain	G ₂₅	2	Pin ⑭ Input (60mV _{P-P} , 4MHz)	13		16	dB
DOC Sensitivity ON	S ₂₈	3	Pin ⑮ Input (4MHz), 0 dB=350mV _{P-P}	-15		-11.5	dB
DOC Sensitivity OFF(Hysteresis)	ΔS ₂₈	3	Pin ⑮ Input (4MHz), 0 dB=350mV _{P-P}	-5		-0.5	dB
Sub FM Demodulation Det. Sensitivity	S ₁₅	4	Pin ⑭ Input (50mV _{P-P}) ⑰ 3.5V F ₁₁ is multiplied by Gain(0dB=250mV)	2.5			dB
Sub FM Demodulation Det. Limitation	L _{f15}	4	Pin ⑭ Input (100mV _{P-P}) Pin ⑰ 3.5V	7			MHz
Main FM Demodulation Det. Sensitivity	S ₁₆	5	Pin ⑰ Input (150mV _{P-P}) ⑰ 3.5V F ₁₁ is multiplied by Gain(0dB=250mV)	2.5			dB
Main FM Demodulation Det. Limitation	L _{f16}	5	Pin ⑰ Input (100mV _{P-P}) ⑰ 3.5V	7			MHz
Difference Det. Amp. Gain A	G ₁₁₋₁	6	Pin ⑬ Input (100mV _{P-P} , 1MHz)	13.5		16.5	dB
Difference Det. Amp. Gain B	G ₁₁₋₂	6	Pin ⑬ Input (100mV _{P-P} , 1MHz)	12		15	dB
Differential + MIX Amp. Gain	G ₄₋₁	7	Same as above	7		10	dB
MIX Amp. Ratio	G ₄₋₂	7	Pin ⑫ Input (500mV _{P-P} , 1MHz)	-5.5		-2.5	dB
Line Noise Canceler Switch Changeover Level Difference	Δv ₄	8	Pin ⑩ Control Pulse	-5		5	mV
Line Noise Canceler Switch Crosstalk	CT ₄	9	500mV _{P-P} , 1MHz ④ Output ratio of ⑩ and ⑫			-40	dB
Line Noise Canceler Limiter Gain	G ₇	10	Pin ⑨ Input (40mV _{P-P} , 1MHz)	15.5		19	dB
Line Noise Canceler Correlative Det. Sensitivity ON	S ₆	11	Pin ⑨ Input (4MHz), 0dB=60mV _{P-P}	1.5		4.5	dB
Line Noise Canceler Correlative Det. Sensitivity OFF(Hysteresis)	ΔS ₆	11	Pin ⑨ Input (4MHz), 0dB=60mV _{P-P}	-4		-0.1	dB
Picture Control Gain	G ₁	12	Pin ③ Input (250mV _{P-P} , 1MHz) Output ratio of Pin②0V and 2.5V	-1.5		0.5	dB
Picture Control Frequency Characteristics A	f ₁₋₁	12	Pin ③ Input (250mV _{P-P} , 1MHz)			-3	dB
Picture Control Frequency Characteristics B	f ₁₋₂	12	Pin ③ Input (250mV _{P-P} , 1MHz) Output ratio of Pin⑤5V and 2.5V	5			dB

Note : Operating Supply Voltage Range : V_{CC(oper)} = 4.5~5.5V

Test Circuit 1 (I₂₃)

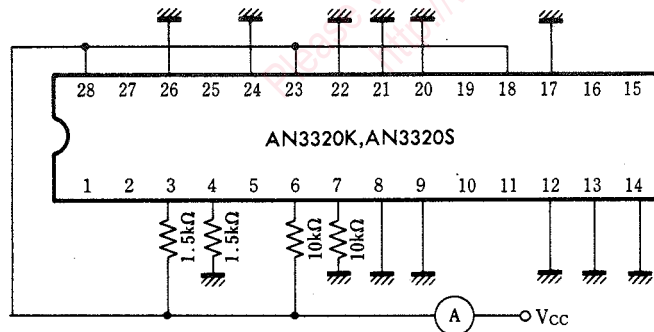

Test Circuit 2 (G_{25})

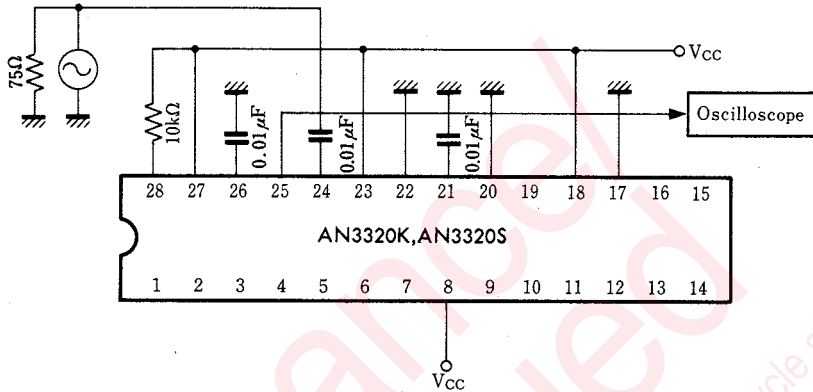

Test Circuit 3 (S_{28} , ΔS_{28})

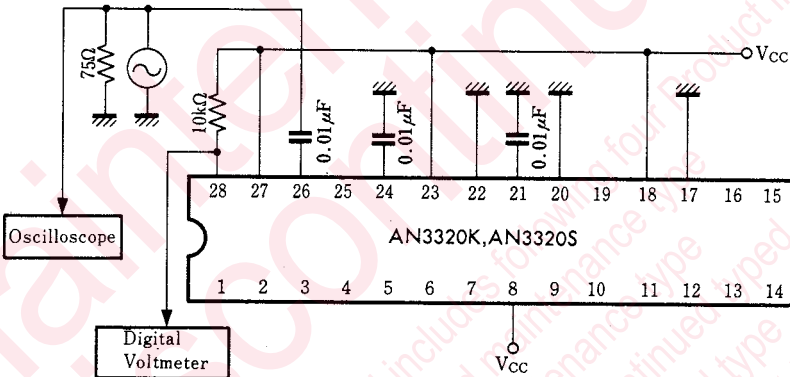

- S_{28-1} : Input level when Pin 28 output goes to Low
- S_{28-2} : Difference between input level and S_{28-1} when Pin 28 output goes to High

Test Circuit 4 (S_{15} , L_{15})

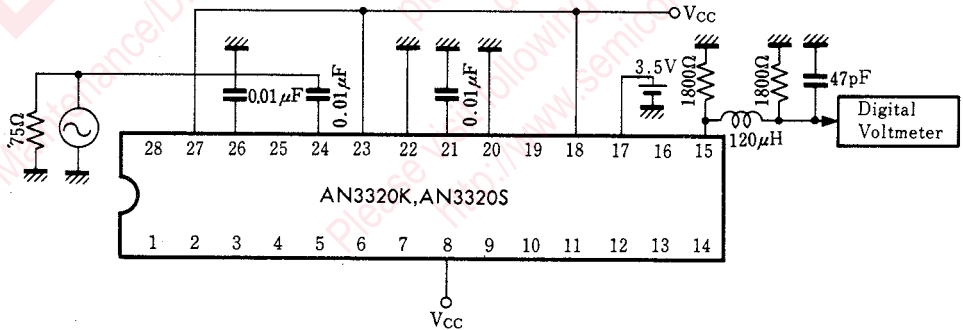

- S_{15} : Pin 15 output difference of input frequency 3.5MHz and 4.5MHz for Pin 24 is multiplied by F_{11} differential + Mix. Amp. gain.
- L_{15} : Pin 24 input frequency when Pin 15 output changes

Test Circuit 5 (S_{16} , L_{116})

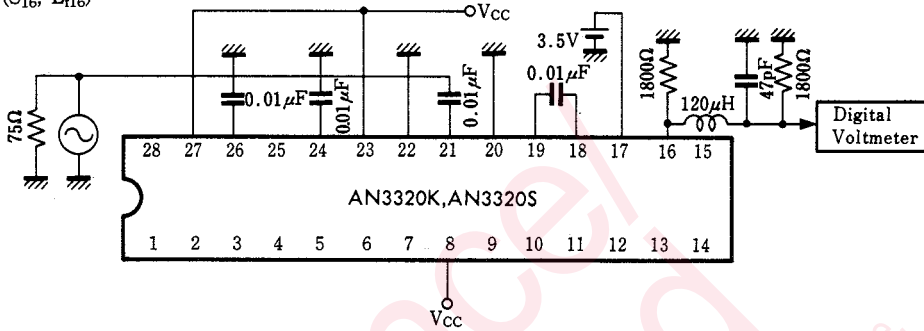

- S_{16} : Pin ⑮ output difference of input frequency 3.5MHz and 4.5MHz for Pin ⑳ is multiplied by F_{11} differential + Mix. Amp. gain.
- L_{116} : Pin ㉑ input frequency when Pin ⑮ output changes

Test Circuit 6 (G_{11-1} , G_{11-2})

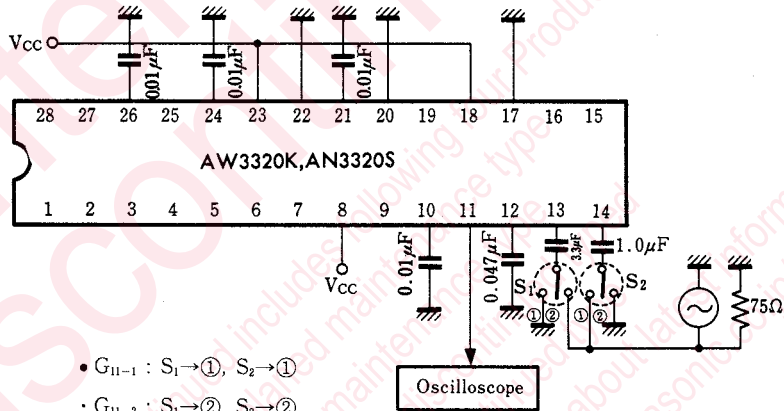

- G_{11-1} : $S_1 \rightarrow ①$, $S_2 \rightarrow ①$
- G_{11-2} : $S_1 \rightarrow ②$, $S_2 \rightarrow ②$

Test Circuit 7 (G_{4-1} , G_{4-2})

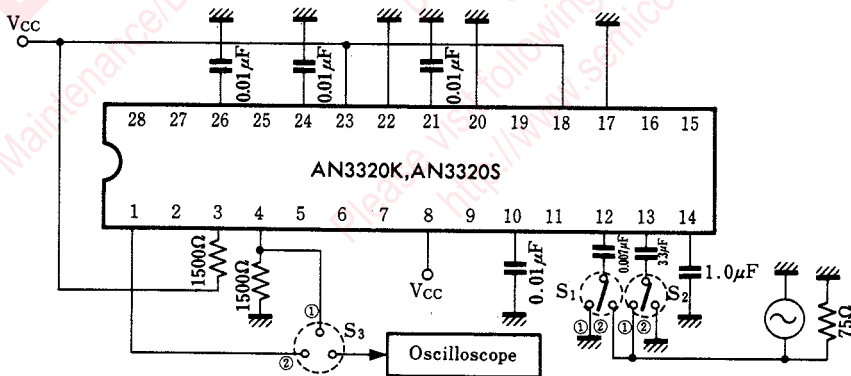

- G_{4-1} : $S_1 \rightarrow ①$, $S_2 \rightarrow ①$, $S_3 \rightarrow ②$
- G_{4-2} : $S_1 \rightarrow ②$, $S_2 \rightarrow ②$, $S_3 \rightarrow ①$

Test Circuit 8 (Δv_4)

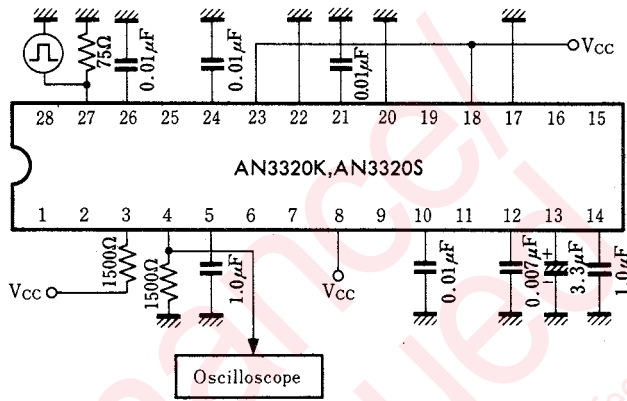

Test Circuit 9 (CT₄)

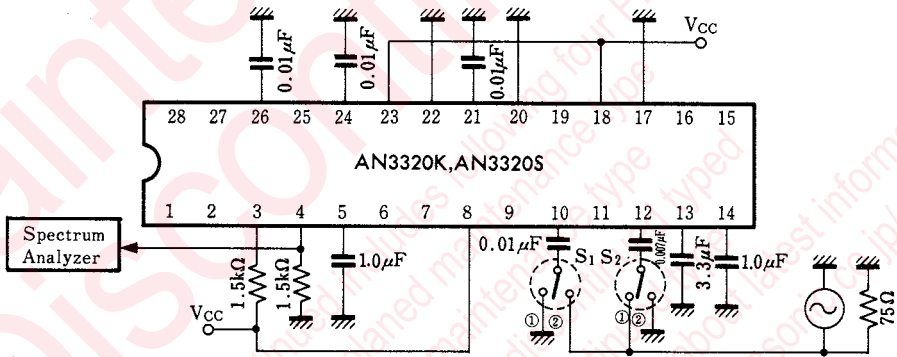

• CT₄: Pin ④ output for Pin ⑫ and element ratio for Pin ⑩ input corresponding to element

Test Circuit 10 (G₇)

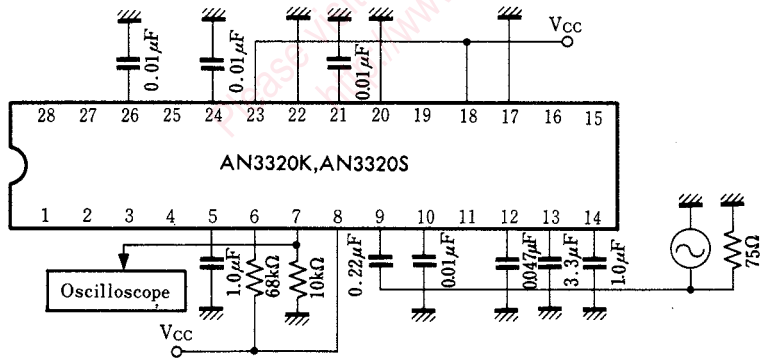

Test Circuit 11 (v_{6-1} , v_{6-2})

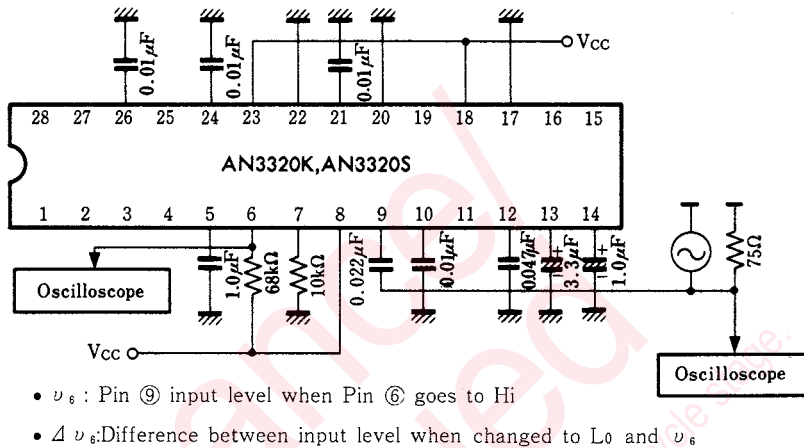

Test Circuit 12 (v_{6-2})

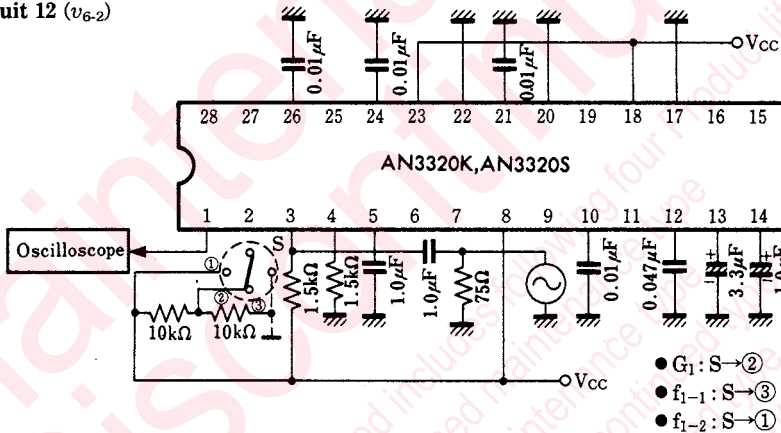

Application Circuit

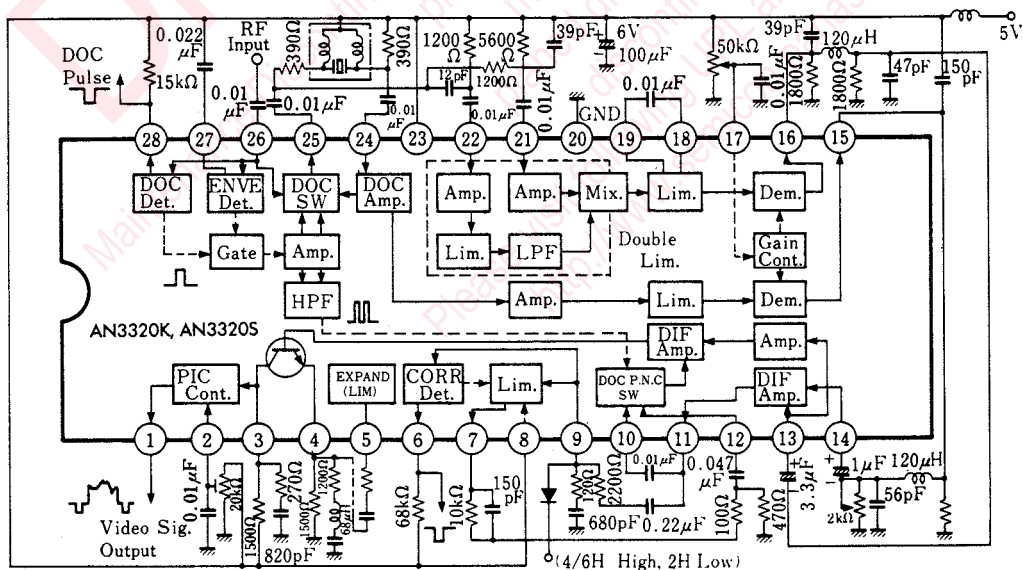

■ Pin

Pin No.	Pin Name	Pin No.	Pin Name
1	Video Output	15	DEM(1H DL)Output
2	Picture Control	16	DEM Output
3	De-emphasis	17	DEM Gain Control
4	Peaking	18	LIM
5	Extension	19	LIM
6	Relative Detecting Pulse Output	20	GND
7	Line N.C. LIM. Output	21	Double LIM LPF Input
8	To Except Rec V _{cc}	22	Double LIM HPF Input
9	Line N.C. LIM. Input	23	V _{cc}
10	Diff. Sig. Input	24	1H Delay RF Input
11	Diff. Sig. Output	25	RF Output
12	Limited Sig. Input	26	RF Input
13	Video Input	27	Envelop DET
14	Video(1H DL)Input	28	DOC Pulse Output

Notes for Use

- Pin ⑧ shall be always used in connection with Pin ⑭
- Power supply to be supplied to the variable resistor added to Pins ② and ⑰ shall be used the same as that supplied to this integrated circuit.
- Since deterioration or destory of characteristics due to flow of overcurrent caused by reverse current, careful attention should be taken to handling.

Request for your special attention and precautions in using the technical information and semiconductors described in this book

- (1) If any of the products or technical information described in this book is to be exported or provided to non-residents, the laws and regulations of the exporting country, especially, those with regard to security export control, must be observed.
- (2) The technical information described in this book is intended only to show the main characteristics and application circuit examples of the products. No license is granted in and to any intellectual property right or other right owned by Panasonic Corporation or any other company. Therefore, no responsibility is assumed by our company as to the infringement upon any such right owned by any other company which may arise as a result of the use of technical information described in this book.
- (3) The products described in this book are intended to be used for standard applications or general electronic equipment (such as office equipment, communications equipment, measuring instruments and household appliances).
Consult our sales staff in advance for information on the following applications:
 - Special applications (such as for airplanes, aerospace, automobiles, traffic control equipment, combustion equipment, life support systems and safety devices) in which exceptional quality and reliability are required, or if the failure or malfunction of the products may directly jeopardize life or harm the human body.
 - Any applications other than the standard applications intended.
- (4) The products and product specifications described in this book are subject to change without notice for modification and/or improvement. At the final stage of your design, purchasing, or use of the products, therefore, ask for the most up-to-date Product Standards in advance to make sure that the latest specifications satisfy your requirements.
- (5) When designing your equipment, comply with the range of absolute maximum rating and the guaranteed operating conditions (operating power supply voltage and operating environment etc.). Especially, please be careful not to exceed the range of absolute maximum rating on the transient state, such as power-on, power-off and mode-switching. Otherwise, we will not be liable for any defect which may arise later in your equipment.
 - Even when the products are used within the guaranteed values, take into the consideration of incidence of break down and failure mode, possible to occur to semiconductor products. Measures on the systems such as redundant design, arresting the spread of fire or preventing glitch are recommended in order to prevent physical injury, fire, social damages, for example, by using the products.
- (6) Comply with the instructions for use in order to prevent breakdown and characteristics change due to external factors (ESD, EOS, thermal stress and mechanical stress) at the time of handling, mounting or at customer's process. When using products for which damp-proof packing is required, satisfy the conditions, such as shelf life and the elapsed time since first opening the packages.
- (7) This book may be not reprinted or reproduced whether wholly or partially, without the prior written permission of our company.



LittleDiode supplies new, hard to find or obsolete electronic components and semiconductors all over the world.

With over two million different components listed you are sure to find the part you need.

Feel free to visit us today at our online store:

LittleDiode.com

Looking forward to providing you with the best possible service.