

**SILICON TRANSISTOR**  
**2SA1608**

**HIGH FREQUENCY AMPLIFIER AND SWITCHING**  
**PNP SILICON EPITAXIAL TRANSISTOR**

**PACKAGE DIMENSIONS**

in millimeters

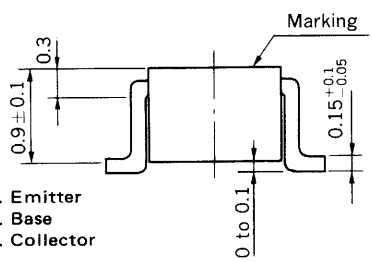
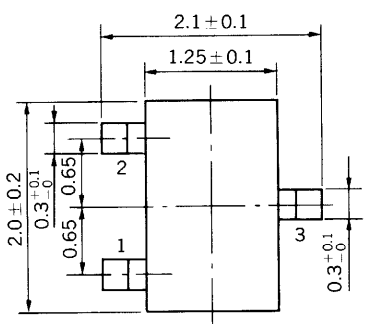

- 1. Emitter
- 2. Base
- 3. Collector

**FEATURES**

- High  $f_T$  :  $f_T = 400$  MHz
- Complementary to 2SC3739

**ABSOLUTE MAXIMUM RATINGS**

Maximum Voltages and Current ( $T_a = 25^\circ\text{C}$ )

Collector to Base Voltage	$V_{CB0}$	-60	V
Collector to Emitter Voltage	$V_{CEO}$	-40	V
Emitter to Base Voltage	$V_{EBO}$	-5.0	V
Collector Current (DC)	$I_C$	-500	mA

Maximum Power Dissipation

Total power Dissipation at $25^\circ\text{C}$ Ambient Temperature	$P_T$	150	mW
---	-------	-----	----

Maximum Temperatures

Junction Temperature	$T_j$	150	$^\circ\text{C}$
Storage Temperature Range	$T_{stg}$	-55 to +150	$^\circ\text{C}$

**ELECTRICAL CHARACTERISTICS ( $T_a = 25^\circ\text{C}$ )**

CHARACTERISTIC	SYMBOL	MIN.	TYP.	MAX.	UNIT	TEST CONDITIONS
Collector Cutoff Current	$I_{CBO}$			-100	nA	$V_{CB} = -40\text{ V}, I_E = 0$
Emitter Cutoff Current	$I_{EBO}$			-100	nA	$V_{EB} = -4.0\text{ V}, I_C = 0$
DC Current Gain	$h_{FE1}^*$	75	140	300		$V_{CE} = -2.0\text{ V}, I_C = -150\text{ mA}$
DC Current Gain	$h_{FE2}^*$	20	50			$V_{CE} = -2.0\text{ V}, I_C = -150\text{ mA}$
Collector Saturation Voltage	$V_{CE(sat)}^*$		-0.45	-0.75	V	$I_C = -500\text{ mA}, I_B = -50\text{ mA}$
Base Saturation Voltage	$V_{BE(sat)}^*$		-1.0	-1.30	V	$I_C = -500\text{ mA}, I_B = -50\text{ mA}$
Gain Bandwidth Product	$f_T$	150	400		MHz	$V_{CE} = -10\text{ V}, I_E = 20\text{ mA}$
Output Capacitance	$C_{ob}$		5.0	8.0	pF	$V_{CB} = -10\text{ V}, I_E = 0, f = 1.0\text{ MHz}$
Turn-on Time	$t_{on}$		25		ns	$V_{CC} = -30\text{ V}$
Storage Time	$t_{stg}$		70		ns	$I_C = 150\text{ mA}$
Turn-off Time	$t_{off}$		100		ns	$I_{B1} = -I_{B2} = 15\text{ mA}$

\* Pulsed:  $PW \leq 350\ \mu\text{s}$ , Duty Cycle  $\leq 2\%$

**$h_{FE}$  Classification**

Making	Y12	Y13	Y14
$h_{FE1}$	75 to 150	100 to 200	150 to 300

NEC cannot assume any responsibility for any circuits shown or represent that they are free from patent infringement.

SWITCHING TIME TEST CIRCUIT

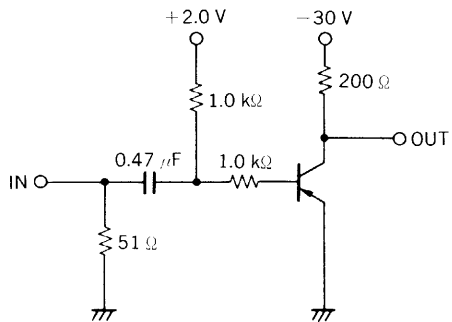

$t_{on}$  SWITCHING

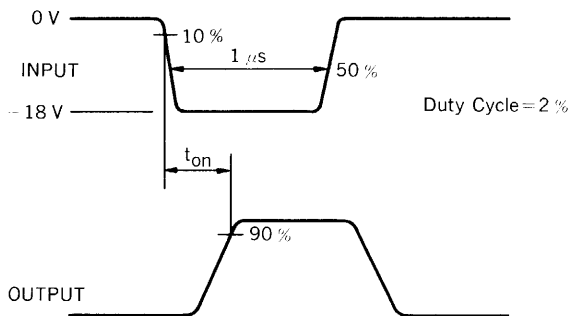

VOLTAGE WAVEFORMS

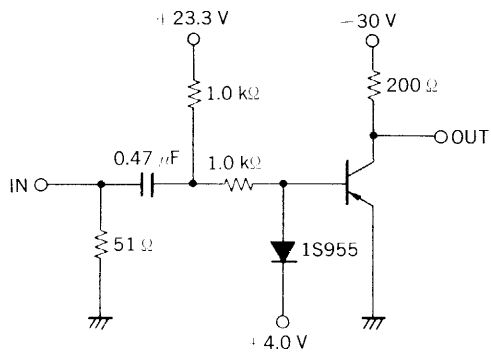

$t_{stg}$ ,  $t_{off}$  SWITCHING

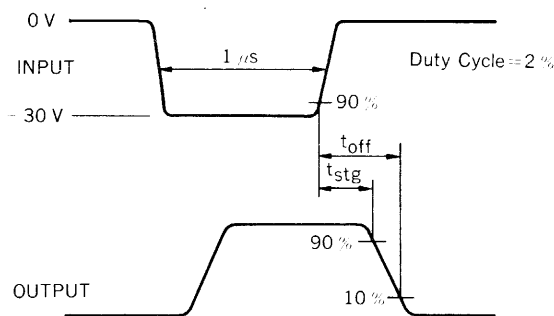

VOLTAGE WAVEFORMS

TYPICAL CHARACTERISTICS ( $T_a = 25^\circ\text{C}$ )

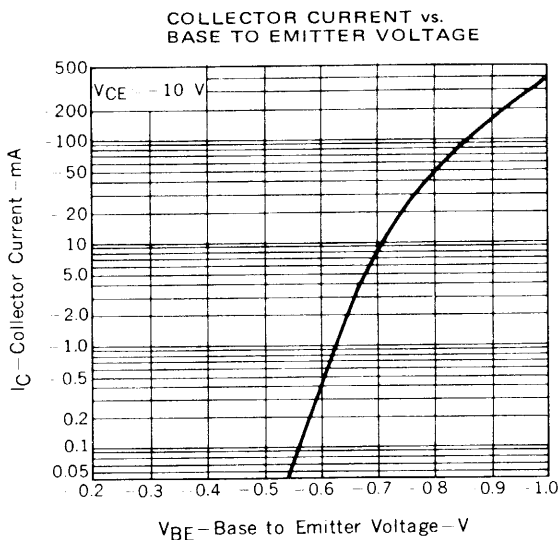
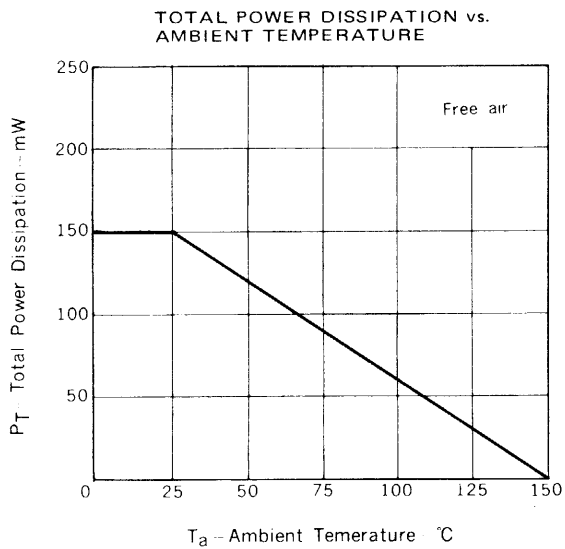

COLLECTOR CURRENT vs. COLLECTOR TO EMITTER VOLTAGE

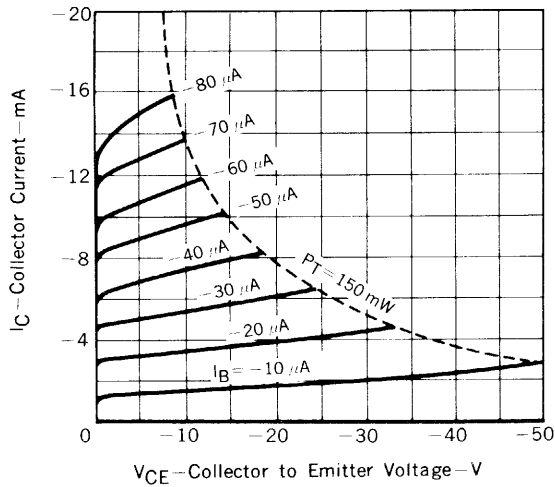

BASE AND COLLECTOR SATURATION VOLTAGE vs. COLLECTOR CURRENT

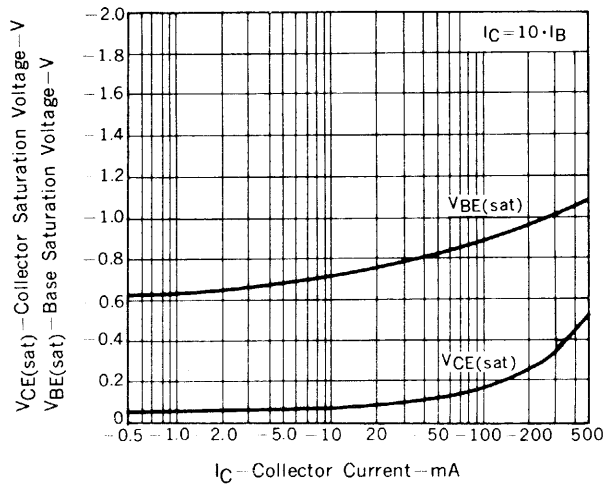

DC CURRENT GAIN vs. COLLECTOR CURRENT

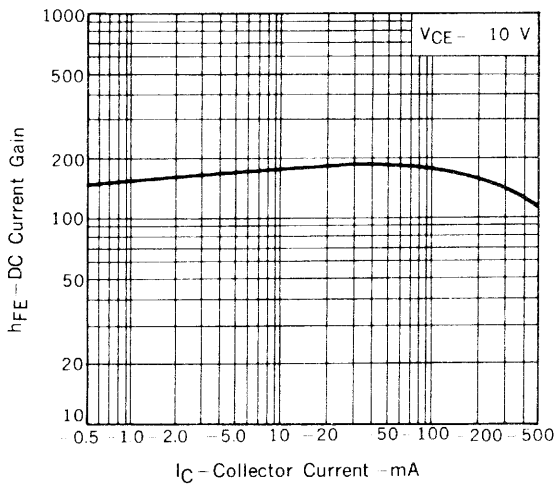

GAIN BANDWIDTH PRODUCT vs. EMITTER CURRENT

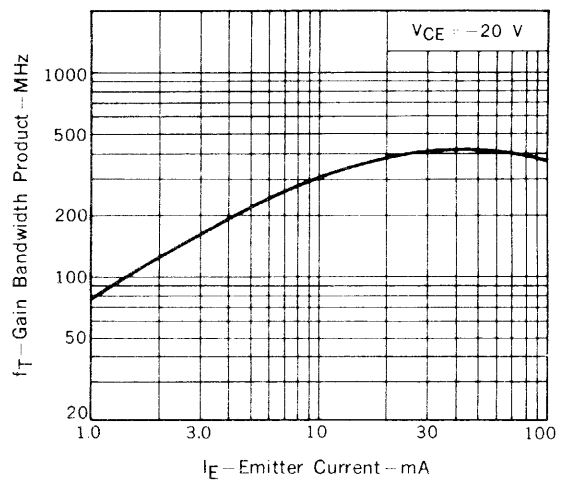

INPUT AND OUTPUT CAPACITANCE vs. REVERSE VOLTAGE

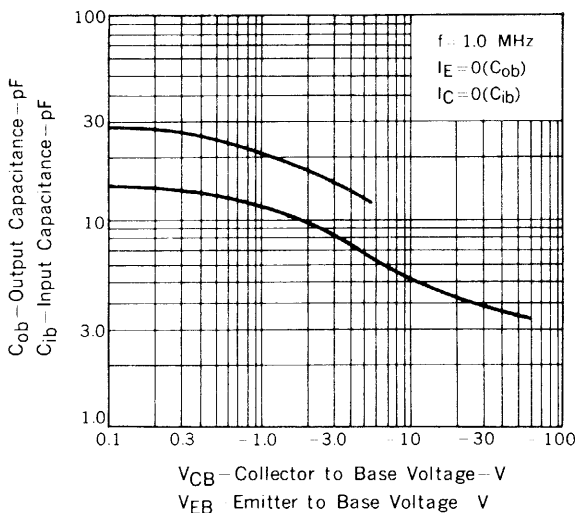

DELAY TIME vs. COLLECTOR CURRENT

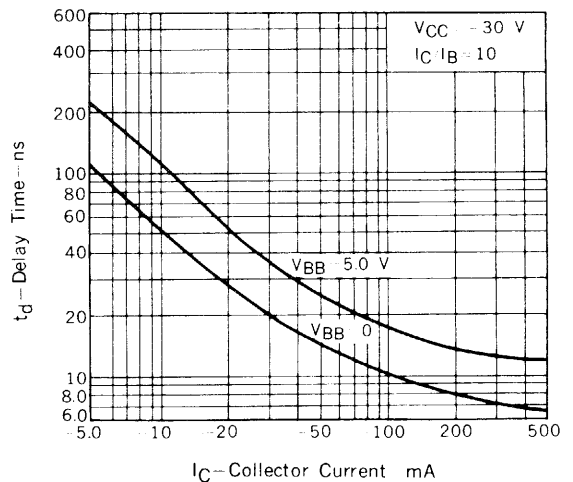

RISE TIME vs. COLLECTOR CURRENT

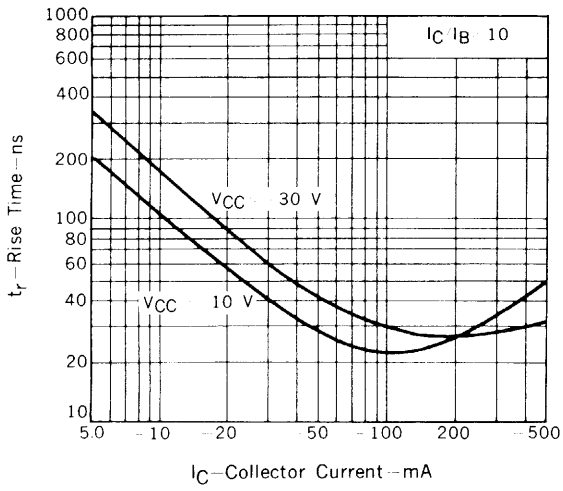

STORAGE TIME vs. COLLECTOR CURRENT

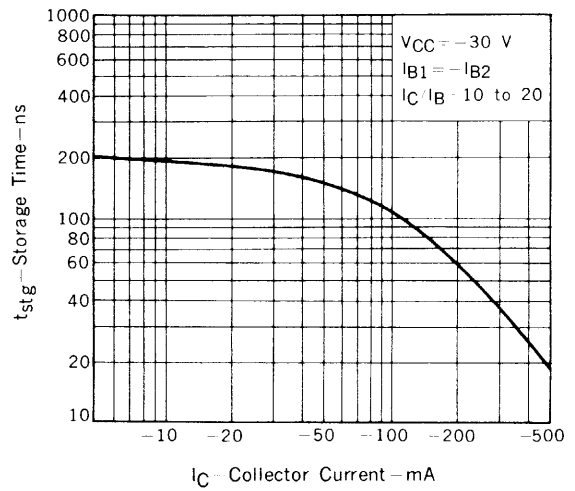

FALL TIME vs. COLLECTOR CURRENT

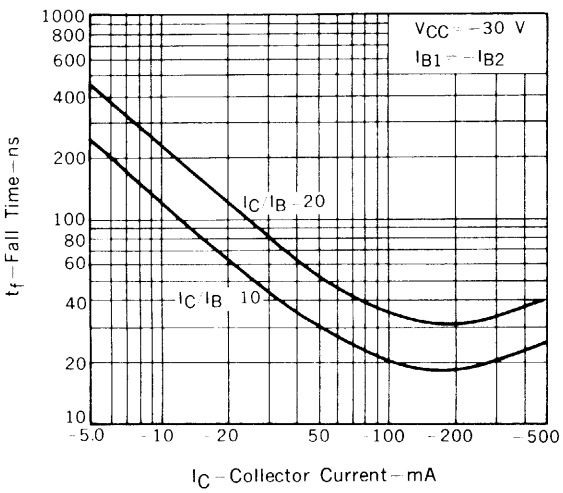



LittleDiode supplies new, hard to find or obsolete electronic components and semiconductors all over the world.

With over two million different components listed you are sure to find the part you need.

Feel free to visit us today at our online store:

[LittleDiode.com](http://LittleDiode.com)

Looking forward to providing you with the best possible service.