

# AN1358 (AN6562), AN1358S (AN6562S)

## Dual Operational Amplifiers

### ■ Overview

The AN1358 (AN6562) and AN1358S (AN6562S) are dual operational amplifiers with two phase compensation circuits built-in, have a wide range of operating supply voltage, and can operate on a single power supply.

They have electrical characteristics equivalent to those of the conventional operational amplifiers, and are low-powered and suitable for application to various circuits. Note) The type numbers in ( ) are old ones.

### ■ Features

- Built-in phase compensation circuits
- Wide range of input voltage: 0V to  $V_{CC}-1.5V$
- Wide range of operating supply voltage:  
Single power supply: 3 to 30V  
Dual power supply:  $\pm 1.5$  to  $\pm 15V$

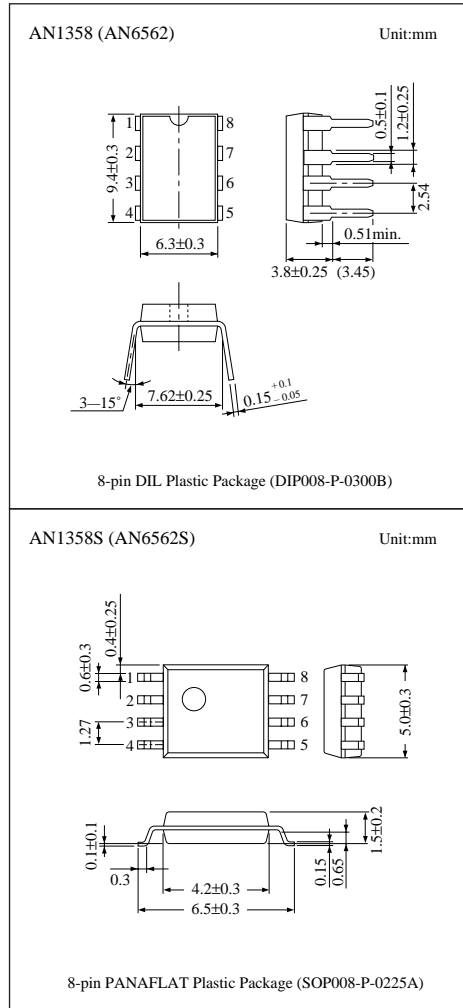

### ■ Block Diagram

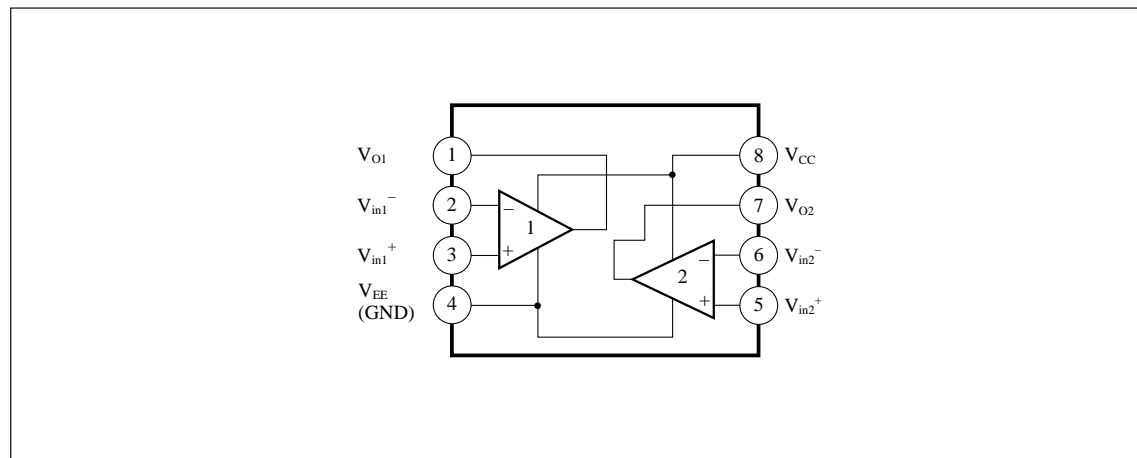

## ■ Absolute Maximum Ratings (Ta=25°C)

Parameter	Symbol	Rating	Unit
Supply voltage	V <sub>CC</sub>	32	V
Differential input voltage	V <sub>ID</sub>	32	V
Common-mode input voltage	V <sub>ICM</sub>	-0.3 to +32	V
Output voltage	V <sub>O</sub>	24	V
Power dissipation	AN1358 (AN6562)	P <sub>D</sub>	mW
	AN1358 (AN6562S)		
			360
Operating ambient temperature	T <sub>opr</sub>	-20 to +75	°C
Storage temperature	AN1358 (AN6562)	T <sub>stg</sub>	°C
	AN1358S (AN6562S)		
			-55 to +125

## ■ Recommended Operating Range (Ta=25°C)

Parameter	Symbol	Range
Operating supply voltage range	V <sub>CC</sub>	Single power supply 3V to 30V
		Dual power supply ±1.5V to ±15V

## ■ Electrical Characteristics (V<sub>CC</sub>=5V, Ta=25°C)

Parameter	Symbol	Condition	min	typ	max	Unit
Input offset voltage	V <sub>I (offset)</sub>	R <sub>S</sub> =50Ω	—	2	7	mV
Input bias current	I <sub>bias</sub>		—	—	250	nA
Input offset current	I <sub>IO</sub>		—	—	50	nA
Common-mode input voltage width	V <sub>CM</sub>		0	—	V <sub>CC</sub> -1.5	V
Supply current	I <sub>CC</sub>	R <sub>L</sub> =∞	—	0.6	1.2	mA
Voltage gain	G <sub>V</sub>	R <sub>L</sub> ≥2kΩ	—	100	—	dB
Maximum output voltage	V <sub>O (max.)</sub>	R <sub>L</sub> ≥2kΩ	V <sub>CC</sub> -1.5	—	—	V
Common-mode rejection ratio	CMR		65	85	—	dB
Supply voltage rejection ratio	SVR		65	100	—	dB
Channel separation	CS	f=1 to 20kHz	—	120	—	dB
Output source current	I <sub>O (source)</sub>	V <sub>in</sub> <sup>+</sup> =1V, V <sub>in</sub> <sup>-</sup> =0V	20	40	—	mA
Output sink current	I <sub>SINK</sub>	V <sub>in</sub> <sup>+</sup> =0V, V <sub>in</sub> <sup>-</sup> =1V	10	20	—	mA

## ■ Application Circuit

Non-inverting Amplifier

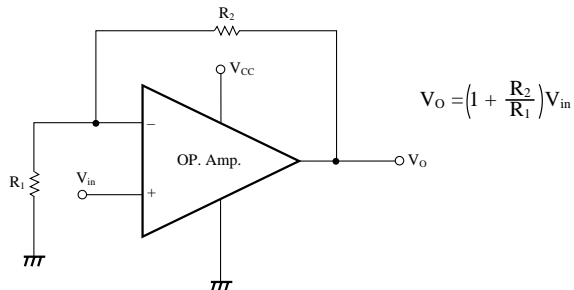

## ■ Pin Descriptions

Pin No.	Pin name
1	Ch.1 output pin
2	Ch.1 inverting input pin
3	Ch.1 non-inverting input pin
4	Negative supply voltage (GND)
5	Ch.2 non-inverting input pin
6	Ch.2 inverting input pin
7	Ch.2 output pin
8	Positive supply voltage

## ■ Characteristics Curve

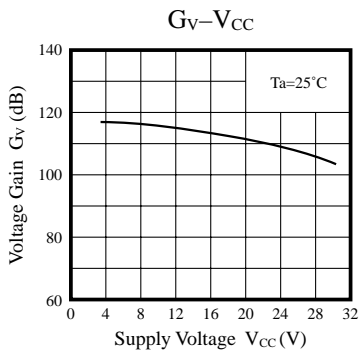
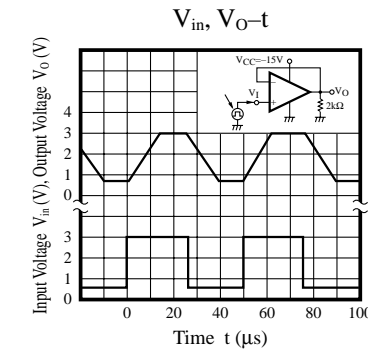
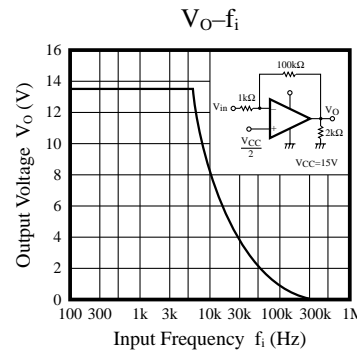
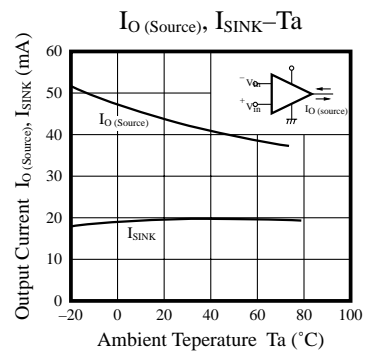
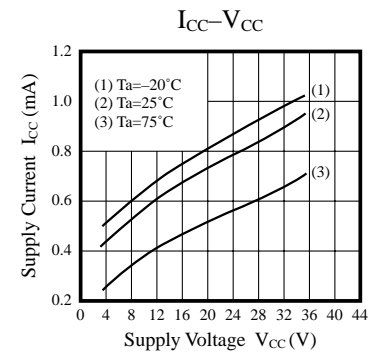
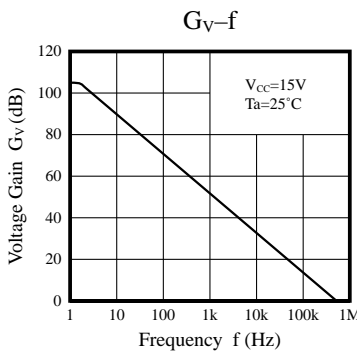
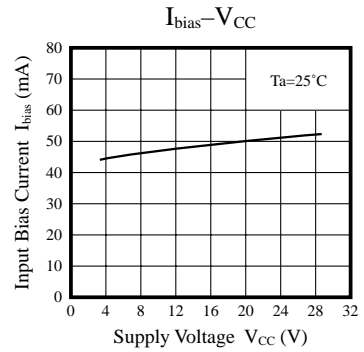
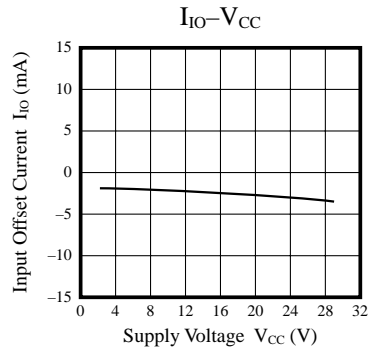
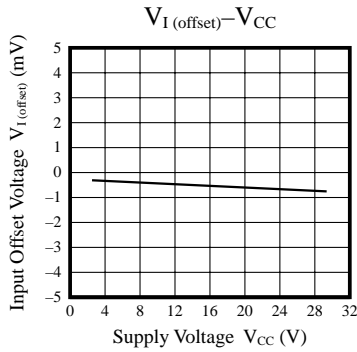



LittleDiode supplies new, hard to find or obsolete electronic components and semiconductors all over the world.

With over two million different components listed you are sure to find the part you need.

Feel free to visit us today at our online store:

[LittleDiode.com](http://LittleDiode.com)

Looking forward to providing you with the best possible service.