

AN6888, AN6889

Dual 5-Dot LED Driver Circuits

Outline

The AN6888 and the AN6889 are integrated circuits designed for driving 5-dot \times 2-channel LED and enable a logarithmic (dB) bar graph display in response to the input signal.

The built-in high gain rectifier Amp. is widely applicable for VU meter, signal meter, etc.

Because the output is the constant-current drawing system, the constant-current value can be varied with the external resistor.

10-dot \times 2-channel LED can be driven by combining the AN6888 and the AN6889.

Features

- Wide range of operating voltage : $V_{CC(oper.)} = 5 \sim 16V$
- Power consumption can be reduced due to series connection of LEDs
- Wide range of fixed currents : $5 \sim 25mA$
- Built-in high gain Amp. : $G_v = 26dB$ (typ.)

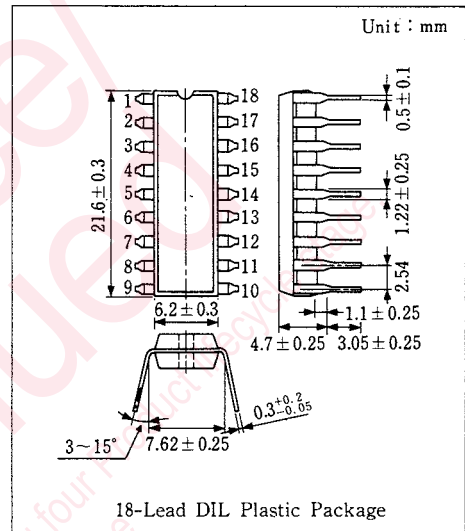

Block Diagram

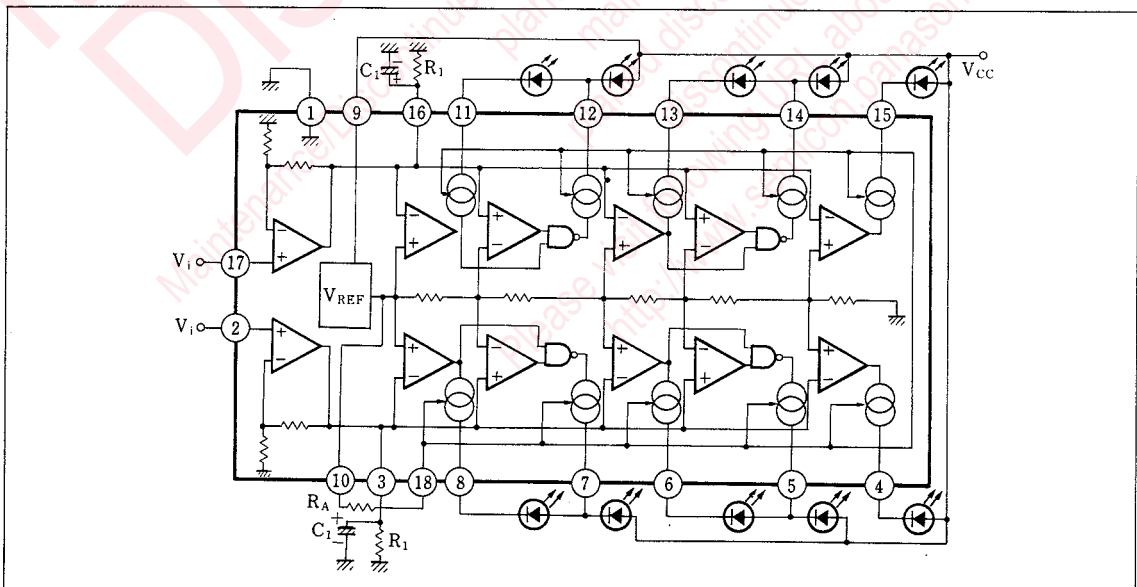

■ Pin

Pin No.	Pin Name	Pin No.	Pin Name
1	GND	10	Ref. Voltage
2	Amp. 1 Input	11	LED 6 Output
3	Amp. 1 Output	12	LED 7 Output
4	LED 1 Output	13	LED 8 Output
5	LED 2 Output	14	LED 9 Output
6	LED 3 Output	15	LED 10 Output
7	LED 4 Output	16	Amp. 2 Output
8	LED 5 Output	17	Amp. 2 Input
9	V _{CC}	18	LED Current Set Input

■ Absolute Maximum Ratings (Ta=25°C)

Item		Symbol	Rating	Unit
Voltage	Supply Voltage	V _{CC}	18	V
	Operational Amp. Input Voltage	V _{2,17-1}	-0.5 V _{CC}	V
	LED Output Pin Voltage	V _{4-8,11-15-1}	V _{CC}	V
	Reference Pin Input Voltage	V ₁₀₋₁	6	V
	Circuit Voltage	V _{3,16-1}	6	V
Current	Supply Current	I _{CC}	15	mA
	LED Output Pin Current	I _{4-8,11-15}	30	mA
	Reference Voltage Output Current	I ₁₀	-5	mA
	R _A Pin Input Current	I ₁₈	10	mA
Power Dissipation (Ta ≤ 75°C)		P _D	540	mW
Temperature	Operating Ambient Temperature	T _{opr}	-30 ~ +75	°C
	Storage Temperature	T _{stg}	-55 ~ +150	°C

P_D - T_a

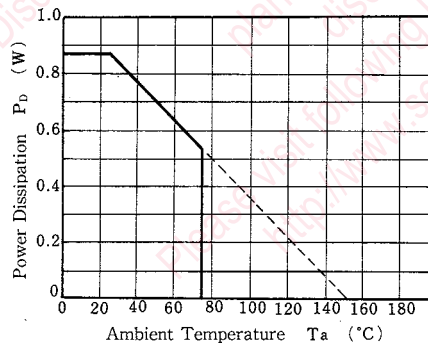

■ Electrical Characteristics (Ta=25°C, V_{CC}=9V)

Item	Symbol	Test Circuit	Condition	min.	typ.	max.	Unit
Current Consumption	I _{tot}	1	V ₂₋₁ =0V, R _A =open		5	9	mA
Input Bias Current	I _{Bias2}	2		-1		0	μA
	I _{Bias17}	2		-1		0	μA
	I _{Bias3}	3	V ₂₋₁ = -0.1V	-3		0	μA
	I _{Bias6}	3	V ₁₇₋₁ = -0.1V	-3		0	μA
Reference Voltage	V _{REF}	4		2.5	2.7	2.9	V
Output Sink Current	I _{SINK1-8,11-15}	5	R _A = open	4		9	mA
	I _{SINK3-8,11-15}	6	R _A = 5.6kΩ	11		21	mA
Amp. Gain	G _{V1}	7	V ₂₋₁ = 0.1V	24	26	28	dB
	G _{V2}	7	V ₁₇₋₁ = 0.1V	24	26	28	dB
Comparator Level (AN6888)	GD ₁	8	Pin④,⑮	-11	-10	-9	dB
	GD ₂	8	Pin⑤,⑭	-6	-5	-4	dB
	GD ₃	8	Pin⑥,⑬	-0.5	0	0.5	dB
	GD ₄	8	Pin⑦,⑫	2.5	3	3.5	dB
	GD ₅	8	Pin⑧,⑩	5	6	7	dB
Comparator Level (AN6889)	GD ₁	8	Pin④,⑮	-5	-4	-3	dB
	GD ₂	8	Pin⑤,⑭	-2.5	-2	-1.5	dB
	GD ₃	8	Pin⑥,⑬	-0.5	0	0.5	dB
	GD ₄	8	Pin⑦,⑫	1.5	2	2.5	dB
	GD ₅	8	Pin⑧,⑩	3	4	5	dB

Note) Operating Supply Voltage Range : V_{CC(OPP)} = 5 ~ 16V_O * AN6888 : V₃₋₁, V₁₆₋₁ = 1.4V is assumed to be 0dB. * AN6889 : V₃₋₁, V₁₆₋₁ = 1.76V is assumed to be 0dB.

Test Circuit 1 (I_{tot})

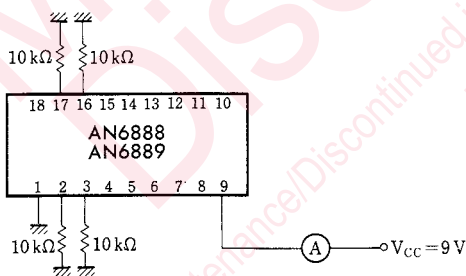

Test Circuit 2 (I_{Bias2}, I_{Bias17})

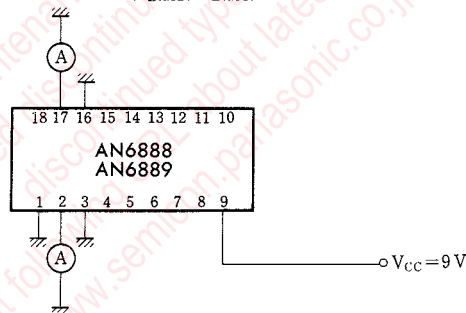

Test Circuit 3 (I_{Bias3}, I_{Bias6})

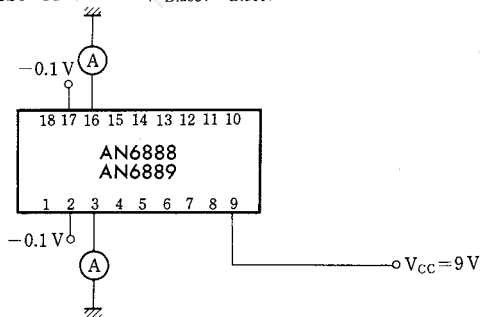

Test Circuit 4 (V_{REF})

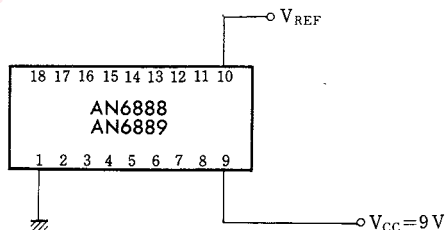

Test Circuit 5 ($I_{(SINK)4-8,11-15}$)

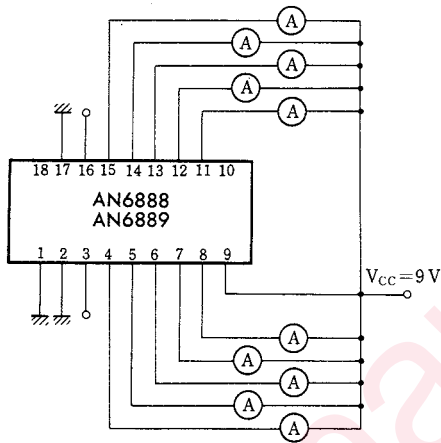

Test Circuit 6 ($I_{(SINK)4-8,11-15}$)

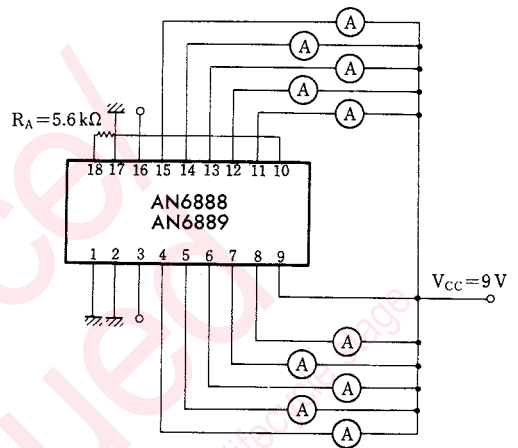

Test Circuit 7 (G_{V1}, G_{V2})

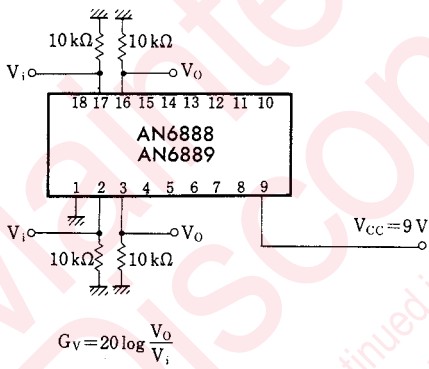

Test Circuit 8 ($GD_1, GD_2, GD_3, GD_4, GD_5$)

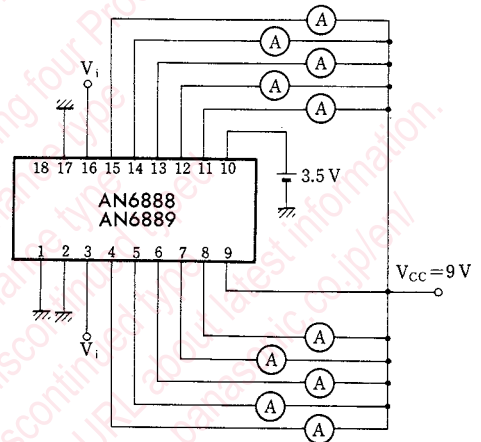

$V_{REF} - V_{CC}$

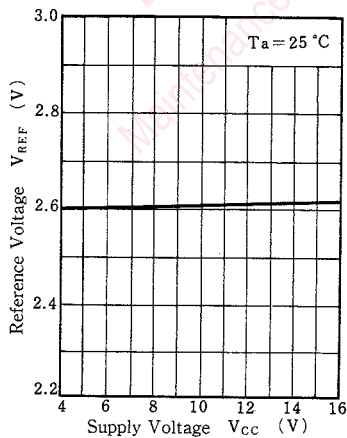

$V_{REF} - T_a$

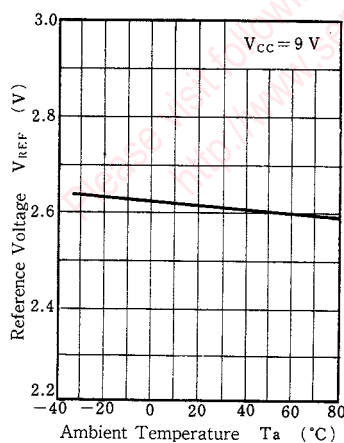

$I_{LED} - V_{CC}$

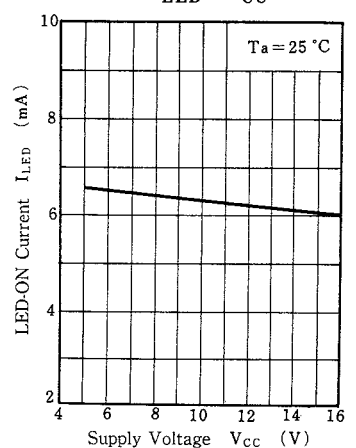

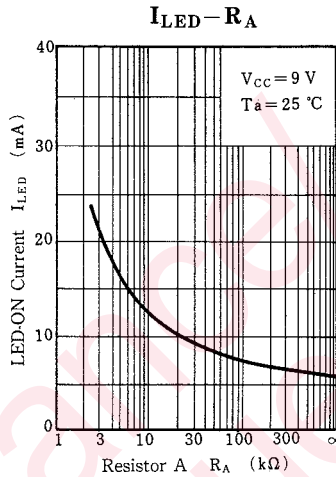
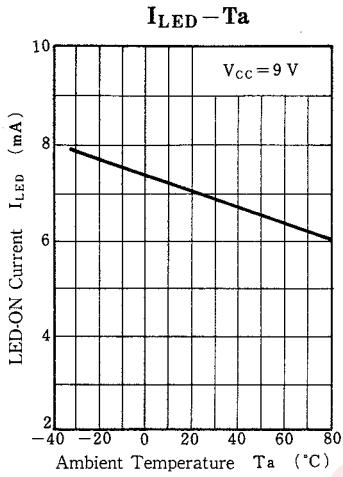

■ Application Circuit

● In case of 10-dot×2 (AN6888 and AN6889) application

LED	1	2	3	4	5	6	7	8	9	10
Level Value	-20	-15	-10	-7	-4	-2	0	2	4	6

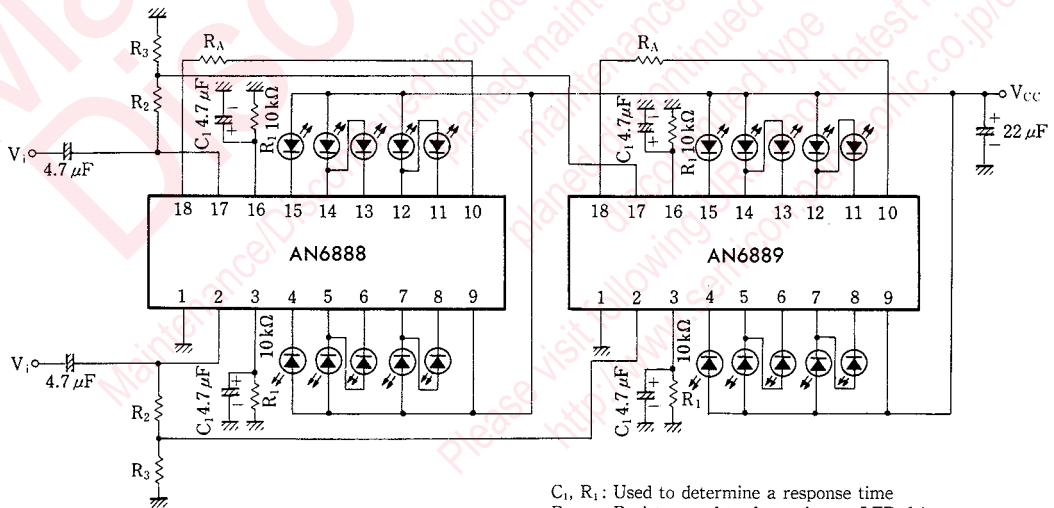

C_1, R_1 : Used to determine a response time
 R_A : Resistor used to determine an LED drive current
 R_2, R_3 : Resistors used to determine an LED level

Request for your special attention and precautions in using the technical information and semiconductors described in this book

- (1) If any of the products or technical information described in this book is to be exported or provided to non-residents, the laws and regulations of the exporting country, especially, those with regard to security export control, must be observed.
- (2) The technical information described in this book is intended only to show the main characteristics and application circuit examples of the products. No license is granted in and to any intellectual property right or other right owned by Panasonic Corporation or any other company. Therefore, no responsibility is assumed by our company as to the infringement upon any such right owned by any other company which may arise as a result of the use of technical information described in this book.
- (3) The products described in this book are intended to be used for standard applications or general electronic equipment (such as office equipment, communications equipment, measuring instruments and household appliances).
Consult our sales staff in advance for information on the following applications:
 - Special applications (such as for airplanes, aerospace, automobiles, traffic control equipment, combustion equipment, life support systems and safety devices) in which exceptional quality and reliability are required, or if the failure or malfunction of the products may directly jeopardize life or harm the human body.
 - Any applications other than the standard applications intended.
- (4) The products and product specifications described in this book are subject to change without notice for modification and/or improvement. At the final stage of your design, purchasing, or use of the products, therefore, ask for the most up-to-date Product Standards in advance to make sure that the latest specifications satisfy your requirements.
- (5) When designing your equipment, comply with the range of absolute maximum rating and the guaranteed operating conditions (operating power supply voltage and operating environment etc.). Especially, please be careful not to exceed the range of absolute maximum rating on the transient state, such as power-on, power-off and mode-switching. Otherwise, we will not be liable for any defect which may arise later in your equipment.
 - Even when the products are used within the guaranteed values, take into the consideration of incidence of break down and failure mode, possible to occur to semiconductor products. Measures on the systems such as redundant design, arresting the spread of fire or preventing glitch are recommended in order to prevent physical injury, fire, social damages, for example, by using the products.
- (6) Comply with the instructions for use in order to prevent breakdown and characteristics change due to external factors (ESD, EOS, thermal stress and mechanical stress) at the time of handling, mounting or at customer's process. When using products for which damp-proof packing is required, satisfy the conditions, such as shelf life and the elapsed time since first opening the packages.
- (7) This book may be not reprinted or reproduced whether wholly or partially, without the prior written permission of our company.



LittleDiode supplies new, hard to find or obsolete electronic components and semiconductors all over the world.

With over two million different components listed you are sure to find the part you need.

Feel free to visit us today at our online store:

LittleDiode.com

Looking forward to providing you with the best possible service.