

# AN7130

## 4.2W Audio Power Amplifier

### ■ Description

The AN7130 is a monolithic integrated circuit designed for audio high power amplifiers in consumer applications. It is also suitable for portable radios and cassette recorders.

### ■ Features

- High maximum output power:  $P_O = 4.2W$  at  $V_{CC} = 13.2V$ ,  $R_L = 4\Omega$
- Low quiescent current:  $I_{CQ} = 20mA$  at  $V_{CC} = 13.2V$

### ■ Pin

Pin No.	Pin Name
1	Output
2	GND
3	Phase Compensation
4	N.F.B.
5	Input
6	Ripple Filter
7	Ripple Filter
8	Bootstrap
9	$V_{CC}$

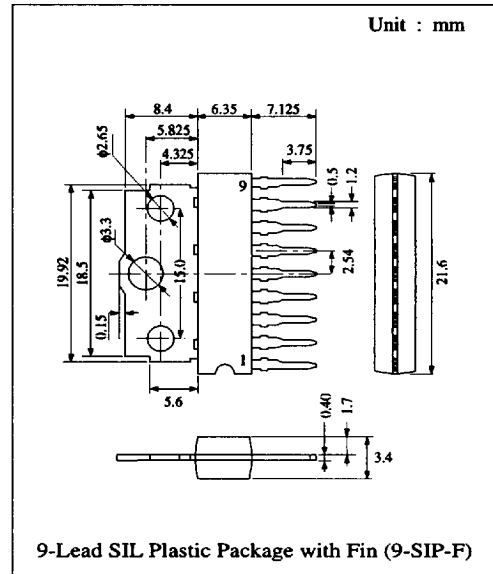

### ■ Block Diagram

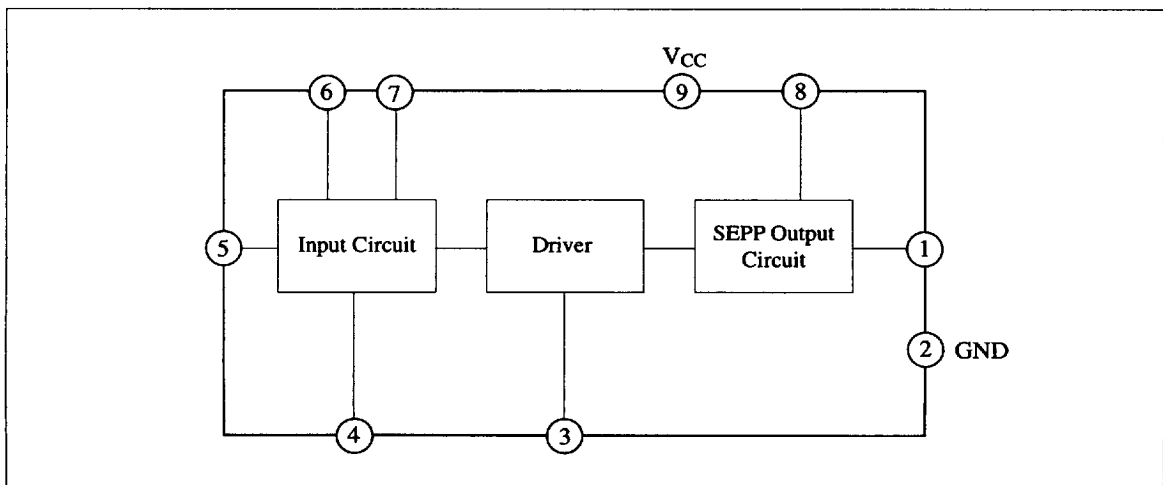

■ 6932852 0013776 704 ■

Panasonic

■ Absolute Maximum Ratings (Ta=25°C)

Item	Symbol	Rating	Unit
Supply Voltage	V <sub>CC</sub>	18	V
Supply Current	I <sub>CC</sub>	3	A
Power Dissipation	P <sub>D</sub>	10	W
Operating Ambient Temperature	Topr	-30 ~ +75	°C
Storage Temperature	Tstg	-40 ~ +150	°C

Operating Supply Voltage Range: V<sub>CC</sub> = 4.0V ~ 18.0V

■ Electrical Characteristics (V<sub>CC</sub>=13.2V, R<sub>L</sub>=4Ω, f=1kHz, Ta=25±2°C)

Item	Symbol	Condition	min.	typ.	max.	Unit
Quiescent Current	I <sub>CQ</sub>	V <sub>in</sub> = 0mV	10	20	50	mA
Voltage Gain	G <sub>V</sub>	V <sub>in</sub> = 5mV	43	46	49	dB
Output Power	P <sub>O</sub>	THD = 10%	3.7	4.2		W
Total Harmonic Distortion	THD	V <sub>in</sub> = 5mV		0.4	1.5	%
Output Noise Voltage	V <sub>no</sub>	R <sub>g</sub> = 10kΩ		0.5	1.2	mV
Input Impedance	Z <sub>in</sub>			25		kΩ

■ Application Circuit

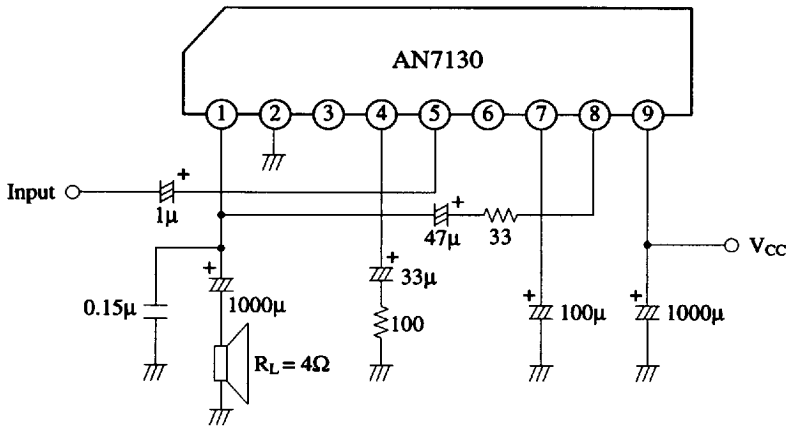

## ■ Characteristics Curve

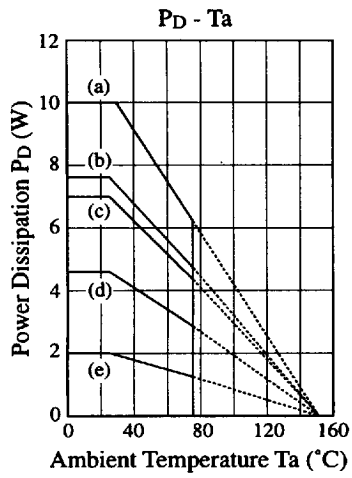

- (a) Infinite heat sink
- (b)  $100\text{cm}^2 \times 3\text{mm Al}$  (black colour coated) or a  $200\text{cm}^2 \times 2\text{mm Al}$  (not lacquered) heat sink.
- (c)  $100\text{cm}^2 \times 2\text{mm Al}$  (not lacquered) heat sink
- (d)  $25\text{cm}^2 \times 2\text{mm Al}$  (not lacquered) heat sink
- (e) Without heat sink