

AN8377N

3-channel Linear Driver

■ Overview

The AN8377N is an IC which incorporates 3 circuits of BTL drivers for driving various DC motors such as actuators (focus, tracking, traverse), spindles, and loading of the CD players, and the +5V low drop type power supply.

■ Features

- Operating supply voltage range ; $V_{CC}=5.5V$ to $18V$
- Built-in 3 circuits of voltage BTL drivers
(maximum drive current : $500mA$)
- Stable circuit operation against supply voltage change and temperature change due to the built-in stabilized power supply
- Built-in +5V low drop power supply (external PNP power transistor)
- Built-in reset circuit (reset voltage : $4.82V$)
- Built-in thermal protective circuit (operating temperature : 159 ; typ.)
- Built-in power cut circuit (motor driver 1 only)

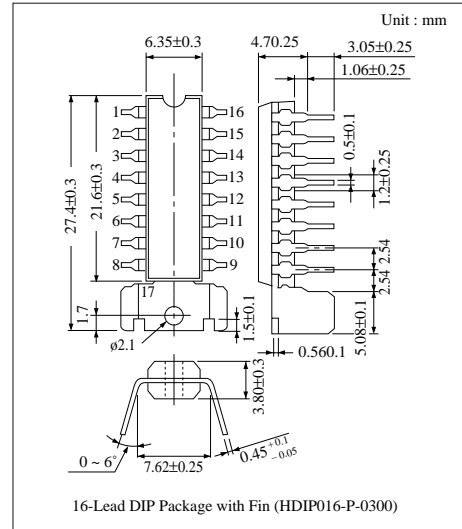

■ Applications

Linear driving of the DC motors and actuators of the CD players, CD radio cassette tape recorder, and so on.

■ Block Diagram

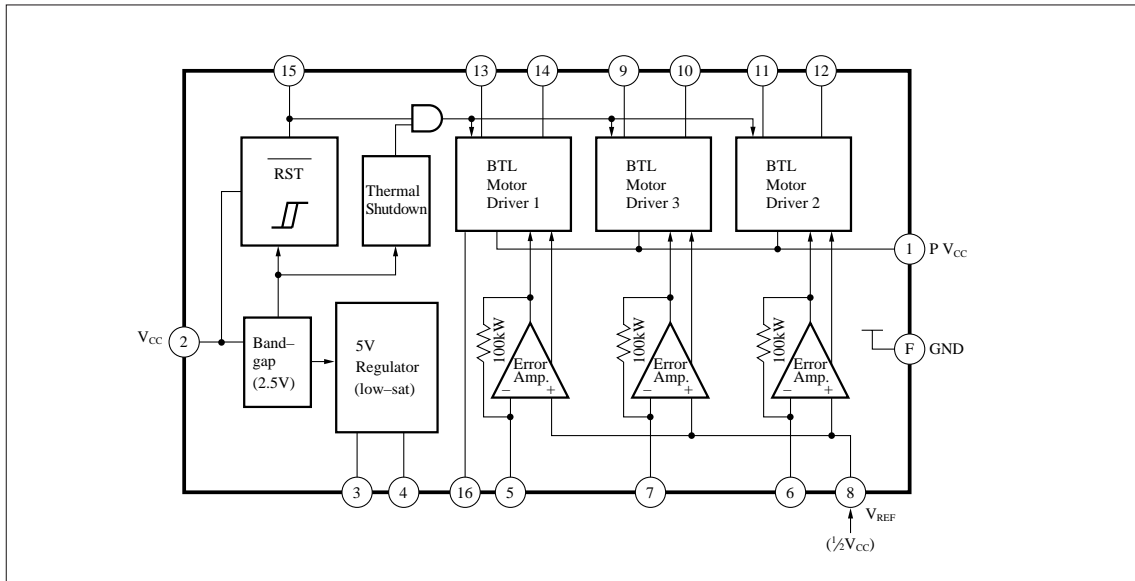

■ Absolute Maximum Ratings (Ta=25°C)

Parameter	Symbol	Rating	Unit
Supply Voltage	V _{CC}	20	V
Power Dissipation	P _D	1500	mW
Operating Ambient Temperature	T _{opr}	-25 ~ +80	°C
Storage Temperature	T _{stg}	-55 ~ +150	°C

■ Recommended Operating Range (Ta=25°C)

Parameter	Symbol	Range
Operating Supply Voltage Range	V _{CC}	5.5V ~ 16V

■ Electrical Characteristics (Ta=25°C)

Parameter	Symbol	Condition	min.	typ.	max.	Unit
No Load Current	I _{CC}	V _{CC} =12V	7	10.5	15	mA
5V Regulator Output Voltage	V _{RO}	V _{CC} =12V, R _L =50W	4.75	5	5.25	V
5V Regulator Load Change	DV _{RI}	V _{CC} =12V, R _L =50W ~ 25W	-15	—	30	mV
5V Regulator Input Change	DV _{RVC}	V _{CC} =15.5V ~ 5.5V, R _L =50W	-15	—	50	mV
Reset Threshold Voltage	V _{RST}		4.55	4.82	5.1	V
Reset Threshold Hysteresis Width	V _{HYS}		90	170	310	mV
Reset Operating Minimum Voltage	V _{R (min.)}	Minimum V _{CC} Voltage at which V15=Low	3.1	—	—	V
Input Offset Voltage	V _{IOF}	V _{CC} =18V, R _L =20W, R _{IN} =10kW	-7	—	7	mV
Output Offset Voltage	V _{OOF}	V _{CC} =18V, R _L =20W, R _{IN} =10kW	-50	—	50	mV
Gain (+)	G ₊	V _{CC} =18V, R _L =20W, R _{IN} =10kW	16.5	20	22.5	dB
(+) (-) Relative Gain	G _R	V _{CC} =18V, R _L =20W, R _{IN} =10kW	-0.85	—	0.85	dB
Limit Voltage (+)	V _{L+}	V _{CC} =18V, R _L =20W, R _{IN} =10kW	7.1	—	10.9	V
Limit Voltage (-)	V _{L-}	V _{CC} =18V, R _L =20W, R _{IN} =10kW	-10.9	—	-7.1	V
Dead Zone Width	V _{DZ}	V _{CC} =18V, R _L =20W, R _{IN} =10kW	-10	—	30	mV
PC Input Threshold (L)	V _{PCL}	V _{CC} =18V	—	—	1.2	V
PC Input Threshold (H)	V _{PCH}	V _{CC} =18V	2.8	—	—	V
Motor Driver 2 Output Voltage at Reset	V _{2RS}	V _{CC} =3.5V, R _L =10kW	-50	—	50	mV
Motor Driver 3 Output Voltage at Reset	V _{3RS}	V _{CC} =3.5V, R _L =10kW	-50	—	50	mV
Motor Driver 1 Output Voltage at Reset	V _{1RS}	V _{CC} =3.5V, R _L =10kW	-50	—	50	mV
5V Regulator External Transistor Base Current Limit Value	I _{3LIM}		9	12	16	mA
Thermal Protective Circuit Operating Temperature Balancing Value	T _{THD}		—	159	—	°C
Thermal Protective Circuit Operating Temperature Hysteresis Width	DT _{THD}		—	64	—	°C

Note) The specified values of V_{IOF}, V_{OOF}, G₊, G_R, V_{L+}, V_{L-}, and V_{DZ} are common ones for each of the motor driver 1, motor driver 2, and motor driver 3 circuits.

■ Pin Descriptions (Cont.) (The following description applies when the 3 channels for the motor drivers 1, 2, and 3 are used.)

Pin No.	Symbol	I/O	DC Voltage ($V_{CC}/12V$)	Equivalent Circuit	Description	
15	\overline{RST}	O	—		Reset output pin. Open collector output type.	
F	GND	I	0V		GND pin	
8	V_{REF}	I	2.5V		V_{REF} input pin	
5	TVDI	I	2.5V		Driver 1 error input pin	
6	FDI	I	2.5V		Driver 2 error input pin	
7	TDI	I	2.5V		Driver 3 error input pin	
9	TD-	O	(0.3V)		BTL driver 3 inverting output pin	
10	TD+	O	(0.3V)		BTL driver 3 non-inverting output pin	
11	FD-	O	(0.3V)		BTL driver 2 inverting output pin	
12	FD+	O	(0.3V)		BTL driver 2 non-inverting output pin	
13	TVD-	O	(0V)		BTL driver 1 inverting output pin	
14	TVD+	O	(0V)		BTL driver 1 non-inverting output pin	
16	PC	I	0V			PC (power cut) input pin



LittleDiode supplies new, hard to find or obsolete electronic components and semiconductors all over the world.

With over two million different components listed you are sure to find the part you need.

Feel free to visit us today at our online store:

LittleDiode.com

Looking forward to providing you with the best possible service.