

## 2N7002-G (N-Channel) RoHS Device



### Features

Power dissipation : 0.35W

### Equivalent Circuit

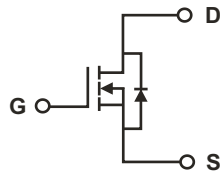

G : Gate  
S : Source  
D : Drain

### Maximum Ratings (at TA=25°C)

Parameter	Symbol	Value	Unit
Drain-Source voltage	$V_{DS}$	60	V
Drain current	$I_D$	250	mA
Power dissipation	$P_D$	350	mW
Junction and storage temperature	$T_J, T_{STG}$	-55 ~ +150	°C

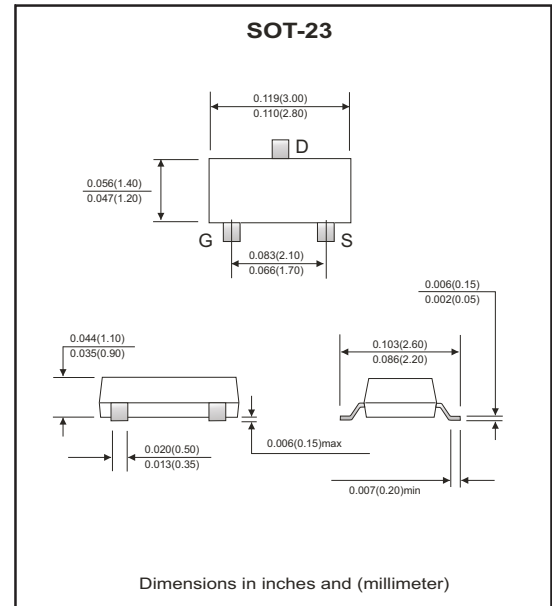

### Electrical Characteristics (at TA=25°C unless otherwise noted)

Parameter	Conditions	Symbol	Min	Typ	Max	Unit
Drain-Source breakdown voltage	$V_{GS}=0V, I_D=10\mu A$	$V_{(BR)DS}$	60	70		V
Gate-Threshold voltage	$V_{DS}=V_{GS}, I_D=250\mu A$	$V_{th(GS)}$	1	1.5	2.5	
Gate-body leakage	$V_{DS}=0V, V_{GS}=15V$	$I_{GSS}$			10	nA
Zero gate voltage drain current	$V_{DS}=60V, V_{GS}=0V$	$I_{DSS}$			1	$\mu A$
	$V_{DS}=60V, V_{GS}=0V, T_J=125^\circ C$				500	
On-state drain current	$V_{GS}=10V, V_{DS}=7.5V$	$I_{D(ON)}$	800	1300		mA
	$V_{GS}=4.5V, V_{DS}=10V$		500	700		
Drain-Source on resistance	$V_{GS}=10V, I_D=250mA$	$r_{DS(ON)}$		1.5	3	$\Omega$
	$V_{GS}=4.5V, I_D=200mA$			2.0	4	
Forward tran conductance	$V_{DS}=15V, I_D=200mA$	$g_{fs}$		300		mS
Diode forward voltage	$I_S=200mA, V_{GS}=0V$	$V_{SD}$		0.85	1.2	V
Total gate charge	$V_{DS}=30V, V_{GS}=10V, I_D=250mA$	$Q_g$		0.6	1.0	nC
Gate-Source charge		$Q_{gs}$		0.06		
Gate-Drain charge		$Q_{gd}$		0.06		
Input capacitance	$V_{DS}=25V, V_{GS}=0V, f=1MHz$	$C_{iss}$		25		pF
Output capacitance		$C_{oss}$		6		
Reverse transfer capacitance		$C_{rss}$		1.2		
Turn-on time	$V_{DD}=30V, R_L=200\Omega, I_D=100mA, V_{GEN}=10V, R_G=10\Omega$	$t_{d(ON)}$		7.5	20	nS
		$t_r$		6		
Turn-off time		$t_{d(off)}$		7.5	20	

## RATING AND CHARACTERISTIC CURVES (2N7002-G)

Fig.1 On-Region Characteristics

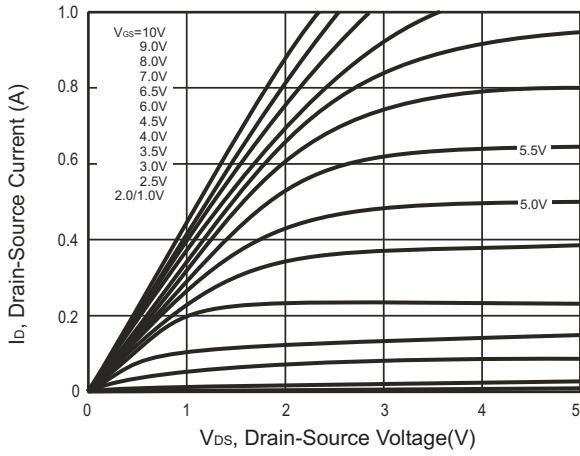

Fig.2 On-Resistance vs Drain Current

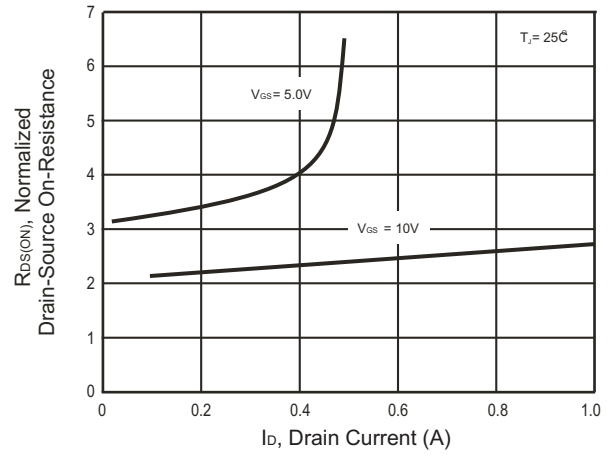

Fig.3 On-Resistance vs Junction Temperature

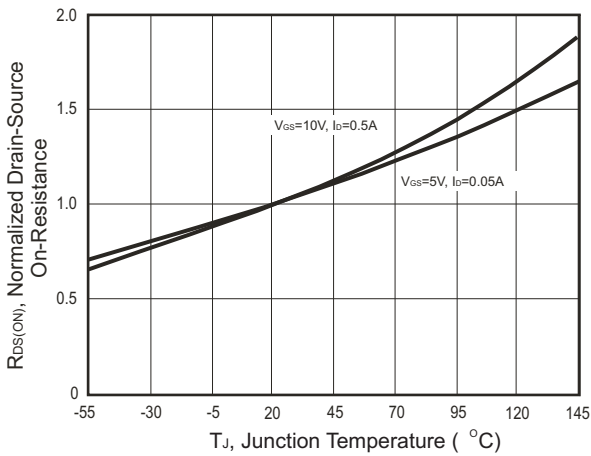
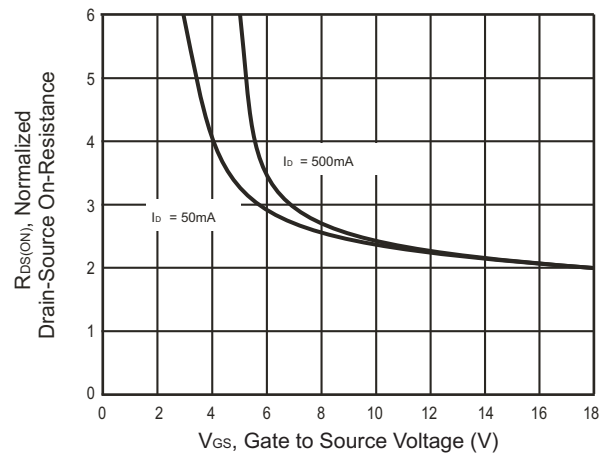
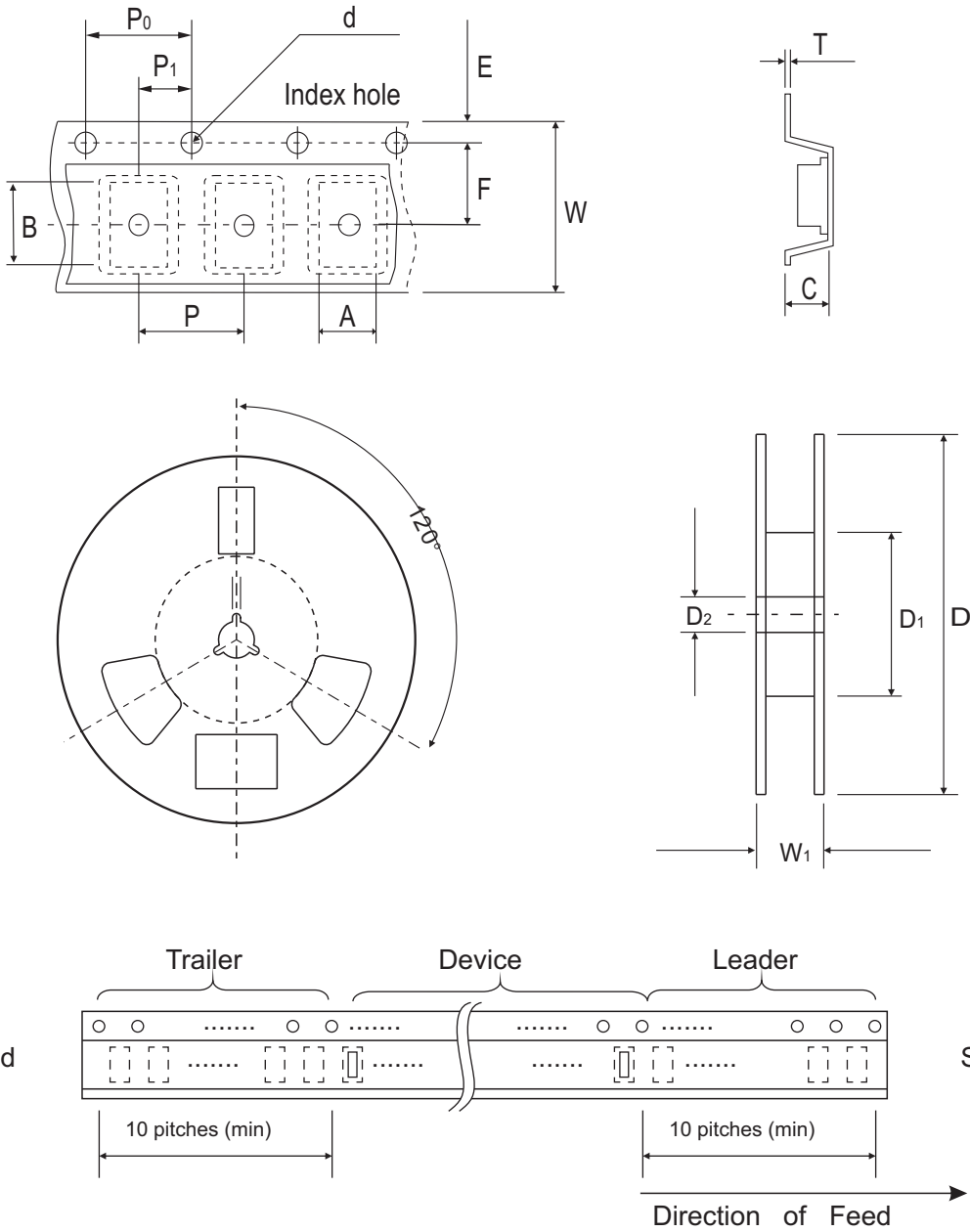

Fig.4 On-Resistance vs Gate-Source Voltage



## Reel Taping Specification



SOT-23	SYMBOL	A	B	C	d	D	D <sub>1</sub>	D <sub>2</sub>
	(mm)	3.10 ± 0.10	2.85 ± 0.10	1.40 ± 0.10	1.55 ± 0.10	178 ± 1	50.0 MIN.	13.0 ± 0.20
	(inch)	0.122 ± 0.004	0.112 ± 0.004	0.055 ± 0.004	0.061 ± 0.004	7.008 ± 0.04	1.969 MIN.	0.512 ± 0.008

SOT-23	SYMBOL	E	F	P	P <sub>0</sub>	P <sub>1</sub>	W	W <sub>1</sub>
	(mm)	1.75 ± 0.10	3.50 ± 0.05	4.00 ± 0.10	4.00 ± 0.10	2.00 ± 0.05	8.00 ± 0.30	14.4 MAX.
	(inch)	0.069 ± 0.004	0.138 ± 0.002	0.157 ± 0.004	0.157 ± 0.004	0.079 ± 0.002	0.315 ± 0.012	0.567 MAX.

## Marking Code

Part Number	Marking Code
2N7002-G	7002

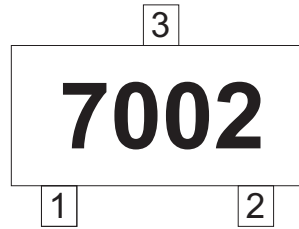

## Suggested PAD Layout

SIZE	SOT-23	
	(mm)	(inch)
A	0.80	0.031
B	1.90	0.075
C	2.02	0.080
D	2.82	0.111

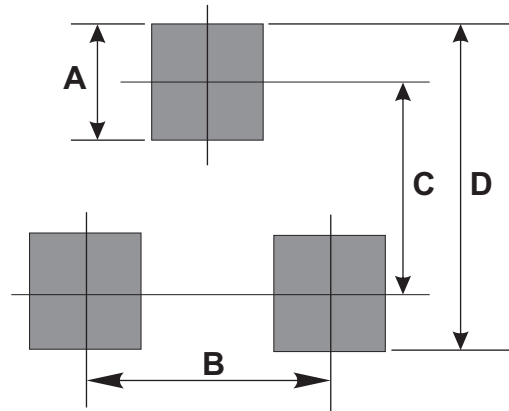

## Standard Packaging

Case Type	REEL PACK	
	REEL ( pcs )	Reel Size (inch)
SOT-23	3,000	7



LittleDiode supplies new, hard to find or obsolete electronic components and semiconductors all over the world.

With over two million different components listed you are sure to find the part you need.

Feel free to visit us today at our online store:

[LittleDiode.com](http://LittleDiode.com)

Looking forward to providing you with the best possible service.