

MECHANICAL DATA

Dimensions in mm (inches)

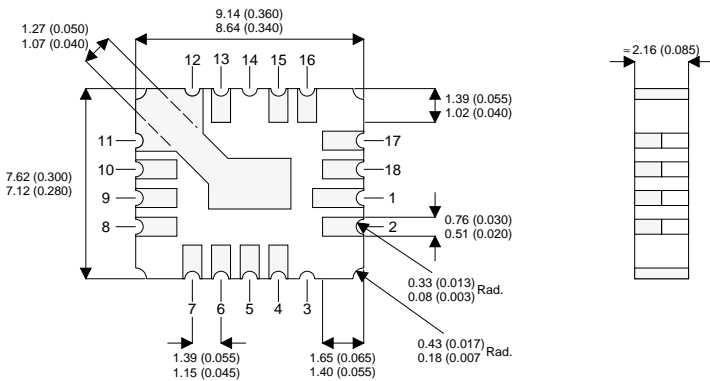

LCC4

MOSFET	TRANSISTOR	PINS
GATE	BASE	4,5
DRAIN	COLLECTOR	1,2,15,16,17,18
SOURCE	EMITTER	6,7,8,9,10,11,12,13

**N-CHANNEL
POWER MOSFET**

V_{DSS}	100V
$I_{D(cont)}$	3.1A
$R_{DS(on)}$	0.6Ω

FEATURES

- SURFACE MOUNT
- SMALL FOOTPRINT
- HERMETICALLY SEALED
- DYNAMIC dv/dt RATING
- AVALANCHE ENERGY RATING
- SIMPLE DRIVE REQUIREMENTS
- LIGHTWEIGHT

ABSOLUTE MAXIMUM RATINGS ($T_{case} = 25^{\circ}C$ unless otherwise stated)

V_{GS}	Gate – Source Voltage	$\pm 20V$
I_D	Continuous Drain Current ($V_{GS} = 10V, T_{case} = 25^{\circ}C$)	3.1A
I_D	Continuous Drain Current ($V_{GS} = 10V, T_{case} = 100^{\circ}C$)	2.0A
I_{DM}	Pulsed Drain Current ¹	12A
P_D	Power Dissipation @ $T_{case} = 25^{\circ}C$	11W
	Linear Derating Factor	0.09W/ $^{\circ}C$
E_{AS}	Single Pulse Avalanche Energy ²	68mJ
dv/dt	Peak Diode Recovery ³	5.5V/ns
T_J, T_{stg}	Operating and Storage Temperature Range	-55 to +150 $^{\circ}C$
	Surface Temperature (for 5 sec).	300 $^{\circ}C$

Notes

- 1) Pulse Test: Pulse Width $\leq 300\mu s$, $\delta \leq 2\%$
- 2) @ $V_{DD} = 50V$, $L \geq 570\mu H$, $R_G = 25\Omega$, Peak $I_L = 14A$, Starting $T_J = 25^{\circ}C$
- 3) @ $I_{SD} \leq 14A$, $di/dt \leq 140A/\mu s$, $V_{DD} \leq BV_{DSS}$, $T_J \leq 150^{\circ}C$, Suggested $R_G = 7.5\Omega$

ELECTRICAL CHARACTERISTICS ($T_{case} = 25^{\circ}C$ unless otherwise stated)

Parameter	Test Conditions	Min.	Typ.	Max.	Unit
STATIC ELECTRICAL RATINGS					
BV_{DSS}	Drain – Source Breakdown Voltage	$V_{GS} = 0$ $I_D = 1mA$	100		V
$\frac{\Delta BV_{DSS}}{\Delta T_J}$	Temperature Coefficient of Breakdown Voltage	Reference to $25^{\circ}C$ $I_D = 1mA$		0.10	$V/^{\circ}C$
$R_{DS(on)}$	Static Drain – Source On-State Resistance ¹	$V_{GS} = 10V$ $I_D = 2A$		0.6	Ω
		$V_{GS} = 10V$ $I_D = 3.1A$		0.69	
$V_{GS(th)}$	Gate Threshold Voltage	$V_{DS} = V_{GS}$ $I_D = 250mA$	2	4	V
g_{fs}	Forward Transconductance ¹	$V_{DS} \geq 15V$ $I_{DS} = 2A$	0.8		S (\bar{O})
I_{DSS}	Zero Gate Voltage Drain Current	$V_{GS} = 0$ $V_{DS} = 0.8BV_{DSS}$ $T_J = 125^{\circ}C$		25	μA
				250	
I_{GSS}	Forward Gate – Source Leakage	$V_{GS} = 20V$		100	nA
I_{GSS}	Reverse Gate – Source Leakage	$V_{GS} = -20V$		-100	
DYNAMIC CHARACTERISTICS					
C_{iss}	Input Capacitance	$V_{GS} = 0$		180	pF
C_{oss}	Output Capacitance	$V_{DS} = 25V$		82	
C_{rss}	Reverse Transfer Capacitance	$f = 1MHz$		15	
Q_g	Total Gate Charge	$V_{GS} = 10V$	4.1	6.5	nC
Q_{gs}	Gate – Source Charge	$I_D = 3.1A$	0.4	1.6	
Q_{gd}	Gate – Drain (“Miller”) Charge	$V_{DS} = 0.5BV_{DSS}$	1.4	3.5	
$t_{d(on)}$	Turn–On Delay Time	$V_{DD} = 50V$ $I_D = 3.1A$ $R_G = 7.5\Omega$		15	ns
t_r	Rise Time			25	
$t_{d(off)}$	Turn–Off Delay Time			25	
t_f	Fall Time			20	
SOURCE – DRAIN DIODE CHARACTERISTICS					
I_S	Continuous Source Current			3.1	A
I_{SM}	Pulse Source Current ²			12	
V_{SD}	Diode Forward Voltage ¹	$I_S = 3.1A$ $T_J = 25^{\circ}C$ $V_{GS} = 0$		1.5	V
t_{rr}	Reverse Recovery Time	$I_F = 7.4A$ $T_J = 25^{\circ}C$		180	ns
Q_{rr}	Reverse Recovery Charge ¹	$d_i / d_t \leq 100A/\mu s$ $V_{DD} \leq 50V$		2.0	μC
t_{on}	Forward Turn–On Time		Negligible		
THERMAL CHARACTERISTICS					
$R_{\theta JC}$	Thermal Resistance Junction – Case			11	$^{\circ}C/W$
$R_{\theta JPC}$	Thermal Resistance Junction – PC Board			27	

Notes

- 1) Pulse Test: Pulse Width $\leq 300ms$, $\delta \leq 2\%$
- 2) Repetitive Rating – Pulse width limited by maximum junction temperature.



LittleDiode supplies new, hard to find or obsolete electronic components and semiconductors all over the world.

With over two million different components listed you are sure to find the part you need.

Feel free to visit us today at our online store:

LittleDiode.com

Looking forward to providing you with the best possible service.