

FAIRCHILD

A Schlumberger Company

2N6761/2N6762
N-Channel Power MOSFETs,
4.5 A, 450 V/500 V

T-39-11

Power And Discrete Division

Description

These devices are n-channel, enhancement mode, power MOSFETs designed especially for high voltage, high speed applications, such as off-line switching power supplies, UPS, AC and DC motor controls, relay and solenoid drivers.

TO-204AA

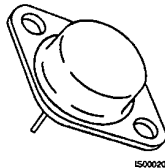

2N6761
 2N6762

- V_{GS} Rated at ± 20 V
- Silicon Gate for Fast Switching Speeds
- I_{DSS} , $R_{DS(on)}$, SOA and $V_{GS(th)}$ Specified at Elevated Temperature
- Rugged

Maximum Ratings

Symbol	Characteristic	Rating 2N6762	Rating 2N6761	Unit
V_{DSS}	Drain to Source Voltage	500	450	V
V_{DGR}	Drain to Gate Voltage $R_{GS} = 1.0 \text{ M}\Omega$	500	450	V
V_{GS}	Gate to Source Voltage	± 20	± 20	V
T_J, T_{stg}	Operating Junction and Storage Temperatures	-55 to +150	-55 to +150	$^{\circ}\text{C}$
T_L	Maximum Lead Temperature for Soldering Purposes, 1/16" From Case for 10 s	300	300	$^{\circ}\text{C}$

Maximum On-State Characteristics

$R_{DS(on)}$	Static Drain-to-Source On Resistance	1.5	2.0	Ω
I_D	Drain Current Continuous at $T_C = 25^{\circ}\text{C}$ Continuous at $T_C = 100^{\circ}\text{C}$	4.5 3.0	4.0 2.5	A
I_{DM}	Pulsed	7.0^2	6.0^2	

Maximum Thermal Characteristics

$R_{\theta JC}$	Thermal Resistance, Junction to Case	1.67	1.67	$^{\circ}\text{C}/\text{W}$
P_D	Total Power Dissipation at $T_C = 25^{\circ}\text{C}$ at $T_C = 100^{\circ}\text{C}$	75 30	75 30	W
	Linear Derating Factor	0.6	0.6	W/ $^{\circ}\text{C}$

Notes

All values are JEDEC registered except as noted. For information concerning connection diagram and package outline, refer to Section 7.

Electrical Characteristics ($T_C = 25^\circ\text{C}$ unless otherwise noted)

Symbol	Characteristic	Min	Max	Unit	Test Conditions
Off Characteristics					
$V_{(BR)DSS}$	Drain Source Breakdown Voltage ¹ 2N6762 2N6761			V	$V_{GS} = 0\text{ V}, I_D = 4\text{ mA}$
		500 ²			
		450 ²			
I_{DSS}	Zero Gate Voltage Drain Current		1	mA	$V_{DS} = \text{Rated } V_{DSS}, V_{GS} = 0\text{ V}$ $V_{DS} = 0.8 \times \text{Rated } V_{DSS}, V_{GS} = 0\text{ V}, T_C = 125^\circ\text{C}$
			4		
I_{GSS}	Gate-Body Leakage Current		± 100	nA	$V_{GS} = \pm 20\text{ V}, V_{DS} = 0\text{ V}$
On Characteristics					
$V_{GS(th)}$	Gate Threshold Voltage	2.0	4.0	V	$I_D = 1.0\text{ mA}, V_{DS} = V_{GS}$
$R_{DS(on)}$	Static Drain-Source On-Resistance ¹ 2N6762 2N6761 2N6762 2N6761			Ω	$V_{GS} = 10\text{ V}$ $I_D = 3.0\text{ A}$ $I_D = 2.5\text{ A}$ $I_D = 3.0\text{ A}, T_C = 125^\circ\text{C}$ $I_D = 2.5\text{ A}, T_C = 125^\circ\text{C}$
			1.5		
			2.0		
			3.3		
			4.4		
$V_{DS(on)}$	Drain-Source On-Voltage ¹ 2N6762 2N6761		7.7	V	$V_{GS} = 10\text{ V}$ $I_D = 4.5\text{ A}$ $I_D = 4.0\text{ A}$
			8.0		
g_{fs}	Forward Transconductance ¹	2.5	7.5	S (Ω)	$V_{DS} = 15\text{ V}, I_D = 3.0\text{ A}$
Dynamic Characteristics					
C_{iss}	Input Capacitance	350	800	pF	$V_{DS} = 25\text{ V}, V_{GS} = 0\text{ V}$ $f = 1.0\text{ MHz}$
C_{dss}	Output Capacitance	25	200	pF	
C_{res}	Reverse Transfer Capacitance	15	60	pF	
Switching Characteristics ($T_C = 25^\circ\text{C}$, Figures 9, 10)					
$t_{d(on)}$	Turn-On Delay Time		30	ns	$V_{DD} = 225\text{ V}, I_D = 3.0\text{ A}$ $V_{GS} = 10\text{ V}, R_{GEN} = \Omega$ $R_{GS} = 15\ \Omega$
t_r	Rise Time		30	ns	
$t_{d(off)}$	Turn-Off Delay Time		55	ns	
t_f	Fall Time		30	ns	
Q_g	Total Gate Charge		30 ²	nC	$V_{GS} = 10\text{ V}, I_D = 7.0\text{ A}$ $V_{DD} = 180\text{ V}$

Electrical Characteristics (Cont.) ($T_C = 25^\circ\text{C}$ unless otherwise noted)

Symbol	Characteristic	Min	Typ	Max	Unit	Test Conditions
Source-Drain Diode Characteristics						
I_S	Continuous Source Current 2N6762 2N6761			4.5 4.0	A	
I_{SM}	Pulsed Source Current 2N6762 2N6761			7.0 6.0	A	
V_{SD}	Diode Forward Voltage 2N6762 2N6761	0.7 0.65		1.4 1.3	V	$V_{GS} = 0\text{ V}$ $I_S = 4.5\text{ A}$ $I_S = 4.0\text{ A}$
t_{rr}	Reverse Recovery Time		520^2		ns	$V_{GS} = 0\text{ V}$, $T_J = 150^\circ\text{C}$ $I_F = I_{SM}$, $dI_F/dt = 100\text{ A}/\mu\text{S}$
Q_{RR}	Reverse Recovery Charge		7.0^2		μC	$V_{GS} = 0\text{ V}$, $T_J = 150^\circ\text{C}$ $I_F = I_{SM}$, $dI_F/dt = 100\text{ A}/\mu\text{S}$

Notes

1. Pulse test: Pulse width $\leq 300\ \mu\text{s}$, Duty cycle $\leq 1\%$
2. Non-JEDEC registered value.

Typical Performance Curves

Figure 1 Output Characteristics

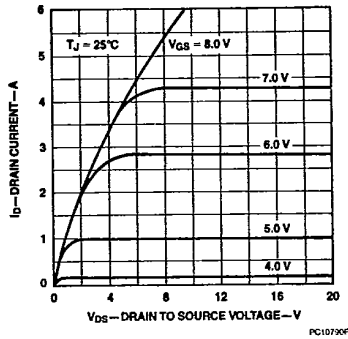
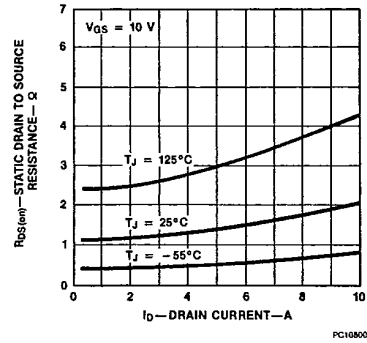

Figure 2 Static Drain to Source Resistance vs Drain Current



2N6761/2N6762

T-39-11

Typical Performance Curves (Cont.)

Figure 3 Transfer Characteristics

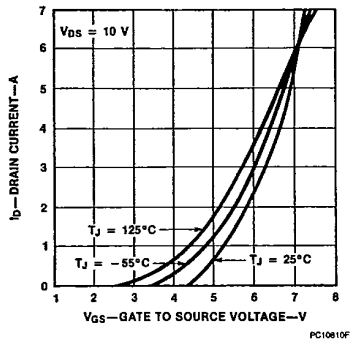

Figure 4 Temperature Variation of Gate to Source Threshold Voltage

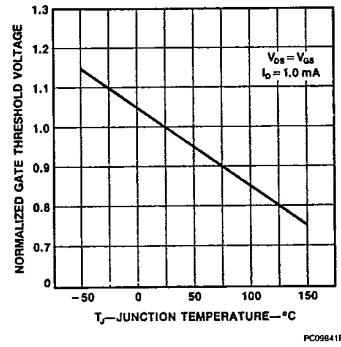

Figure 5 Capacitance vs Drain to Source Voltage

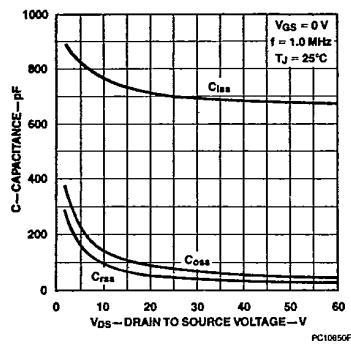

Figure 6 Gate to Source Voltage vs Total Gate Charge

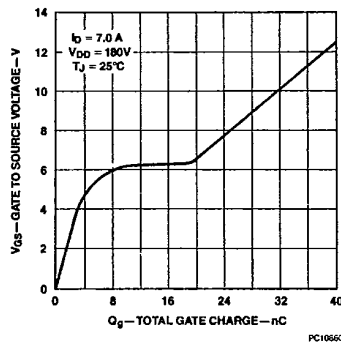

Figure 7 Forward Biased Safe Operating Area

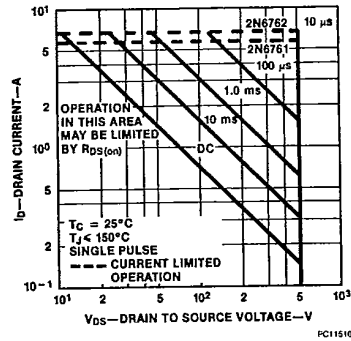
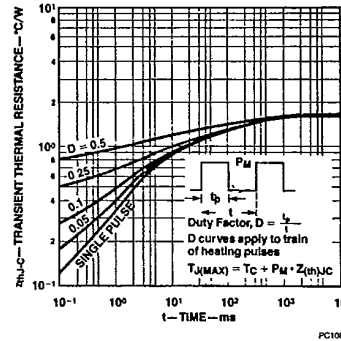
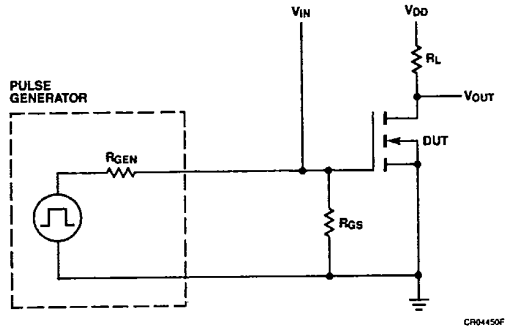

Figure 8 Transient Thermal Resistance vs Time



Typical Electrical Characteristics

Figure 9 Switching Test Circuit



CR0450F

Figure 10 Switching Waveforms

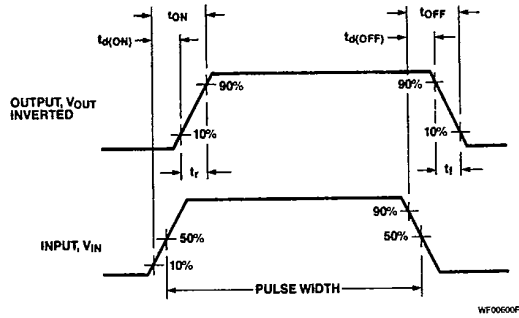

WF00000F

This datasheet has been downloaded from:

www.DatasheetCatalog.com

Datasheets for electronic components.



LittleDiode supplies new, hard to find or obsolete electronic components and semiconductors all over the world.

With over two million different components listed you are sure to find the part you need.

Feel free to visit us today at our online store:

LittleDiode.com

Looking forward to providing you with the best possible service.