

# HA12413

## FM/AM IF SYSTEM

The HITACHI HA12413 is an IC for FM/AM IF system. Typical applications include cassette radios and modular stereos, functioning and featuring as follows.

### FUNCTIONS

#### FM ● IF Amplifier

(With C.F. is inserted between the stages)

- Audio Amplifier
- Quadrature Detector
- Signal Meter  
(One external NPN transistor required. Used also for AM)
- Center Meter

#### AM ● IF Amplifier (With AGC)

- Detector
- Signal Meter  
(Same pin with FM)

### FEATURES

#### FM ● High Limiting Sensitivity, and High Stability (33dB $\mu$ )

- Low Residual Noise (-45dB at Vin=-10dB $\mu$ )
- Small Side Peak of Detuned Output Voltage  
(Peak Level is approx. +2dB in comparison with that of Center Frequency)
- Muting Available at lower input level  
(One external PNP transistor required)

#### AM ● Voltage Regulator for RF external Circuit

- High AGC Figure of merit

#### FM/AM

- Low Operating Current (FM: 11mA, AM:8mA)
- Wide Range of Operating Supply Voltage (3V~16V)
- Low External Parts count

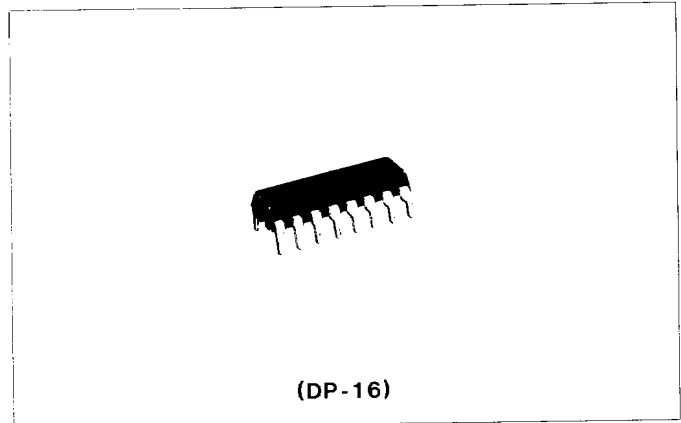

### BLOCK DIAGRAM & TYPICAL APPLICATION CIRCUIT

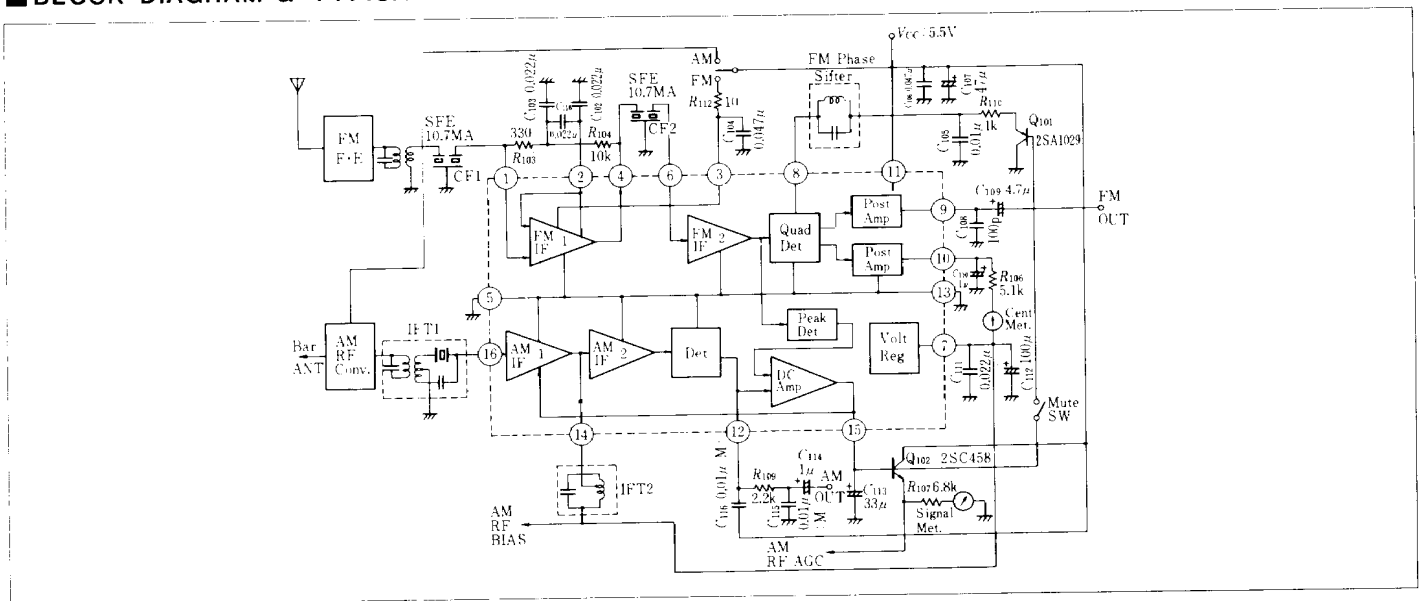

### ABSOLUTE MAXIMUM RATINGS (Ta=25°C, unless otherwise specified)

Item	Symbol	Rating	Unit
Supply Voltage	V <sub>CC</sub>	16	V
Power Dissipation	P <sub>T</sub> *	350	mW
Operating Temperature Range	T <sub>OP</sub>	-20 to +70	°C
Storage Temperature Range	T <sub>STG</sub>	-55 to +125	°C

\*Value at Ta=70°C



(at  $T_a=25^\circ\text{C}$  unless otherwise specified, the test conditions are:  
 FM:  $V_{CC}=5.5\text{V}$ ,  $f_c=10.7\text{MHz}$ ,  $f_m=1\text{kHz}$ ,  $\Delta f=75\text{kHz}$   
 AM:  $V_{CC}=5.5\text{V}$ ,  $f_c=455\text{kHz}$ ,  $f_m=1\text{kHz}$ ,  $m=30\%$ )

■ ELECTRICAL CHARACTERISTICS

	Item	Symbol	Test Conditions	min.	typ.	max.	Unit
FM	Operating Current	$I_{CC}$	$V_{CC}=5.5\text{V}$ , No Input	7	11	16.5	mA
	Audio Output Voltage	$V_{O:AF}$	$V_{in}=100\text{dB}\mu$	180	245	310	mV
	Total Harmonic Distortion	T.H.D.	$V_{in}=100\text{dB}\mu$	—	0.3	1.0	%
	Limiting Sensitivity	$V_{(in:lim)}$	the value of input to make output lower by 3dB	—	33	38	$\text{dB}\mu$
	Signal-to-Noise Ratio	S/N	$V_{in}=100\text{dB}\mu$	72	83	—	dB
	AM Rejection Ratio	AMR	$V_{in}=100\text{dB}\mu$ , AM Modulation: $f_m=1\text{kHz}$ , $m=30\%$	50	60	—	dB
	Signal Meter Output Voltage	$V_M$	$V_{in}=100\text{dB}\mu$	1.05	1.5	2.05	V
	Residual Noise	$V_N$	Noise level with $V_{in}=-10\text{dB}\mu$ to Audio Output Voltage with $V_{in}=100\text{dB}\mu$	—	45	—	dB
AM	Muting Attenuation	$Mute_{(ATT)}$	$V_{in}=37\text{dB}\mu$ , Mute SW: ON	—	35	—	dB
	Total Harmonic Distortion	T.H.D.(1)	$V_{in}=74\text{dB}\mu$	—	0.3	2.0	%
	Total Harmonic Distortion	T.H.D.(2)	$V_{in}=100\text{dB}\mu$	—	0.7	3.5	%
	Signal-to-Noise Ratio	S/N	$V_{in}=74\text{dB}\mu$	45	55	—	dB
	Maximum Sensitivity	$S_{IF}$	the value of input to make $V_{O:AF}=10\text{mV}$	—	29	—	$\text{dB}\mu$
	Signal Meter Output Voltage	$V_M$	$V_{in}=100\text{dB}\mu$	1.2	1.4	1.6	V
	Audio Output Voltage	$V_{O:AF}$	$V_{in}=74\text{dB}\mu$	45	65	85	mV
	Input Impedance at 16 pin	$Z_{in16}$	DC measurement	1.45	2.12	2.8	$\text{k}\Omega$

■ TEST CIRCUIT

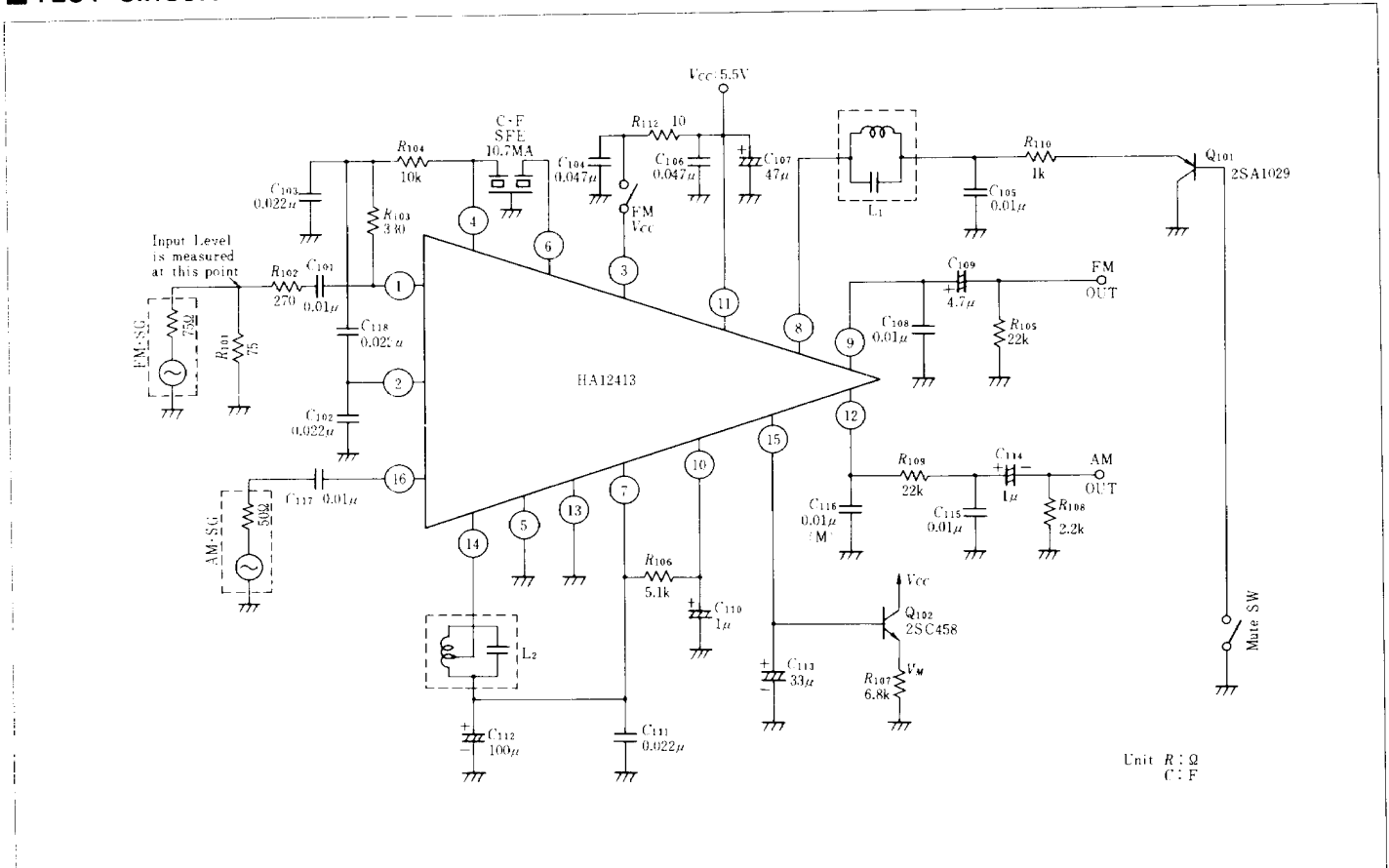

INPUT AND OUTPUT CIRCUIT OF EACH PIN

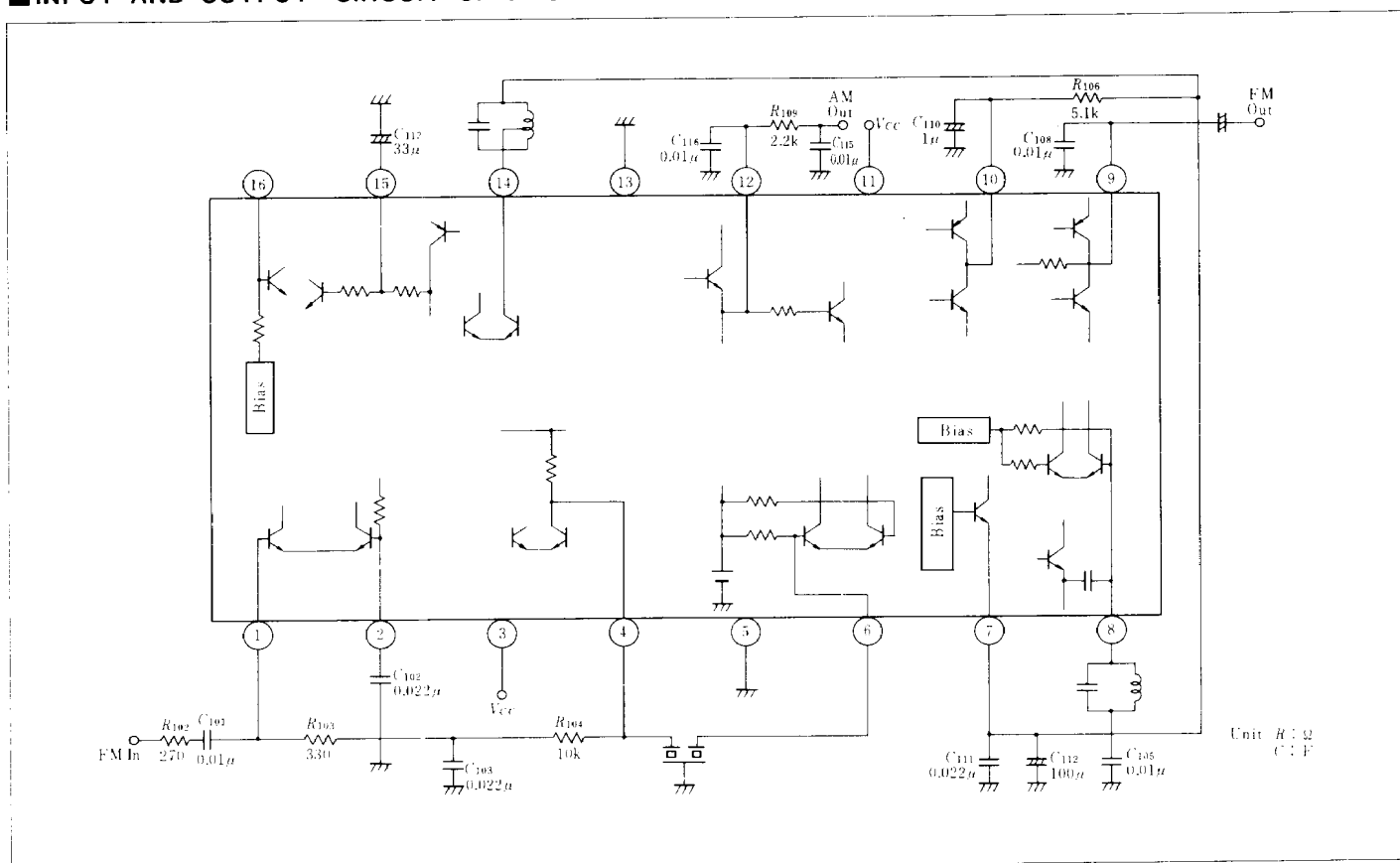

EXTERNAL COMPONENTS

1. Resistor

Part No.	Recommended Value	Function	Influence		Note
			Less than Recommended Value	More than Recommended Value	
R <sub>101</sub>	75Ω	SG Impedance Matching	—	—	Only for test circuit
R <sub>102</sub>	270Ω	Input Impedance Matching	—	—	Only for test circuit
R <sub>103</sub>	330Ω	Impedance Matching to Intermediate Frequency Filter	—	—	—
R <sub>104</sub>	10kΩ	IF Amp. DC Feedback	Offset of Defferential Voltage: High	Offset of Defferential Voltage: High	—
R <sub>105</sub>	22kΩ	Load Resistor for FM Detective Output	Detective Output: Low	Detective Output: High	Only for test circuit
R <sub>106</sub>	5.1kΩ	Load Resistor for AFC Voltage	AFC Voltage: Low	AFC Voltage: High	—
R <sub>107</sub>	6.8kΩ	Meter Operating Current Limiting	Meter Swing: Large	Meter Swing Small	Decided by the Meter Rating
R <sub>108</sub>	22kΩ	Load Resistor for AM Detective Output	Detective Output: Low	—	Only for test circuit
R <sub>109</sub>	2.2kΩ	L. P. F. Forming (With C <sub>115</sub> )	Carrier Leak: Large	Frequency Characteristics of Detective Output: Deteriorate	—
R <sub>110</sub>	1kΩ	Mute-ON-Current Limiting	IC Breakdown	Mute Attenuation: Deteriorate	—
R <sub>112</sub>	10Ω	Decoupling (With C <sub>104</sub> )	Unstabilizing	Voltage-Abating Characteristics: Deteriorate	—

2. Condensor

Part No.	Recommended Value	Functions	Influence		Note
			Less than the Recommended Value	More than the Recommended Value	
C <sub>101</sub>	0.01 $\mu$	Input DC Cut	Deterioration of Sensitivity	—	—
C <sub>102</sub>	0.022 $\mu$	Input Decoupling	Unstabilizing	—	—
C <sub>103</sub>	0.022 $\mu$	Input Decoupling	Unstabilizing	—	—
C <sub>104</sub>	0.047 $\mu$	FM V <sub>cc</sub> Supply Decoupling	Unstabilizing	—	—
C <sub>105</sub>	0.01 $\mu$	Detector Decoupling	Unstabilizing	—	—
C <sub>106</sub>	0.047 $\mu$	Power Supply Decoupling	Unstabilizing	—	—
C <sub>107</sub>	47 $\mu$	Power Supply Decoupling	Superposing of Low Frequency Signal	—	—
C <sub>108</sub>	0.01 $\mu$	De-emphasis (With 9pin Output Impedance)	Deterioration of De-emphasis Characteristics	Deterioration of De-emphasis Characteristics	C <sub>108</sub> =100 pF, for Stereo Use
C <sub>109</sub>	4.7 $\mu$	FM Output DC Cut	Separation Deteriorating in Low Frequency Range	—	—
C <sub>110</sub>	1 $\mu$	AFC Output Decoupling	Low Frequency Signal Superposing on AFC Controlling Line	Long time is required for AFC operation to start	—
C <sub>111</sub>	0.022 $\mu$	Voltage Regulator Decoupling	Unstabilizing	—	—
C <sub>112</sub>	100 $\mu$	FM $\leftrightarrow$ AM Crosstalk Decreasing	Large Crosstalk	—	—
C <sub>113</sub>	33 $\mu$	AGC Decoupling	THD Deterioration at AM Low Frequency Range	Long time is required for AGC operation to start	—
C <sub>114</sub>	1 $\mu$	AM Output DC Cut	Deterioration of Frequency Characteristic in Low Frequency Range	—	—
C <sub>115</sub>	0.01 $\mu$	LPF Forming (With R 109)	Large Carrier Leak	Deterioration of Frequency Characteristic of Recovered Audio Voltage	—
C <sub>116</sub>	0.01 $\mu$	AM Detecting		—	Use Polyester Film Capacitor
C <sub>117</sub>	0.01 $\mu$	AM Input DC Cut	Deterioration of Sensitivity	—	—
C <sub>118</sub>	0.022 $\mu$	Input Decoupling	Unstabilizing	—	—

3. Semiconductor

- \* Q<sub>101</sub> : 2SA1029 (Transistor for Muting)
  - \* Q<sub>102</sub> : 2SC458 $\text{\textcircled{B}}$  (Transistor for Signal Meter Drive)
- Note) V<sub>BE</sub> at Q<sub>102</sub> 2SC458 $\text{\textcircled{B}}$  (When 100 $\mu$ A emitter current supplied):  
606 mV typ.

4. Coil/Filter

- 1) Ceramic Filter Murata SFE 10.7MA
- 2) Coil

L2 (FM Det Coil) Mitsumi No.MB-90438

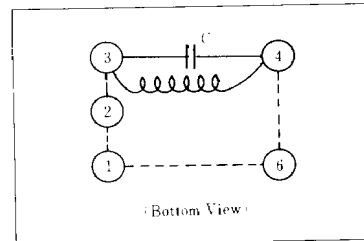

Number of: 14.5T  
Turns  
C: 100pF  
Qu: 60 typ

L2 (AM IFT Coil) Mitsumi No.MB-90439

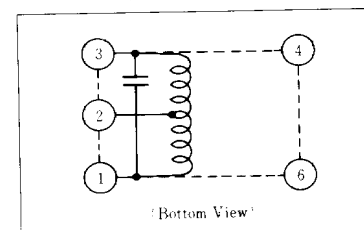

Number of: ①-②: 52T  
Turns ②-③: 94T  
C: 180pF  
Qu: 125 typ

■ PC-BOARD LAYOUT PATTERN

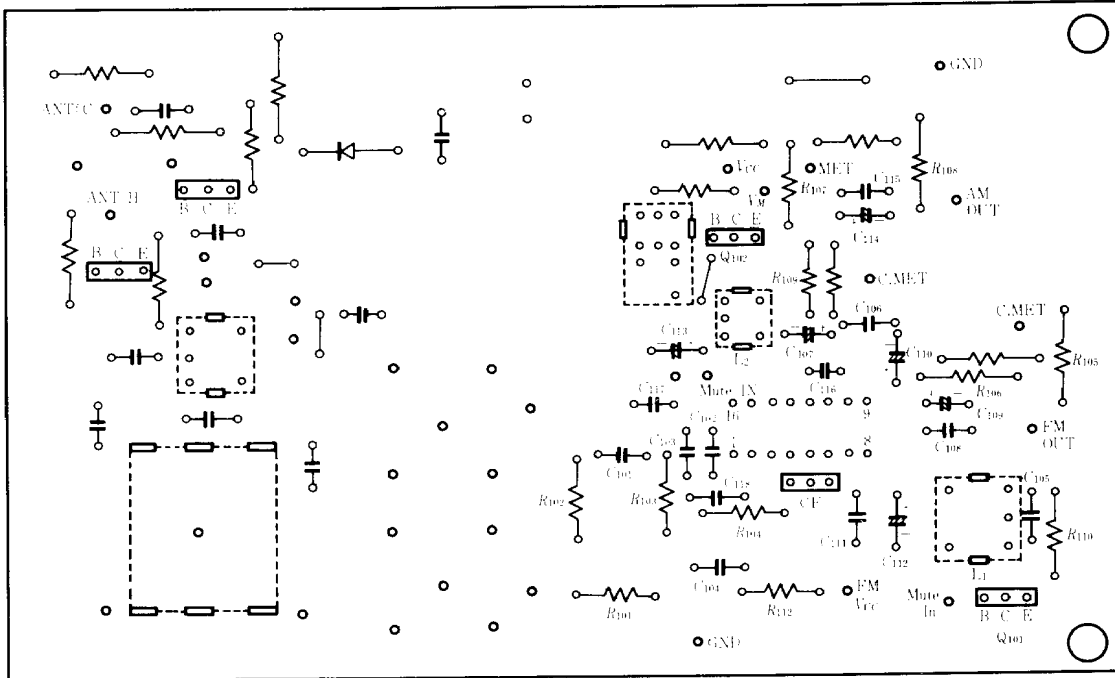

(Top View)

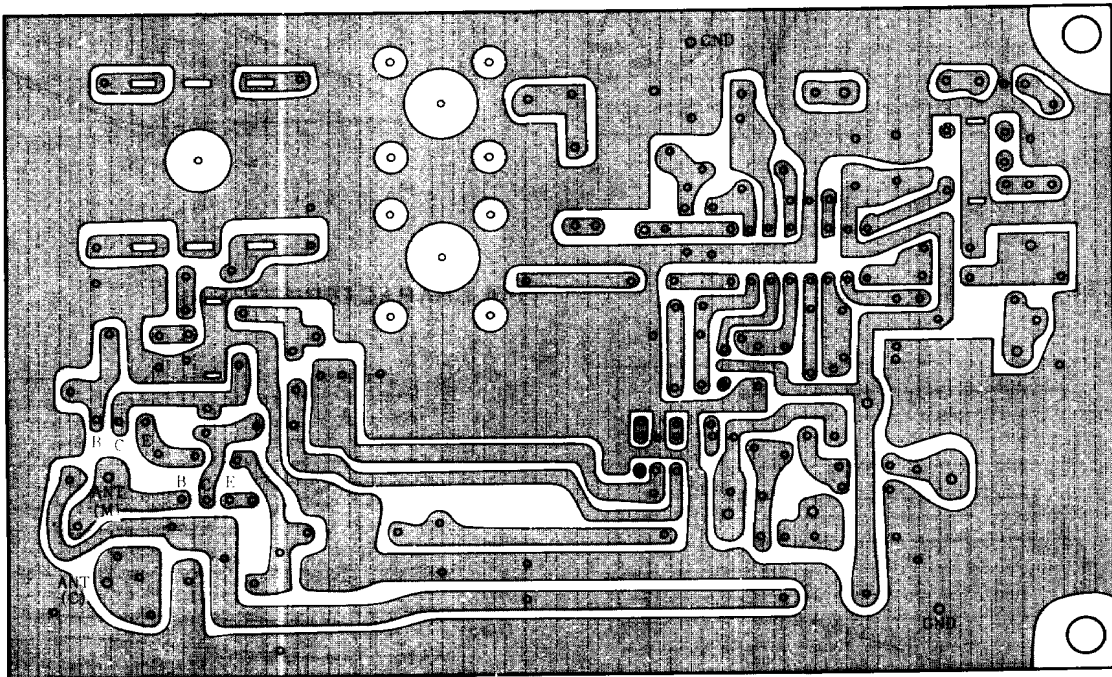

(Bottom View)

FM CHARACTERISTICS (1)

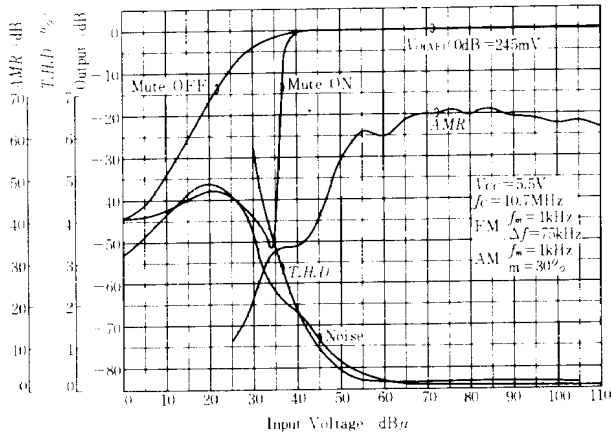

FM CHARACTERISTICS (2)

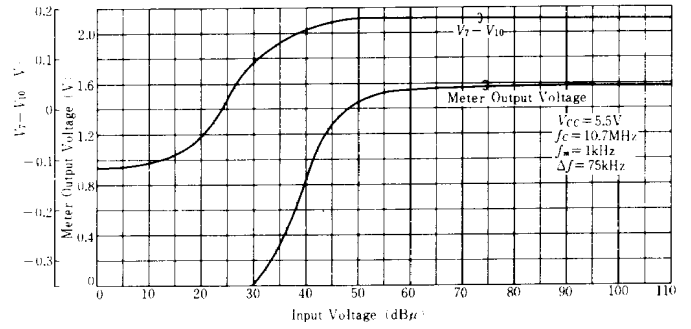

FM CHARACTERISTICS (3)

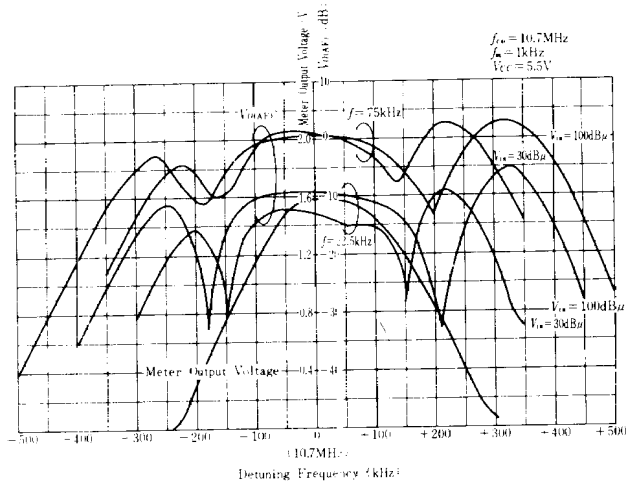

FM CHARACTERISTICS (4)

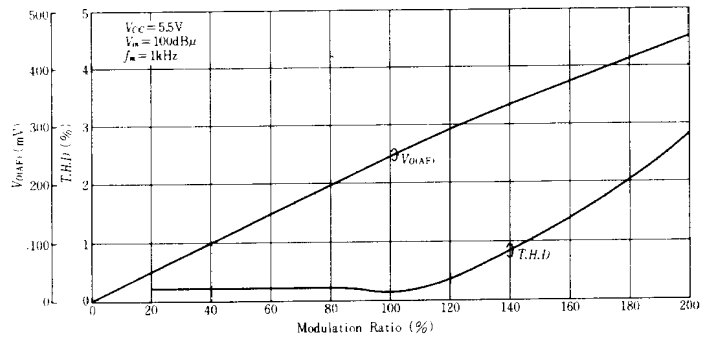

FM CHARACTERISTICS (5)

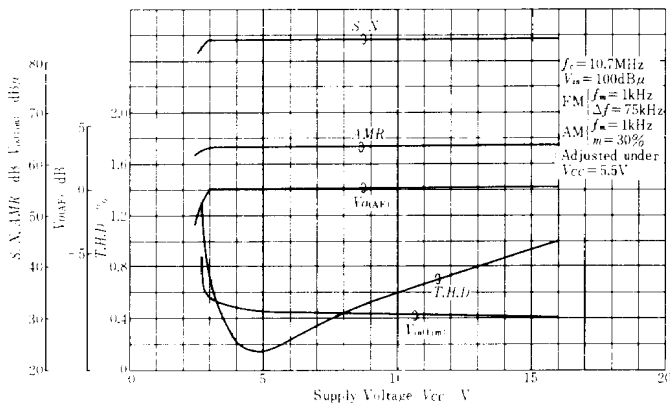

FM CHARACTERISTICS (6)

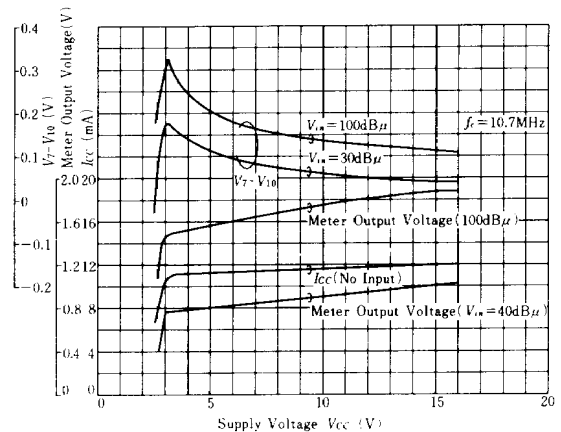

FM CHARACTERISTICS (7)

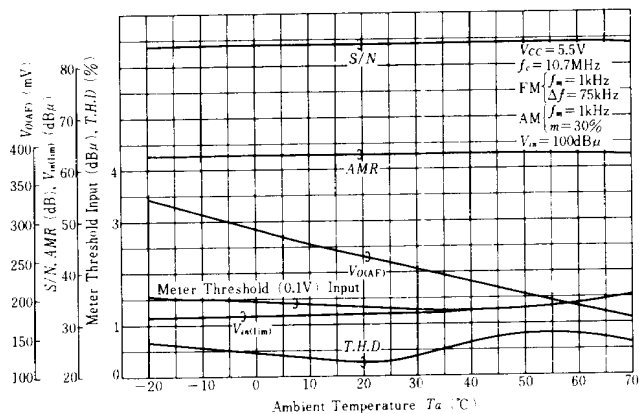

FM CHARACTERISTICS (8)

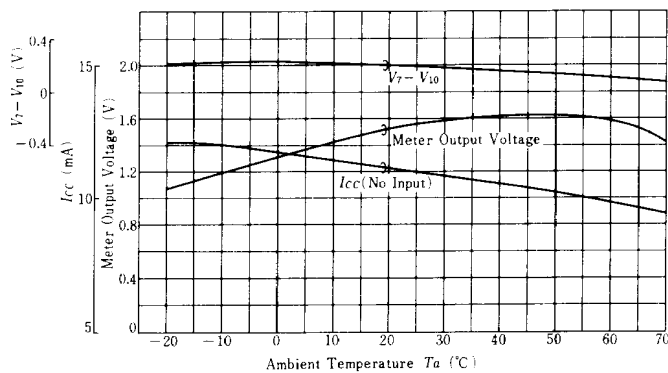

AM CHARACTERISTICS (1)

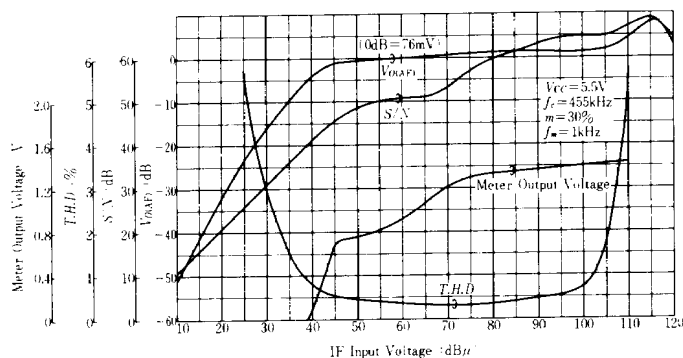

AM CHARACTERISTICS (2)

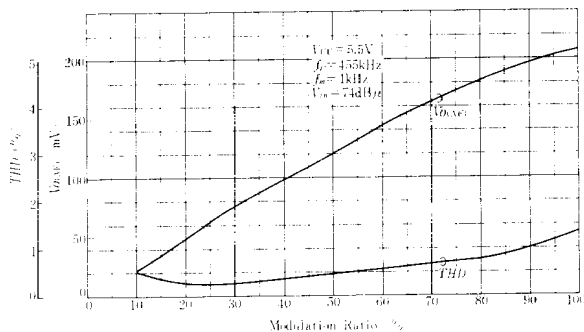

AM CHARACTERISTICS (3)

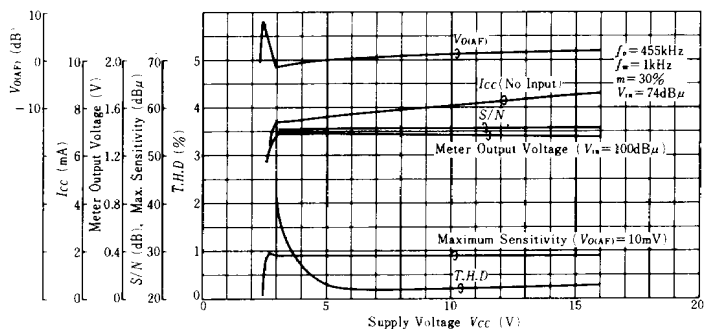

AM CHARACTERISTICS (4)

