

**2N6303**

**Silicon PNP Power Transistors**

**APPLICATIONS:**

- High-Speed Switching
- Medium-Current Switching
- High-Frequency Amplifiers

**FEATURES:**

- Collector-Emitter Sustaining Voltage:  $V_{CEO(sus)} = - 80 \text{ Vdc (Min)}$
- DC Current Gain:  $h_{FE} = 30-150 @ I_C = 1.5 \text{ Adc}$
- Low Collector-Emitter Saturation Voltage:  
 $V_{CE(sat)} = - 0.75 \text{ Vdc @ } I_C = 1.5 \text{ Adc}$
- High Current-Gain - Bandwidth Product:  $f_T = 90 \text{ MHz (Typ)}$

**DESCRIPTION:**

These power transistors are produced by PPC's DOUBLE DIFFUSED PLANAR process. This technology produces high voltage devices with excellent switching speeds, frequency response, gain linearity, saturation voltages, high current gain, and safe operating areas. They are intended for use in Commercial, Industrial, and Military power switching, amplifier, and regulator applications.

Ultrasonically bonded leads and controlled die mount techniques are utilized to further increase the SOA capability and inherent reliability of these devices. The temperature range to 200°C permits reliable operation in high ambients, and the hermetically sealed package insures maximum reliability and long life.

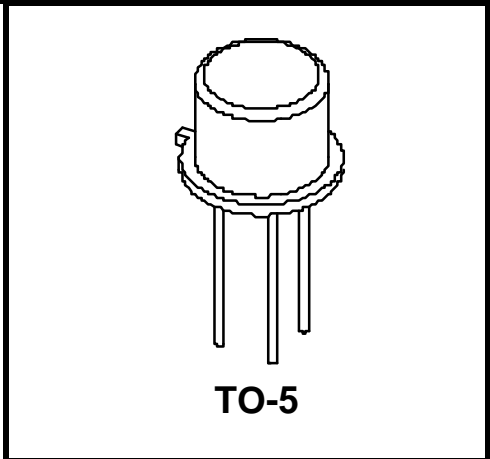

**ABSOLUTE MAXIMUM RATINGS:**

SYMBOL	CHARACTERISTIC	VALUE	UNITS
$V_{CEO}^*$	Collector-Emitter Voltage	- 80	Vdc
$V_{CB}^*$	Collector-Base Voltage	- 80	Vdc
$V_{EB}^*$	Emitter-Base Voltage	- 4.0	Vdc
$I_C^*$	Peak Collector Current	10	Adc
$I_C^*$	Continuous Collector Current	3.0	Adc
$I_B^*$	Base Current	0.5	Adc
$T_{STG}^*$	Storage Temperature	-65 to 200	°C
$T_J^*$	Operating Junction Temperature	-65 to 200	°C
$P_D^*$	Total Device Dissipation $T_C = 25^\circ\text{C}$ Derate above 25°C	6.0 34.3	Watts mW/°C
$P_D^*$	Total Device Dissipation $T_A = 25^\circ\text{C}$ Derate above 25°C	1.0 5.71	Watts mW/°C
$\theta_{JC}$	Thermal Resistance Junction to Case	29	°C/W
	Junction to Ambient	175	°C/W

\* Indicates JEDEC registered data.

**ELECTRICAL CHARACTERISTICS:  
 (25°C Case Temperature Unless Otherwise Noted)**

SYMBOL	CHARACTERISTIC	TEST CONDITIONS	VALUE		Units
			Min.	Max.	
$V_{CE(sus)}^*$	Collector-Emitter Sustaining Voltage	$I_C = 20 \text{ mAdc}, I_B = 0$ (Note 1)	- 80	----	Vdc
$BV_{CBO}^*$	Collector-Base Breakdown Voltage	$I_C = 100 \text{ } \mu\text{Adc}, I_E = 0$	- 80	----	Vdc
$BV_{EBO}^*$	Emitter-Base Breakdown Voltage	$I_E = 100 \text{ } \mu\text{Adc}, I_C = 0$	- 4.0	----	Vdc
$I_{CEX}^*$	Collector Cutoff Current	$V_{CE} = - 80V, V_{BE(off)} = 2.0 \text{ Vdc}$	----	1.0	$\mu\text{Adc}$
$I_{CBO}^*$	Collector Cutoff Current	$V_{CB} = - 80V, I_E = 0, T_C = 150^\circ\text{C}$	----	150	$\mu\text{Adc}$
$h_{FE}^*$	DC Current Gain (Note 1)	$I_C = 500 \text{ mAdc}, V_{CE} = - 1.0 \text{ Vdc}$ $I_C = 1.5 \text{ Adc}, V_{CE} = - 2.0 \text{ Vdc}$ $I_C = 2.5 \text{ Adc}, V_{CE} = - 3.0 \text{ Vdc}$ $I_C = 3.0 \text{ Adc}, V_{CE} = - 5.0 \text{ Vdc}$	35 30 20 20	---- 150 ---- ----	---- ---- ---- ----
$V_{CE(sat)}^*$	Collector-Emitter Saturation Voltage (Note 1)	$I_C = 500 \text{ mAdc}, I_B = 50 \text{ mAdc}$ $I_C = 1.5 \text{ Adc}, I_B = 150 \text{ mAdc}$ $I_C = 2.5 \text{ Adc}, I_B = 250 \text{ mAdc}$	---- ---- ----	- 0.5 - 0.75 - 1.3	Vdc Vdc Vdc
$V_{BE(sat)}^*$	Base-Emitter Saturation Voltage (Note 1)	$I_C = 500 \text{ mAdc}, I_B = 50 \text{ mAdc}$ $I_C = 1.5 \text{ Adc}, I_B = 150 \text{ mAdc}$ $I_C = 2.5 \text{ Adc}, I_B = 250 \text{ mAdc}$	---- - 0.9 ----	- 1.0 - 1.4 - 2.0	Vdc Vdc Vdc
$f_T^*$	Current Gain Bandwidth Product (Note 2)	$I_C = 100 \text{ mAdc}, V_{CE} = - 5.0 \text{ Vdc}, f_{test} = 20 \text{ MHz}$	60	----	MHz
$C_{ob}^*$	Output Capacitance	$V_{CB} = - 10 \text{ Vdc}, I_E = 0, f = 0.1 \text{ MHz}$	----	120	pF
$C_{ib}^*$	Input Capacitance	$V_{EB} = - 3.0 \text{ Vdc}, I_C = 0, f = 0.1 \text{ MHz}$	----	1000	pF
$t_d^*$	Delay Time	$V_{CC} = - 30 \text{ Vdc}, V_{BE(off)} = 0, I_C = 1.5 \text{ Adc}, I_{B1} = 150 \text{ mAdc}$	----	35	ns
$t_r^*$	Rise Time	$V_{CC} = - 30 \text{ Vdc}, V_{BE(off)} = 0, I_C = 1.5 \text{ Adc}, I_{B1} = 150 \text{ mAdc}$	----	65	ns
$t_s^*$	Storage Time	$V_{CC} = - 30 \text{ Vdc}, I_C = 1.5 \text{ Adc}, I_{B1} = I_{B2} = 150 \text{ mAdc}$	----	325	ns
$t_f^*$	Fall Time	$V_{CC} = - 30 \text{ Vdc}, I_C = 1.5 \text{ Adc}, I_{B1} = I_{B2} = 150 \text{ mAdc}$	----	75	ns

Note 1: Pulse Test: Pulse Width  $\leq 300\mu\text{s}$ , Duty Cycle  $\leq 2.0\%$ .

Note 2:  $f_T = |h_{fe}| * f_{test}$

\* Indicates JEDEC registered data.

**PACKAGE MECHANICAL DATA:**

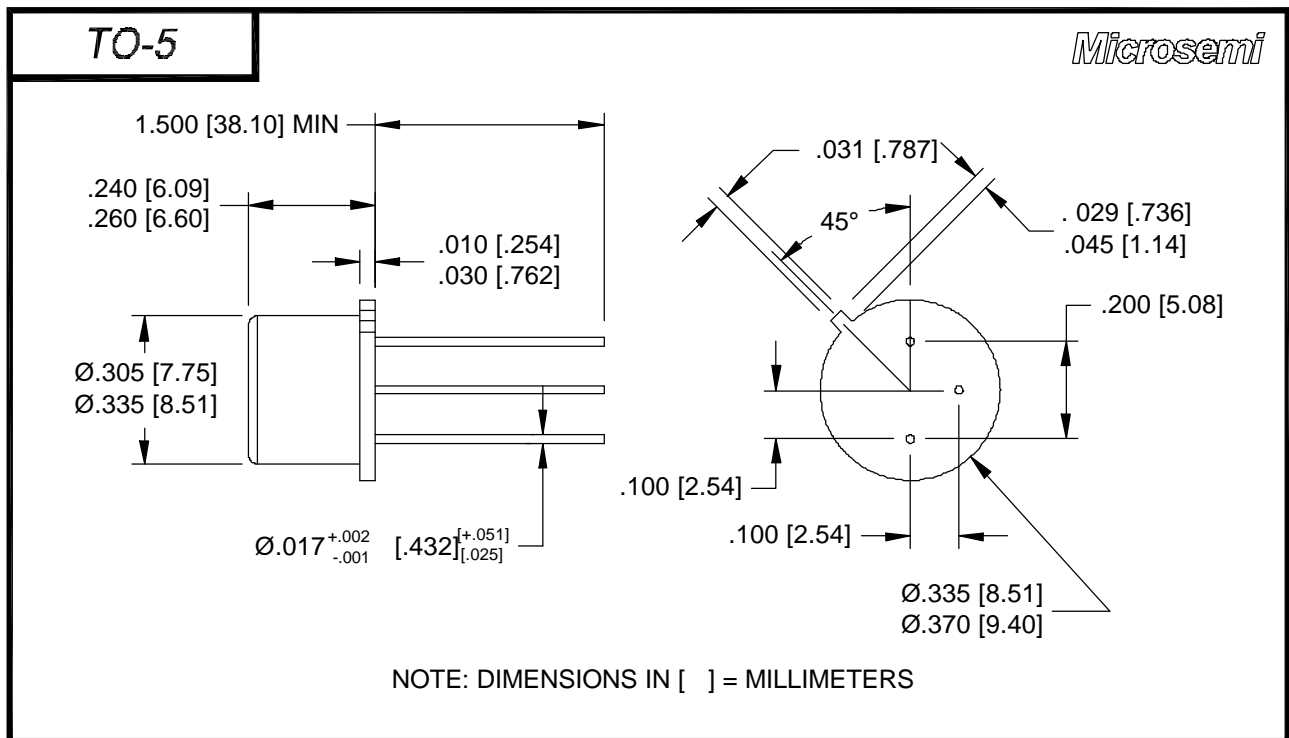



LittleDiode supplies new, hard to find or obsolete electronic components and semiconductors all over the world.

With over two million different components listed you are sure to find the part you need.

Feel free to visit us today at our online store:

[LittleDiode.com](http://LittleDiode.com)

Looking forward to providing you with the best possible service.