

2N5911 / 2N5912

FEATURES

- Tight Tracking
- Low Insertion Loss
- Good Matching

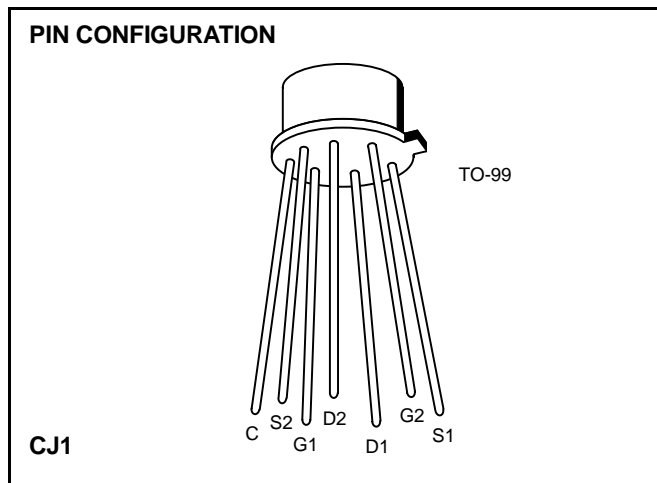

ABSOLUTE MAXIMUM RATINGS

(T_A = 25°C unless otherwise specified)

Gate-Drain or Gate-Source Voltage -25V
 Gate Current 50mA
 Storage Temperature Range -65°C to +200°C
 Operating Temperature Range -55°C to +150°C
 Lead Temperature (Soldering, 10sec) +300°C

	One Side	Both Sides
Power Dissipation	367mW	500mW
Derate above 25°C	3.0mW/°C	4.0mW/°C

NOTE: Stresses above those listed under "Absolute Maximum Ratings" may cause permanent damage to the device. These are stress ratings only and functional operation of the device at these or any other conditions above those indicated in the operational sections of the specifications is not implied. Exposure to absolute maximum rating conditions for extended periods may affect device reliability.

ORDERING INFORMATION

Part	Package	Temperature Range
2N5911-12	Hermetic TO-99	-55°C to +150°C
X2N5912	Sorted Chips in Carriers	-55°C to +150°C

ELECTRICAL CHARACTERISTICS (T_A = 25°C unless otherwise specified)

SYMBOL	PARAMETER	MIN	MAX	UNITS	TEST CONDITIONS	
I _{GSS}	Gate Reverse Current		-100	pA	V _{GS} = -15V, V _{DS} = 0 T _A = 150°C	
			-250	nA		
BV _{GSS}	Gate Reverse Breakdown Voltage	-25		V	I _G = -1μA, V _{DS} = 0	
V _{GS(off)}	Gate-Source Cutoff Voltage	-1	-5	V	V _{DS} = 10V, I _D = 1nA	
V _{GS}	Gate-Source Voltage	-0.3	-4	V	V _{DS} = 10V, I _D = 5mA	
I _G	Gate Operating Current		-100	pA	T _A = 150°C	
			-100	nA		
I _{DSS}	Saturation Drain Current (Pulsewidth 300μs, duty cycle ≤3%)	7	40	mA	V _{DS} = 10V, V _{GS} = 0V	
g _{fs}	Common-Source Forward Transconductance	5000	10,000	μS	V _{DS} = 10V, I _D = 5mA	
g _{fs}	Common-Source Forward Transconductance (Note 1)	5000	10,000			f = 1kHz
g _{os}	Common-Source Output Conductance		100			f = 100MHz
g _{oss}	Common-Source Output Conductance (Note 1)		150			f = 1kHz
C _{iss}	Common-Source Input Capacitance (Note 1)		5	pF	f = 100MHz	
C _{rss}	Common-Source Reverse Transfer Capacitance (Note 1)		1.2		f = 1MHz	
\bar{e}_n	Equivalent Short Circuit Input Noise Voltage (Note 1)		20	$\frac{nV}{\sqrt{Hz}}$	f = 10kHz	
NF	Spot Noise Figure (Note 1)		1	dB	f = 10kHz R _G = 100kΩ	

ELECTRICAL CHARACTERISTICS (Continued) ($T_A = 25^\circ\text{C}$ unless otherwise specified)

SYMBOL	PARAMETER	2N5911		2N5912		UNITS	TEST CONDITIONS	
		MIN	MAX	MIN	MAX			
$ I_{G1} - I_{G2} $	Differential Gate Current		20		20	nA	$V_{DG} = 10\text{V}$, $I_D = 5\text{mA}$	$T_A = 125^\circ\text{C}$
$\frac{I_{DSS1}}{I_{DSS2}}$	Saturation Drain Current Ratio	0.95	1	0.95	1		$V_{DS} = 10\text{V}$, $V_{GS} = 0$ (Pulsewidth $300\mu\text{A}$, duty cycle $\leq 3\%$)	
$ V_{GS1} - V_{GS2} $	Differential Gate-Source Voltage		10		15	mV	$V_{DG} = 10\text{V}$, $I_D = 5\text{mA}$	
$\frac{\Delta V_{GS1} - V_{GS2} }{\Delta T}$	Gate-Source Voltage Differential Drift (Measured at end points, T_A and T_B)		20		40	$\mu\text{V}/^\circ\text{C}$		$T_A = 25^\circ\text{C}$ $T_B = 125^\circ\text{C}$
			20		40			$T_A = -55^\circ\text{C}$ $T_B = 25^\circ\text{C}$
$\frac{g_{fs1}}{g_{fs2}}$	Transconductance Ratio	0.95	1	0.95	1			$f = 1\text{kHz}$

NOTE 1: For design reference only, not 100% tested.

This datasheet has been downloaded from:

www.DatasheetCatalog.com

Datasheets for electronic components.



LittleDiode supplies new, hard to find or obsolete electronic components and semiconductors all over the world.

With over two million different components listed you are sure to find the part you need.

Feel free to visit us today at our online store:

LittleDiode.com

Looking forward to providing you with the best possible service.