

LA7520N, 7521N



3061

Monolithic Linear IC's

[VIF+SIF] Circuits for TV Sets, VTR's

©17944

The LA7520N is an IC containing the VIF section and SIF section on a single chip in the DIP30S package (equivalent to the DIP22 heretofore in use) of shrink type. Since the LA7520N is capable of performing video detection and sound detection independently or simultaneously, it can be applied to various sets from popular type to high-grade type according to the designer's policy. As compared with the LA7520, the LA7520N is more improved in differential gain, noise canceler characteristic. The LA7520 and LA7520N are compatible with each other.

The LA7521N is an IC designed to meet diversified specifications for tuners and is different the LA7520N in maximum RF AGC voltage V_{13H} . Further, when a coil is used in the FM detector, the detection output voltage can be made high because the LA7521N has a high FM detector input impedance.

Functions

- VIF section: VIF amp, video detector, peak IF AGC, B/W noise canceler, RF AGC, AFT, SIF detector
- SIF section: SIF limiter amp, FM detector, DC attenuator, AF driver

Features

- High-gain VIF amp requiring no preamp
- High AGC speed
- Provides wide-band detection characteristic and meets sound MPX demodulation requirements because of FM detection being quadrature detection.
- Possible to use sound REC pin (pin 2), AUX pin (pin 3)
- Possible to mute video, sound for VTR:
 - Pin 7 GND: Muting of both video and sound
 - Pin 29 GND: Muting of sound only

Equivalent Circuit Block Diagram

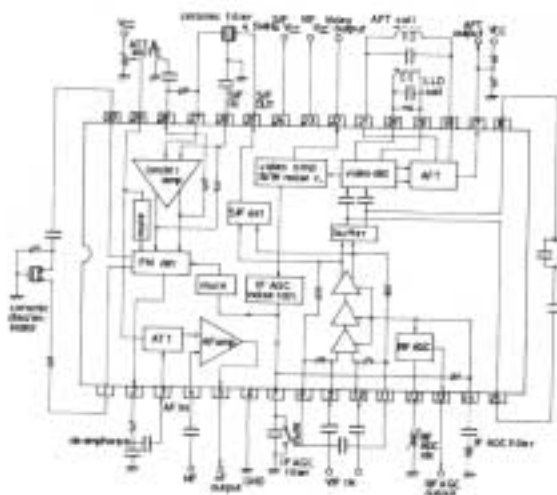

Case Outline 3061-D305NIC
(unit : mm)

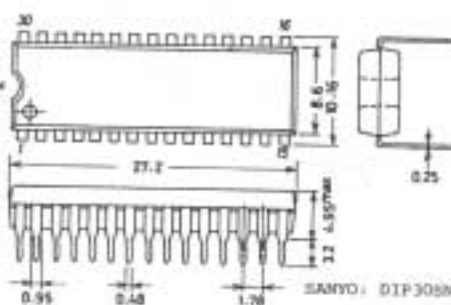

S315K1, T5 - No. 1794-1/3

LA7520N, 7521N

Operating Characteristics/ $T_B = 25^\circ\text{C}$, $V_{CC} = 12\text{V}$, $f_p = 58.75\text{MHz}$, $f_s = 54.25\text{MHz}$ (VIF), $f_o = 4.5\text{MHz}$ (SIF), *: mVrms [VIF Section]

			min	typ	max	unit
Total circuit current	I23 + I24	dc	59	74	98	mA
Maximum RF AGC voltage	V13H	dc	8.5	8.9	9.2	V
		dc	10.2	10.6	11.0	V
Minimum RF AGC voltage	V13L	dc		0	0.5	V
Quiescent video output voltage	V22	dc	5.6	6.1	6.6	V
Quiescent AFT output voltage	V17	dc	4.5	6.5	7.5	V
Input sensitivity	vi	fm = 400Hz - 40%AM, vo = 0.8vpp	30	36	42	dB μ
AGC voltage	GR	fm = 15kHz - 78%AM, vo = $\pm 1\text{dB}$	60	74		dB
Maximum allowable input voltage	vi max	fm = 15kHz - 78%AM, vo = $\pm 1\text{dB}$	100	500		mVrms
Video output amplitude	vo22	vi = 10° , fm = 15kHz - 78%AM	1.9	2.2	2.5	Vpp
Output S/N	S/N	vi = 10° , CW	48	54		dB
Carrier leak	CL	vi = 100° , fm = 15kHz - 78%AM	50	57		dB
Maximum AFT voltage	V17H	vi = 10° , SWEEP	11.0	11.5	12.0	V
Minimum AFT voltage	V17L	vi = 10° , SWEEP	0	0.4	1.0	V
AFT Detection sensitivity	sf	vi = 10° , SWEEP	70	100	140	mV/kHz
White noise threshold voltage	VWTH	vi = 10° , SWEEP	6.4	6.8	7.2	V
White noise clamp level	VWCL	vi = 10° , SWEEP	4.2	4.6	5.0	V
Black noise threshold voltage	VBTH	vi = 10° , SWEEP	2.1	2.4	2.7	V
Black noise clamp level	VBCL	vi = 10° , SWEEP	3.8	4.2	4.6	V
SI output signal voltage	Vo25	P/S = 20dB	40	60	100	mVrms
Frequency characteristic	fc	-3dB	6	8		MHz
Differential gain	DG	vi = 10° - 87.5%, video-mode		3	6	%
Differential phase	DP	vi = 10° - 87.5%, video-mode		3	6	deg
Input resistance	ri		1.0	1.5	2.0	k Ω
Input capacitance	ci			3.5	7.0	pF
[SIF Section]			min	typ	max	unit
SIF limiting sensitivity	ViLim	-3dB		200	400	μVrms
Detection output voltage	Vo2	vi = 100° , fm = 400Hz, $\Delta f = \pm 25\text{kHz}$	450	680	850	mVrms
Total harmonic distortion	THD	vi = 100° , fm = 400Hz, $\Delta f = \pm 25\text{kHz}$		0.5	1.0	%
AM rejection	AMR	vi = 100° , fm = 400Hz, $\Delta f = \pm 25\text{kHz}$, -30%AM	50	60		dB
DCVR maximum attenuation	ATT	vi = 200° , f = 400Hz	70	80		dB
AF amp gain	VGAF	vi = 100° , f = 400Hz	18	20	22	dB
AF amp output voltage	vo5	THD = 10%, f = 400Hz	3	4		Vrms

(Note)

- FM detector input impedance (pin 30)

	typ
LA7520N	2k Ω
LA7521N	4.9k Ω

Electronic volume control characteristic

