

# M5228P/FP

## QUAD LOW-NOISE OPERATIONAL AMPLIFIERS (DUAL POWER SUPPLY TYPE)

### DESCRIPTION

The M5228 is a semiconductor integrated circuit designed for a low-noise preamplifier in audio equipment and a general-purpose operational amplifier in other electronic equipment. Four low-noise operational amplifier circuits displaying internal phase-compensated high gain and low distortion are contained in a 14-pin standard DIP and 14-pin mini flat (FP) package for application over a wide range as a general-purpose dual amplifier in general electronic equipment.

The device has virtually the same characteristics as the 4557, 4558, 4559 and 741 operational amplifiers. The unit can also be used as a single power supply type and amplifier in portable equipment. It is also suitable as a headphone amplifier because of its high load current.

### FEATURES

- High gain, low distortion  
.....  $G_{VO}=110\text{dB}$ ,  $\text{THD}=0.0015\%$ (typ.)
- High slew rate, high  $f_T$  .....  $\text{SR}=2.2\text{V}/\mu\text{s}$ ,  $f_T=7\text{MHz}$ (typ.)
- Low noise ( $R_G=1\text{k}\Omega$ ) FLAT .....  $V_{NI}=2\mu\text{Vrms}$ (typ.)  
RIAA .....  $V_{NI}=1\mu\text{Vrms}$ (typ.)
- Operation with low supply voltage .....  $V_{CC}\geq 4\text{V}(\pm 2\text{V})$
- High load current, high power dissipation  
.....  $I_{LP}=\pm 50\text{mA}$ ,  $P_D=700\text{mW}$ (M5228P)  
 $P_D=550\text{mW}$ (M5228FP)

### APPLICATION

General-purpose amplifier in stereo equipment, tape decks and radio stereo cassette recorders; active filters, servo amplifiers, operational circuits in other general electronic equipment.

### RECOMMENDED OPERATING CONDITION

- Supply voltage range .....  $\pm 2\sim\pm 16\text{V}$
- Rated supply voltage .....  $\pm 15\text{V}$

### PIN CONFIGURATION (TOP VIEW)

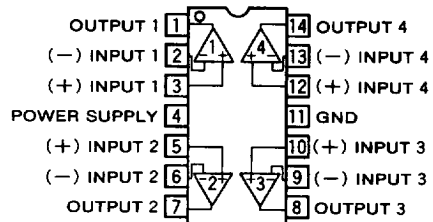

Outline 14P4 (P)  
14P2S-A (FP)

### BLOCK DIAGRAM

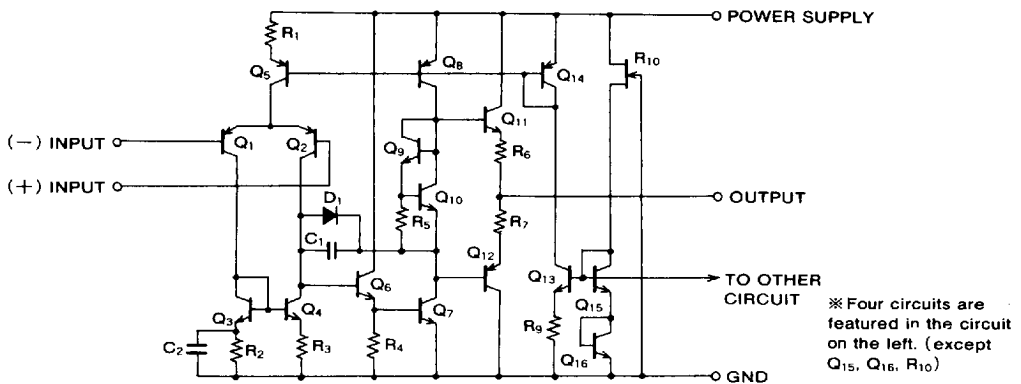

6249826 0021552 329



**QUAD LOW-NOISE OPERATIONAL AMPLIFIERS (DUAL POWER SUPPLY TYPE)**

**ABSOLUTE MAXIMUM RATINGS** ( $T_a=25^\circ\text{C}$ , unless otherwise noted)

Symbol	Parameter	Conditions	Ratings	Unit
$V_{CC}$	Supply voltage		$\pm 18$	V
$I_{LP}$	Load current		$\pm 50$	mA
$V_{ID}$	Differential input voltage		$\pm 30$	V
$V_{IC}$	Common input voltage		$\pm 15$	V
$P_d$	Power dissipation		700(DIP)/550(FP)	mW
$K_\theta$	Thermal derating	$T_a \geq 25^\circ\text{C}$	7(DIP)/5.5(FP)	mW/ $^\circ\text{C}$
$T_{opr}$	Ambient temperature		$-20 \sim +75$	$^\circ\text{C}$
$T_{stg}$	Storage temperature		$-55 \sim +125$	$^\circ\text{C}$

**ELECTRICAL CHARACTERISTICS** ( $T_a=25^\circ\text{C}$ ,  $V_{CC}=\pm 15\text{V}$ )

Symbol	Parameter	Test conditions	Limits			Unit
			Min.	Typ.	Max.	
$I_{CC}$	Circuit current	$V_{in}=0$		6.0	12.0	mA
$V_{IO}$	Input offset voltage	$R_s \leq 10\text{k}\Omega$		0.5	6.0	mV
$I_{IO}$	Input offset current			5	200	nA
$I_{IB}$	Input bias current				500	nA
$R_{in}$	Input resistance		0.3	5		M $\Omega$
$G_{VO}$	Open loop voltage gain	$R_L \geq 2\text{k}\Omega$ , $V_o = \pm 10\text{V}$	86	110		dB
$V_{OM}$	Maximum output voltage	$R_L \geq 10\text{k}\Omega$	$\pm 12$	$\pm 14$		V
		$R_L \geq 2\text{k}\Omega$	$\pm 10$	$\pm 13$		
$V_{CM}$	Common input voltage range		$\pm 12$	$\pm 14$		V
CMRR	Common mode rejection ratio	$R_s \leq 10\text{k}\Omega$	70	90		dB
SVRR	Supply voltage rejection ratio	$R_s \leq 10\text{k}\Omega$		30	150	$\mu\text{V}/\text{V}$
$P_d$	Power dissipation			180	360	mW
SR	Slew rate	$G_v=0\text{dB}$ , $R_L=2\text{k}\Omega$		2.2		V/ $\mu\text{s}$
$f_T$	Gain bandwidth product			7		MHz
$V_{NI}$	Input referred noise voltage	$R_s=1\text{k}\Omega$ , BW:10Hz $\sim$ 30kHz		2.0		$\mu\text{Vrms}$

**TYPICAL CHARACTERISTICS**

**THERMAL DERATING (MAXIMUM RATING)**

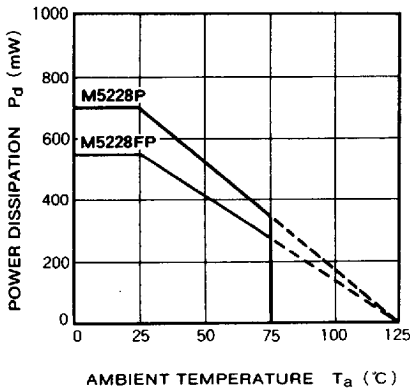

**VOLTAGE GAIN VS. FREQUENCY RESPONSE**

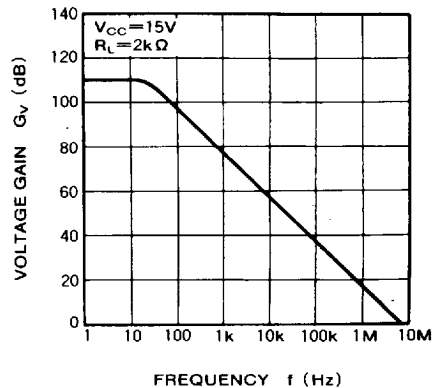

6249826 0021553 265



**QUAD LOW-NOISE OPERATIONAL AMPLIFIERS (DUAL POWER SUPPLY TYPE)**

**CIRCUIT CURRENT VS. SUPPLY VOLTAGE**

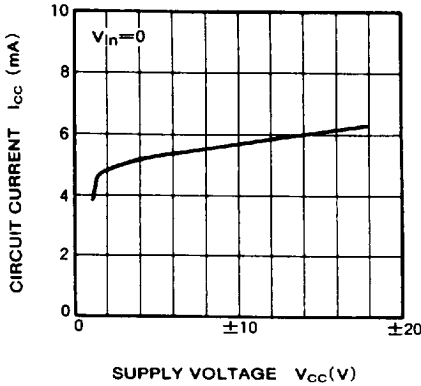

**CIRCUIT CURRENT VS. AMBIENT TEMPERATURE**

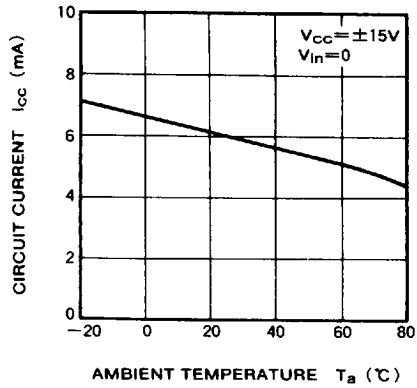

**INPUT OFFSET VOLTAGE VS. AMBIENT TEMPERATURE**

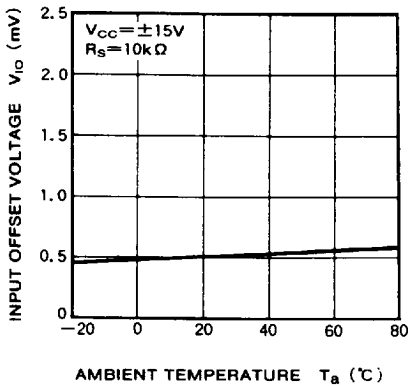

**OUTPUT VOLTAGE / LOAD CURRENT PEAK VS. LOAD RESISTANCE**

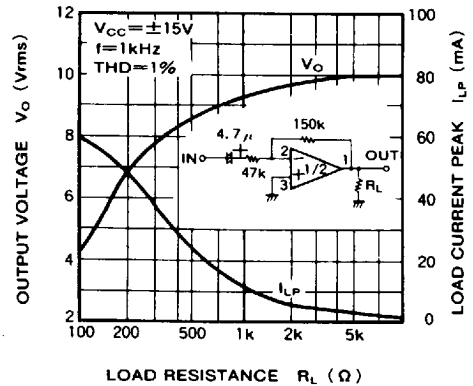

**MAXIMUM OUTPUT VOLTAGE VS. SUPPLY VOLTAGE**

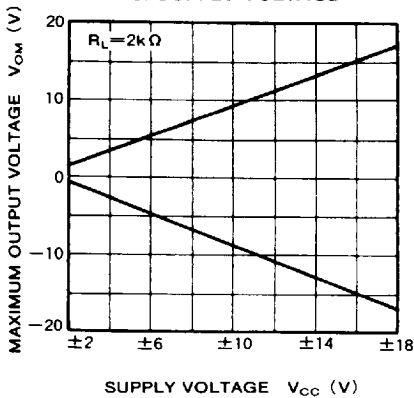

**MAXIMUM OUTPUT VOLTAGE VS. FREQUENCY RESPONSE**

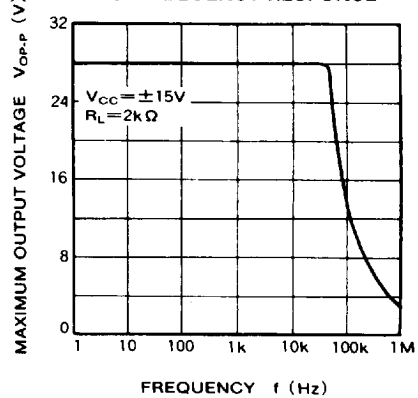

■ 6249826 0021554 1T1 ■

