

62E D ■ 6249826 0015095 970 ■ MIT2

MITSUBISHI ELEK (LINEAR)

MITSUBISHI LINEAR ICs

M51131L

2 CHANNEL ELECTRONIC VOLUME BALANCE

DESCRIPTION

The M51131L is a semiconductor integrated circuit designed for dual-channel electronic volume balance control.

It is housed in a 14-pin plastic molded zig-zag line package and left/right independent volume control or left/right simultaneous volume control plus balance control can be selected by the DC voltages.

Built-in pass through function enables automatic level control in combination with the ALC amplifier circuit.

FEATURES

- Two control modes can be selected.
(Left/right independent volume control mode or left/right simultaneous volume + balance control mode)
- Pass through switch is included to output the input signal as it is, irrespective of the volume/balance control voltages.
- Shock noise reduction pin is included to reduce pass through switch on/off shock noise.
- Built-in reference supply voltage circuit
..... output current 10mA (typ.)
- Maximum permissible input
..... 3.4Vrms (typ.) (f=1kHz, THD=1%)
- High attenuation
..... 105dB (typ.) (f=1kHz, Vi=2Vrms, JIS-A)
- Low distortion rate
0.005% (typ.) (f=1kHz, Vi=500mVrms, 15kHz LPF)
- Good channel separation
..... 102dB (typ.) (f=1kHz, Vo=2Vrms, JIS-A)

APPLICATION

High-fidelity VTR, Television set, Radio cassette player, Car stereo set, High-fidelity amplifier, Cassette deck player

RECOMMENDED OPERATING CONDITIONS

- Rated supply voltage range 8~15V
- Rated supply voltage 12V

PIN CONFIGURATION (TOP VIEW)

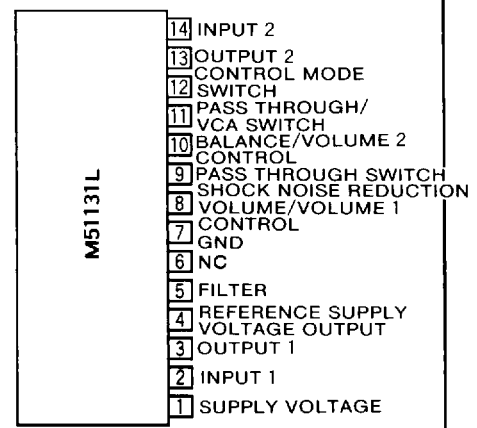

NC : NO CONNECTION

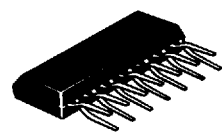

14-pin plastic molded ZIP

BLOCK DIAGRAM

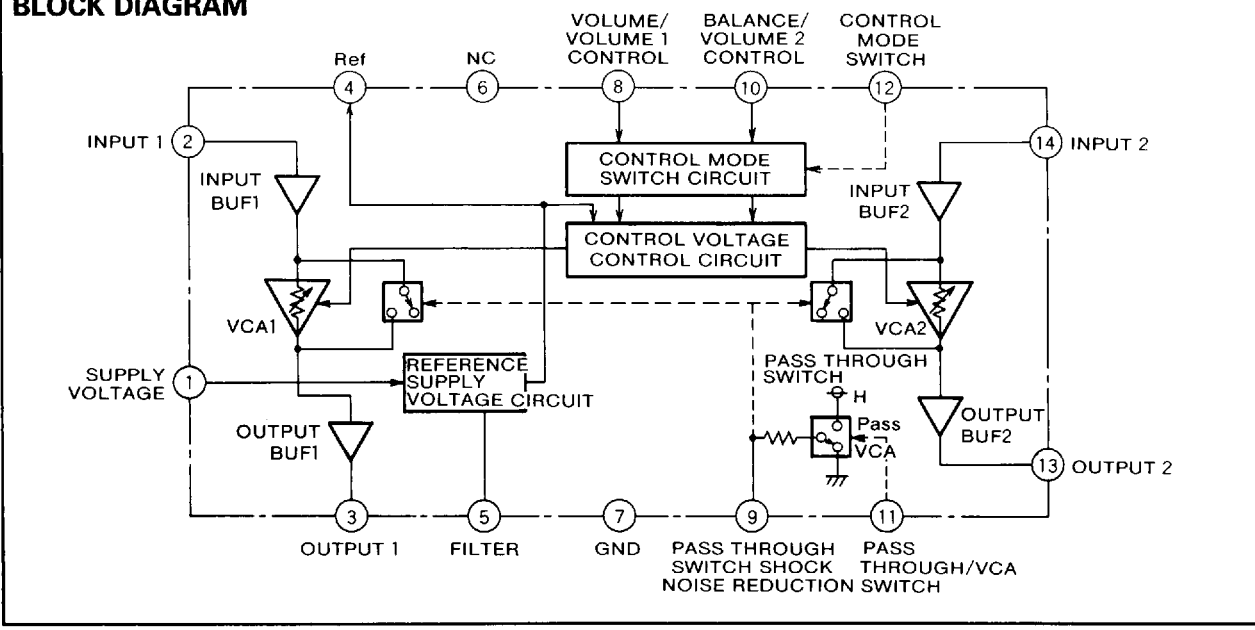

2 CHANNEL ELECTRONIC VOLUME BALANCE

PIN ASSIGNMENT

Pin No.	Name	Operation	Typical DC voltage
①	Power supply	DC 8~15V is applied (rated voltage 12V)	
②	Input 1	Maximum permissible input 3.4Vrms (typ.)	5.5V
③	Output 1		4.8V
④	Reference supply voltage output	Maximum output current 10mA (typ.), built-in short circuit protection circuit	5.2V
⑤	Filter		12V
⑥	No connection	Can be used for wire repeater to GND, etc.	
⑦	GND		
⑧	Volume/volume 1 control	Left/right simultaneous volume or channel 1 volume is controlled by this value in the range of 0 to 5.2V DC.	
⑨	Pass through switch shock noise reduction	Transit noise to the ear is softened by slowly switching between pass through and VCA with time constant when the pass through switch is turned on/off. The time constant is determined by externally connected capacitor. $T(\text{Sec})=1.2 \times C \times 20k$	5.2V for pass through and 0V for VCA
⑩	Balance/volume 2 control	Balance or channel 2 volume is controlled with 0 to 5.2V.	
⑪	Pass through/VCA switch	Operates as VCA with 0V, and passes through the input to output with 5.2V.	
⑫	Control mode switch	Operates as channel 1 volume at pin ⑧ and as channel 2 volume at pin ⑩ with 0V. Operates as channel 1 and channel 2 simultaneous volume at pin ⑧ and as balance at pin ⑩ with 5.2V.	
⑬	Output 2		4.8V
⑭	Input 2	Maximum permissible input 3.4Vrms (typ)	5.5V

ABSOLUTE MAXIMUM RATINGS ($T_a=25^\circ\text{C}$, unless otherwise noted)

Symbol	Parameter	Conditions	Ratings	Unit
V_{CC}	Supply voltage		15.5	V
I_{CC}	Circuit current		40	mA
P_d	Power dissipation	When mounted on PC board	800	mW
K_θ	Thermal derating	$T_a \geq 25^\circ\text{C}$	8.0	mW/°C
T_{opr}	Operating temperature		-20~+75	°C
T_{stg}	Storage temperature		-40~+125	°C

TYPICAL CHARACTERISTICS

THERMAL DERATING (MAXIMUM RATING)

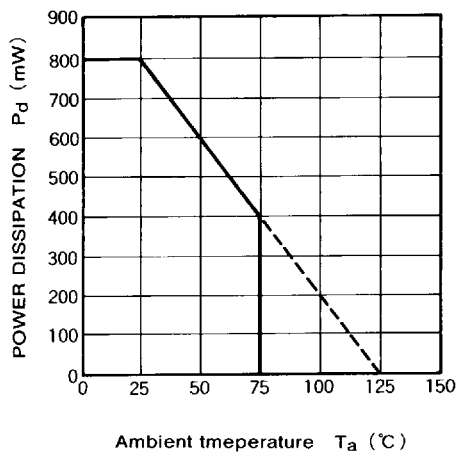

CIRCUIT CURRENT VS. SUPPLY VOLTAGE

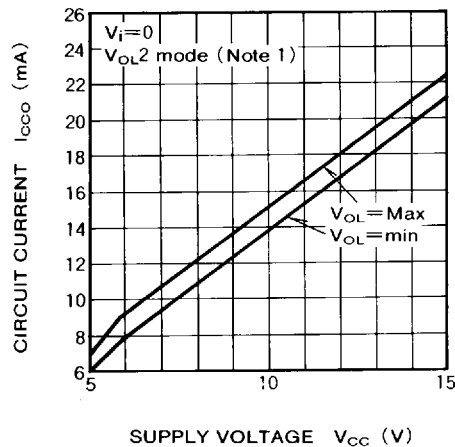

Note 1. V_{OL2} mode means left/right independent volume control mode.

MITSUBISHI ELEK (LINEAR)

2 CHANNEL ELECTRONIC VOLUME BALANCE

ATTENUATION VS. VOLUME CONTROL

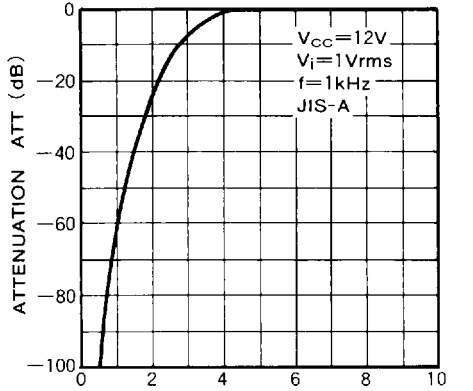

VOLUME CONTROL VOLTAGE V_{VOL} (V)

ATTENUATION VS. BALANCE CONTROL VOLTAGE

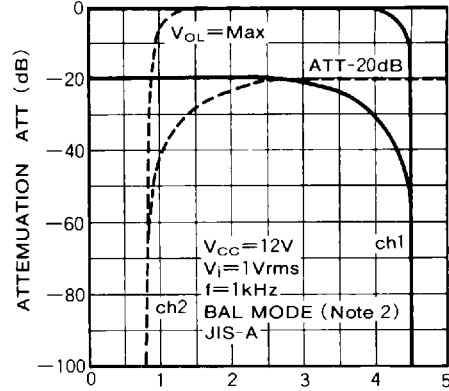

BALANCE CONTROL V_{BAL} (L)

Note 2. BAL mode means left/right simultaneous volume and balance control mode.

TOTAL HARMONIC DISTORTION VS. OUTPUT VOLTAGE

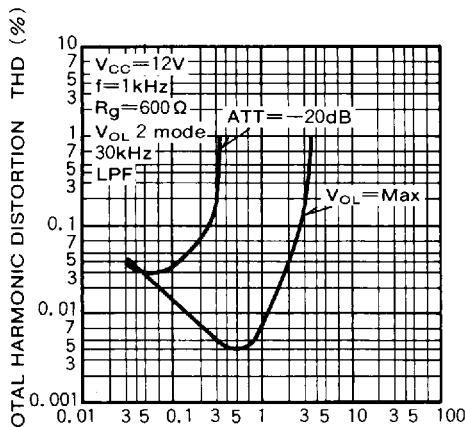

OUTPUT VOLTAGE V_O (Vrms)

OUTPUT NOISE VOLTAGE VS. ATTENUATION

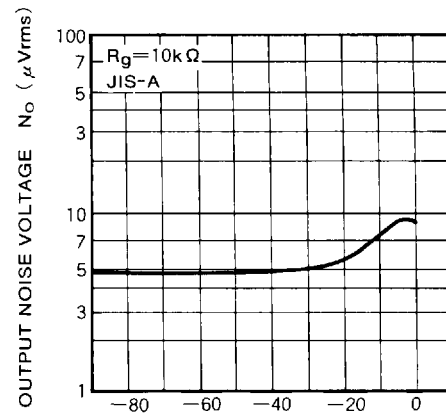

ATTENUATION ATT (dB)

ATTENUATION VS. FREQUENCY CHARACTERISTICS

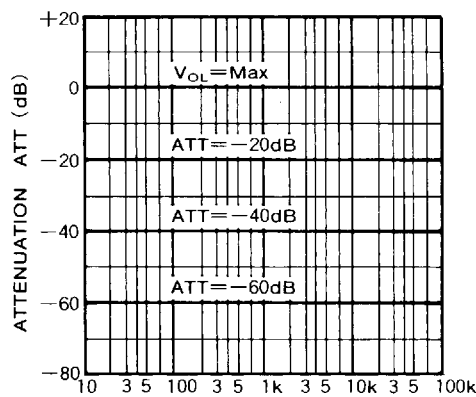

FREQUENCY f (Hz)

CROSSTALK VS. FREQUENCY CHARACTERISTICS

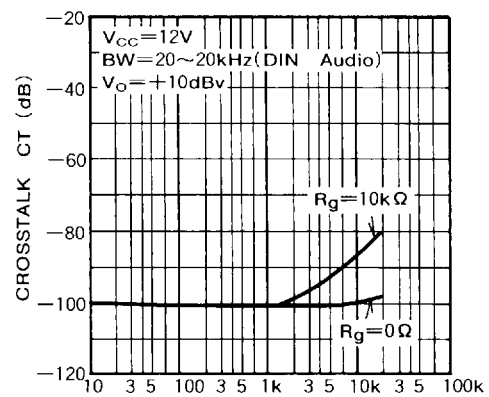

FREQUENCY f (Hz)

2 CHANNEL ELECTRONIC VOLUME BALANCE

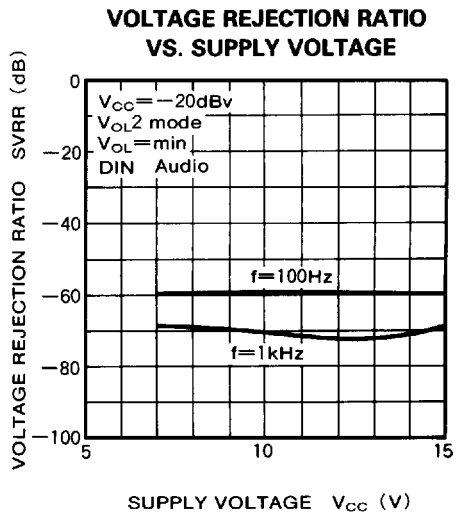
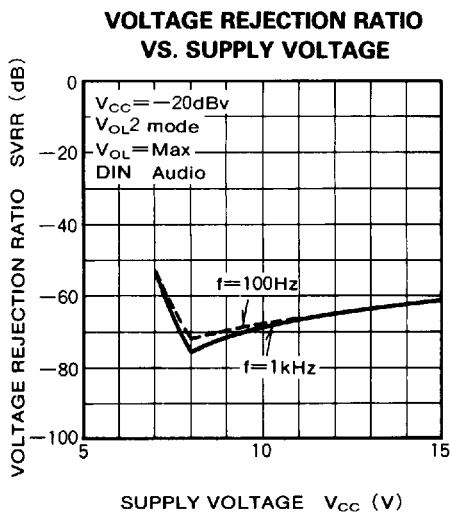
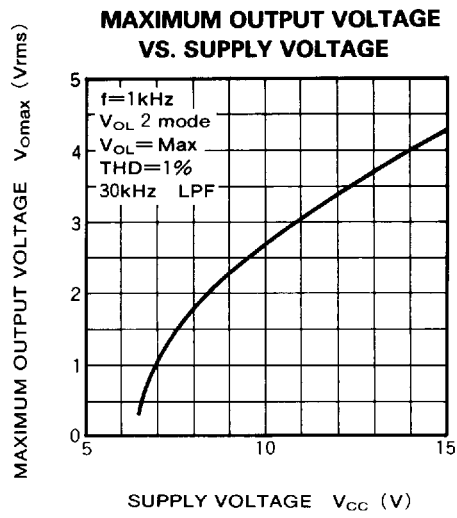
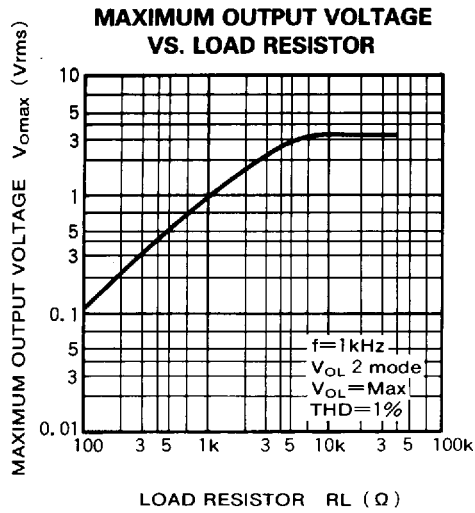

MITSUBISHI ELEK (LINEAR)

2 CHANNEL ELECTRONIC VOLUME BALANCE

ELECTRICAL CHARACTERISTICS ($T_a=25^{\circ}\text{C}$, $V_{CC}=12\text{V}$, $f=1\text{kHz}$, $V_i=1\text{Vrms}$, Volume Max, unless otherwise noted)

Symbol	Parameter	Test conditions	Limits			Unit
			Min	Typ	Max	
I_{CCO}	Circuit current	In quiescent state, volume: min		17		mA
ATT_O	Attenuation			0		dB
Att_{∞}		$V_i=2\text{Vrms}$, JIS-A, volume: min		-105		dB
CB	Channel balance			0		dB
THD	Total harmonic distortion	15kHz, LPF		0.01		%
R_i	Input resistor			150		k Ω
BAL	Balance attenuation	$V_i=2\text{Vrms}$, JIS-A		-105		dB
N_{Omin}	Output noise voltage	$R_g=10\text{k}\Omega$ in quiescent state, JIS-A, volume: min		4.8		μVrms
N_{Omax}		$R_g=10\text{k}\Omega$ in quiescent state, JIS-A		9		μVrms
V_{imax}	Maximum input voltage	THD=1%, volume: Center		3.4		Vrms
V_{Omax}	Maximum output voltage	THD=1%		3.4		Vrms
C_T	Crosstalk	$R_g=0\Omega$, $V_i=2\text{Vrms}$, JIS-A		-102		dB
G_{VP}	Pass through voltage gain	Volume: min		+0.8		dB
C_{BP}	Pass through channel balance	Volume: min		0		dB

Note 3. The volume Max means the condition in which the same voltage as V_i is applied to pin ⑧.

4. The volume Center means the condition in which the same voltage as $V_i/2$ is applied to pin ⑧.

5. The volume min means the condition in which pin ⑧ is connected to GND.

I/O TYPE

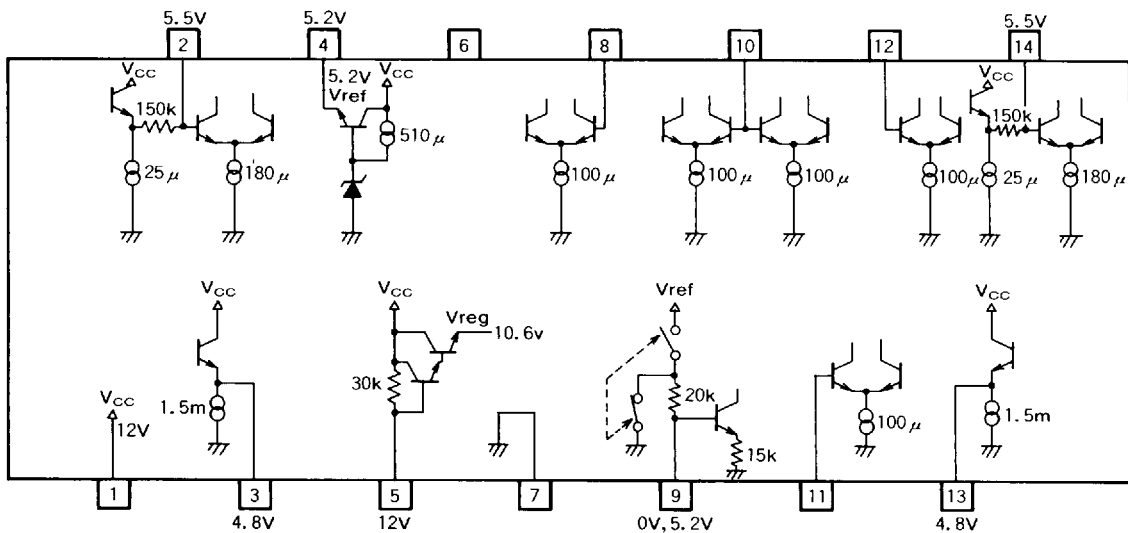

Note 6. All resistors, voltages, currents are shown in typical values.

Unit Resistance : Ω

Voltage : V

Current : A

MITSUBISHI ELEK (LINEAR)

2 CHANNEL ELECTRONIC VOLUME BALANCE

TEST CIRCUIT

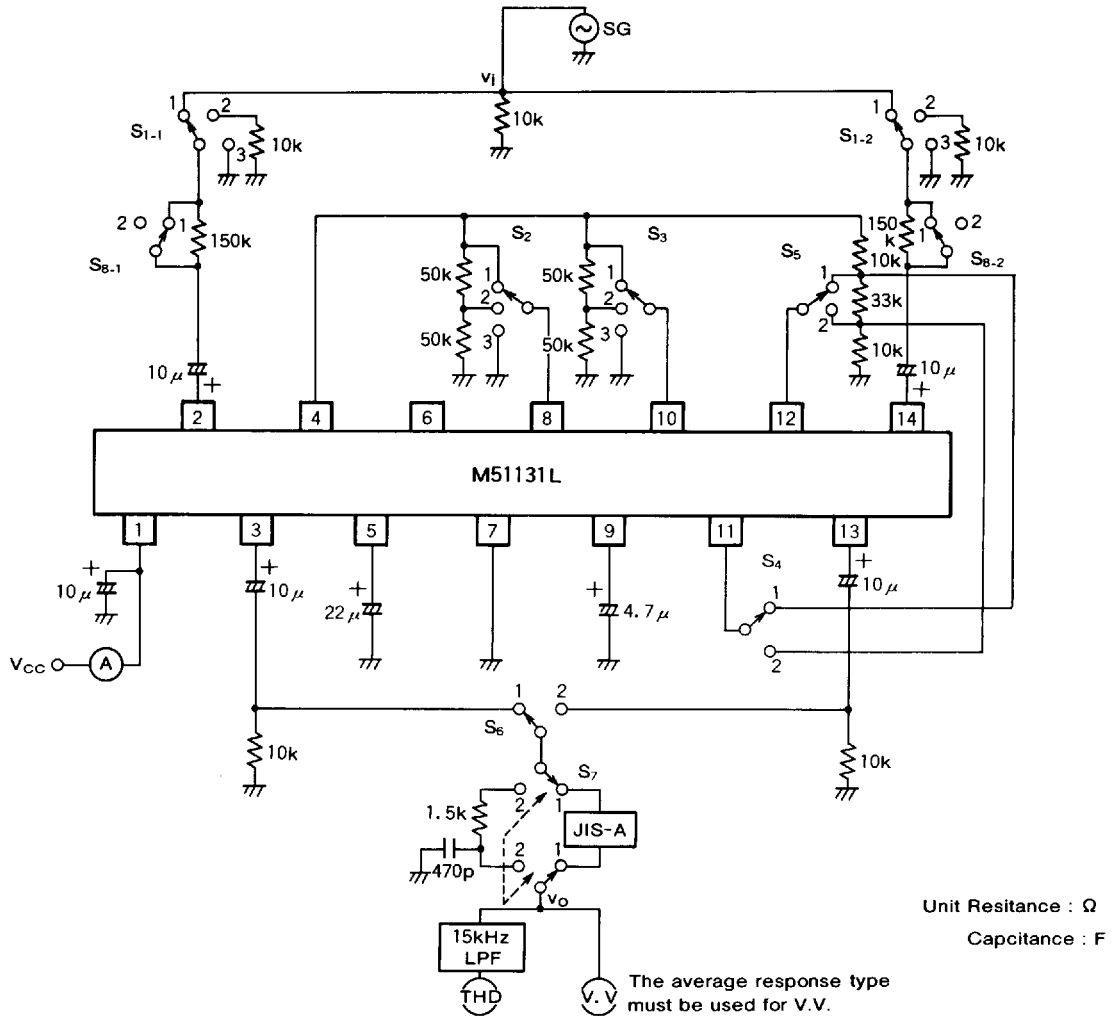

The JIS-A filter can be replaced with the following circuit.

Example of JIS-A filter equivalent circuit (Note that the output is multiplied by 100).

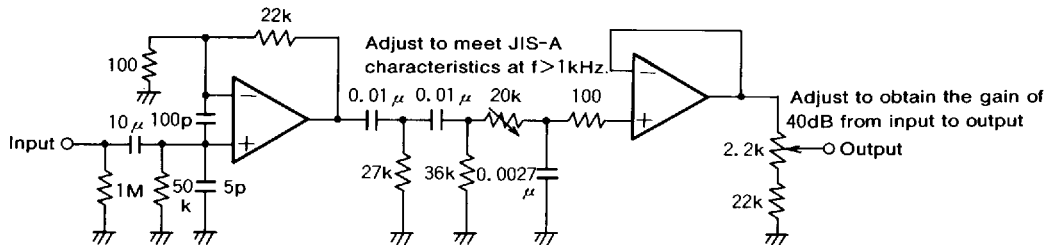

SWITCH CONDITION AND TEST METHOD

Symbol	Parameter	Switch										Test method
		S ₁₋₁	S ₁₋₂	S ₂	S ₃	S ₄	S ₅	S ₆	S ₇	S ₈₋₁	S ₈₋₂	
I _{CCO}	Circuit current	2	2	3	3	2	2	1	2	1	1	Measure the current flowing to pin ① in quiescent state
ATT _O	Attenuation	1	1	1	1	2	2	1/2	2	1	1	Obtain from the quation ATT(dB)=20 log(V _O /V _I). ATT-∞ is JIS-A in
Att-∞					2		2					
CB	Channel balance	1	1	1	3	2	2	1/2	1	1	1	
					2		1					
THD	Total harmonic distortion	1	1	1	1	2	2	1/2	2	1	1	15kHz LPF in
					2		1					
R _i	Input resistor	1	1	1	1	2	2	1	2	1→2	1→2	Given the output as V _{O1} when S ₈ →1 and the output as V _{O2} when S ₈ →2, R _i (kΩ)=150/(V _{O1} /V _{O2} -1)
							2					
BAL	Balance attenuation	1	1	1	1	2	1	1	1	1	1	BAL(dB)=20 log(V _O /V _I)
N _{Omin}	Output noise voltage	2	2	3	3	2	2	1/2	1	1	1	JIS-A in
N _{Omax}					2		2					
V _{imax}	Maximum input voltage	1	1	2	2	2	2	1/2	2	1	1	Input signal voltage when the output distortion rate is 1%.
V _{Omax}	Maximum output voltage	1	1	1	1	2	2	1/2	2	1	1	Output signal voltage when the output distortion rate is 1%.
C _T	Crosstalk	3	1	1	1	2	2	1	1	1	1	JIS-A in C _T (dB)=20 log(V _O (V _{rms})/2(V _{rms}))
		1	3					2				
G _{vp}	Pass through voltage gain	1	1	3	3	1	2	1/2	2	1	1	G _{vp} (dB)=20 log(V _O /V _I)
C _{BP}	Pass through channel balance	1	1	3	3	1	2	1→2	2	1	1	C _{BP} (dB)=G _{vpch1} -G _{vpch2}

Note 5. If the parameter is separated into two rows, measurement is made for all the switching conditions in the upper row and all the switching conditions in the lower row.

MITSUBISHI ELEK (LINEAR)

2 CHANNEL ELECTRONIC VOLUME BALANCE

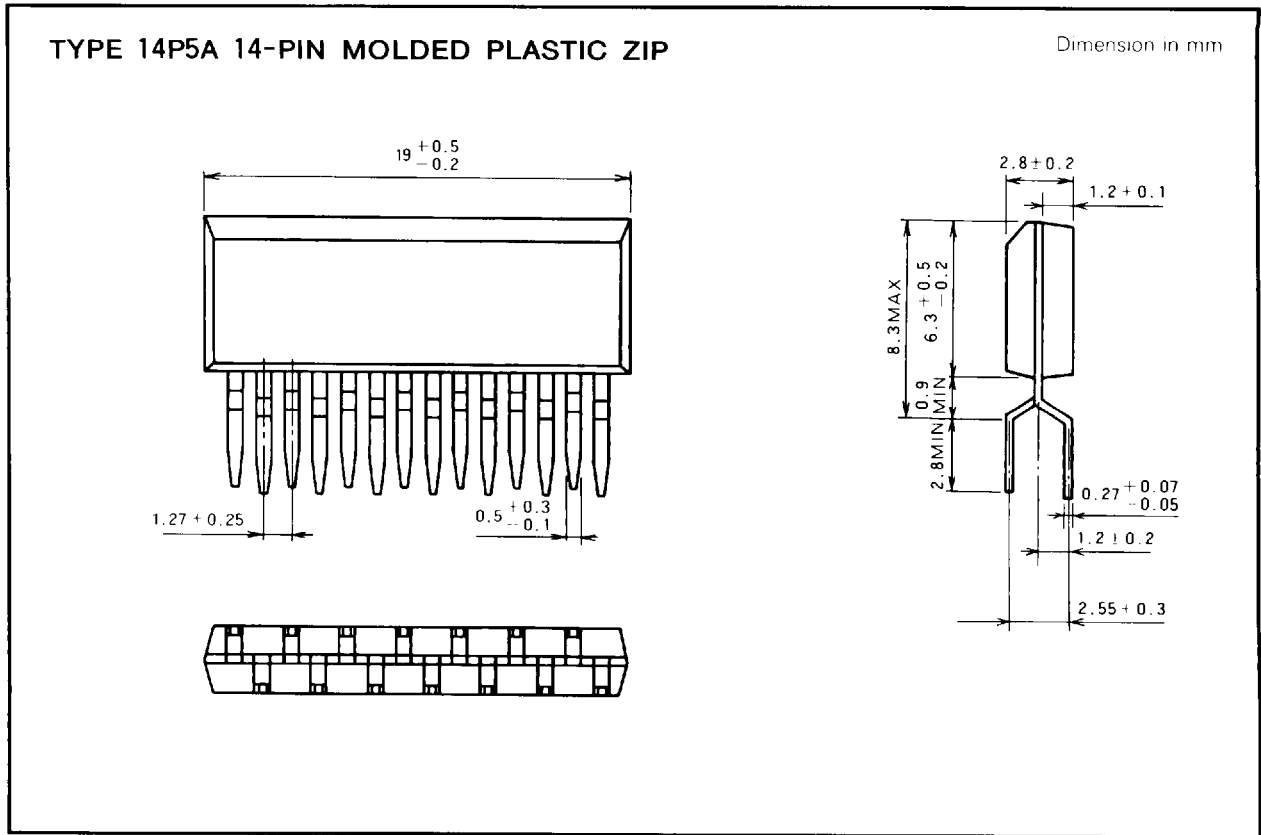

All values shown in this catalogue are subject to change for product improvement.

The information, diagrams and all other data included herein are believed to be correct and reliable. However, no responsibility is assumed by Mitsubishi Electric Corporation for their use, nor for any infringements of patents or other rights belonging to third parties which may result from their use.