

### Features

- Self-oscillation type chopper regulator power IC using Sanyo's original IMST (Insulated Metal Substrate Technology) substrate.
- The STK795, being a 5V chopper IC, is more advantageous in the following points as compared with series regulator (dropper type) ICs.
  1. Possible to provide a 5V output power supply circuit with high efficiency
  2. Since the input voltage range is wide, no more than one rectifying/smoothing circuit is required to provide a multi-output power supply circuit which also delivers 12V or 24V output.
- Functional trimming is used to set 5V output with high accuracy.
- Cutoff function to cut off output voltage by external signal
- Contains a transistor for overcurrent protector (foldback characteristic) and possible to set the protection level externally.

### Maximum Ratings at $T_a = 25^\circ\text{C}$

|                            |                          |             | unit             |
|----------------------------|--------------------------|-------------|------------------|
| Maximum DC Input Voltage   | $V_{in(DC)} \text{ max}$ | 40          | V                |
| Maximum Output Current     | $I_O \text{ max}$        | 3           | A                |
| Operating Case Temperature | $T_c$                    | 105         | $^\circ\text{C}$ |
| Junction Temperature       | $T_j$                    | 150         | $^\circ\text{C}$ |
| Storage Temperature        | $T_{stg}$                | -30 to +105 | $^\circ\text{C}$ |

### Operating Characteristics at $T_a = 25^\circ\text{C}$ , See specified Test Circuit.

|                         |       |  | min | typ | max | unit                 |
|-------------------------|-------|--|-----|-----|-----|----------------------|
| Output Voltage          | $V_O$ | $V_i = 12\text{V}, I_O = 1.5\text{A}$                | 4.9 | 5.0 | 5.1 | V                    |
| Line Regulation         |       | $V_i = 10 \text{ to } 15\text{V}, I_O = 1.5\text{A}$ |     | 70  | 100 | mV                   |
| Load Regulation         |       | $V_i = 12\text{V}, I_O = 0.5 \text{ to } 3\text{A}$  |     | 30  | 60  | mV                   |
| Efficiency              |       | $V_i = 12\text{V}, I_O = 1.5\text{A}$                |     | 72  |     | %                    |
| Frequency               | f     | $V_i = 12\text{V}, I_O = 1.5\text{A}$                |     | 35  |     | kHz                  |
| Temperature Coefficient |       | $V_i = 12\text{V}, I_O = 1.5\text{A}$                |     | 1   |     | mV/ $^\circ\text{C}$ |

### Package Dimensions 4063A (unit: mm)

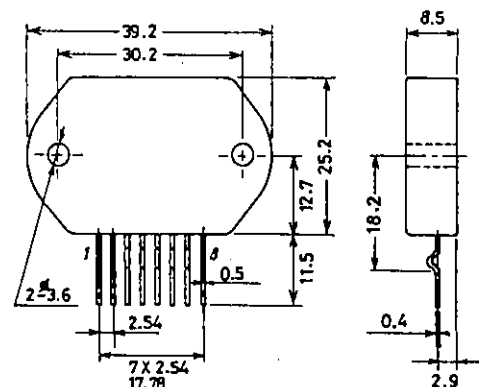

# STK795

## Equivalent Circuit

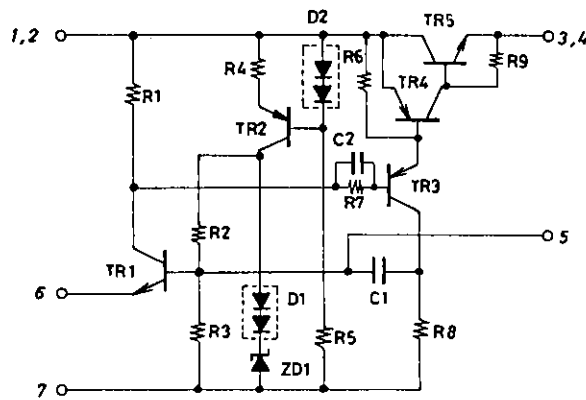

## Test Circuit

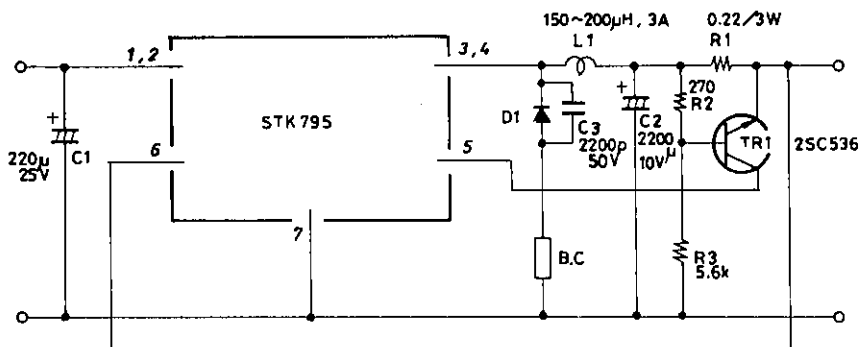

Unit (resistance:  $\Omega$ , capacitance: F)

- Note) · D1 : Schottky barrier diode SB40-05  
 · B.C. : Beads core, 2 to 3 $\mu$ H  
 · C3, B.C. are used to reduce switching spike noise.  
 · TR1 is used to provide overcurrent protection.  
 If no protection is required, remove TR1.  
 · A current of 0.5A min. must flow in the load.

■ No products described or contained herein are intended for use in surgical implants, life-support systems, aerospace equipment, nuclear power control systems, vehicles, disaster/crime-prevention equipment and the like, the failure of which may directly or indirectly cause injury, death or property loss.

■ Anyone purchasing any products described or contained herein for an above-mentioned use shall:

- ① Accept full responsibility and indemnify and defend SANYO ELECTRIC CO., LTD., its affiliates, subsidiaries and distributors and all their officers and employees, jointly and severally, against any and all claims and litigation and all damages, cost and expenses associated with such use;
- ② Not impose any responsibility for any fault or negligence which may be cited in any such claim or litigation on SANYO ELECTRIC CO., LTD., its affiliates, subsidiaries and distributors or any of their officers and employees jointly or severally.

■ Information (including circuit diagrams and circuit parameters) herein is for example only; it is not guaranteed for volume production. SANYO believes information herein is accurate and reliable, but no guarantees are made or implied regarding its use or any infringements of intellectual property rights or other rights of third parties.

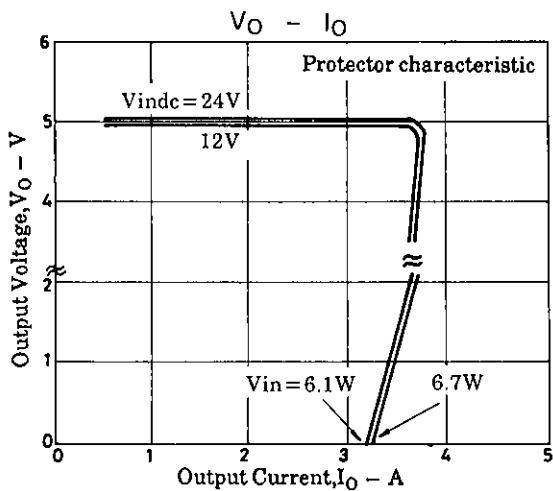
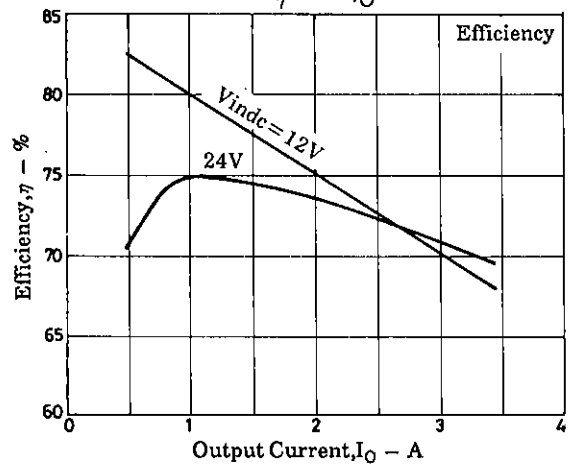
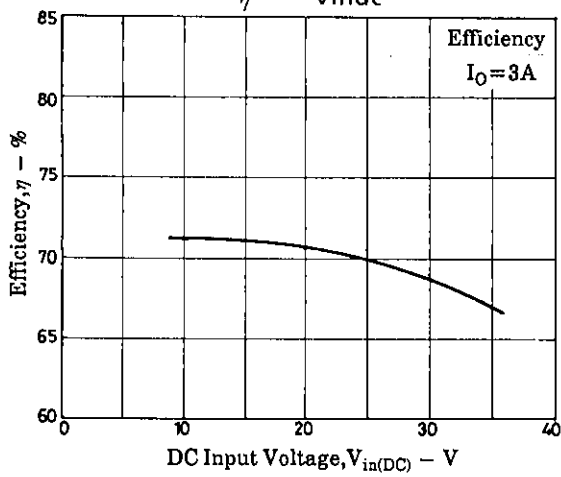
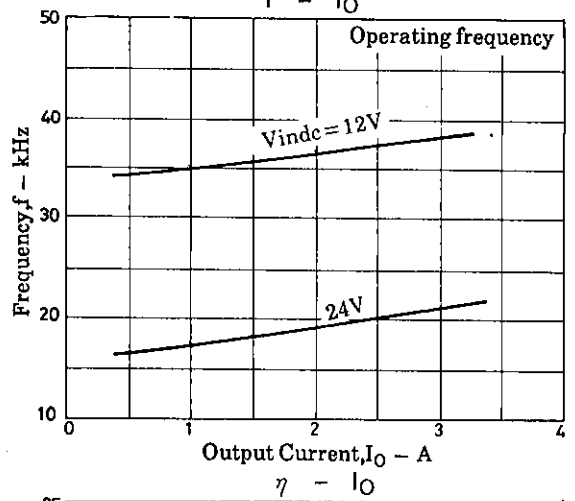
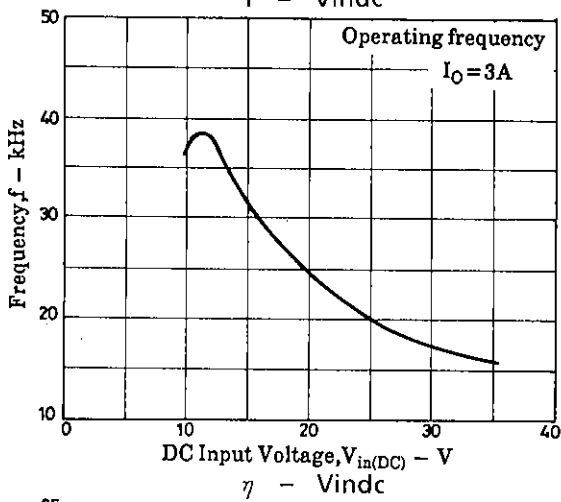
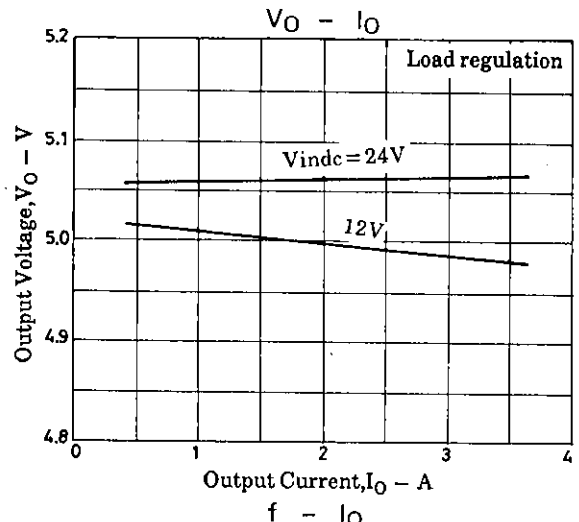
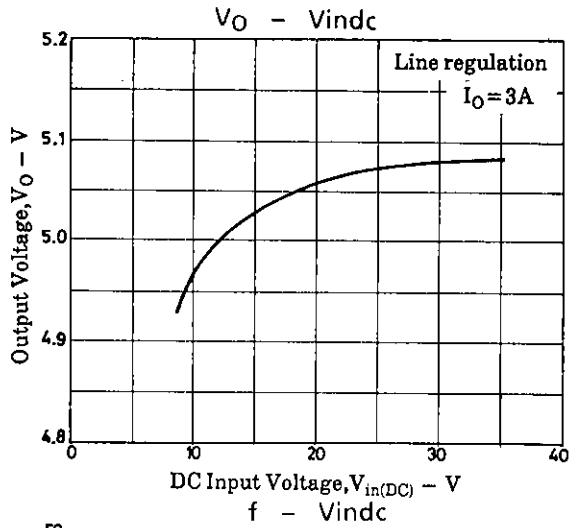

**Thermal Design**

The total internal power dissipation in the IC is related to the output current as shown below. Assuming  $V_{in(DC)} = 12V$ , output current = 3A, the total internal power dissipation is 2.7W.

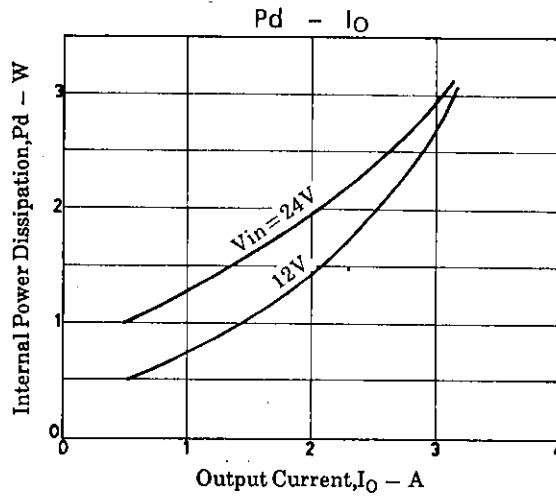

Assuming that the IC case temperature (Al plate) is 85°C ( $T_c \text{ max} = 105^\circ\text{C}$ ) and the temperature inside equipment is 60°C max., the thermal resistance required of the heat sink is as shown below.

$$\theta_{c-a} = \frac{85^\circ\text{C} - 60^\circ\text{C}}{2.7\text{W}}$$

$$= 9.3^\circ\text{C/W}$$

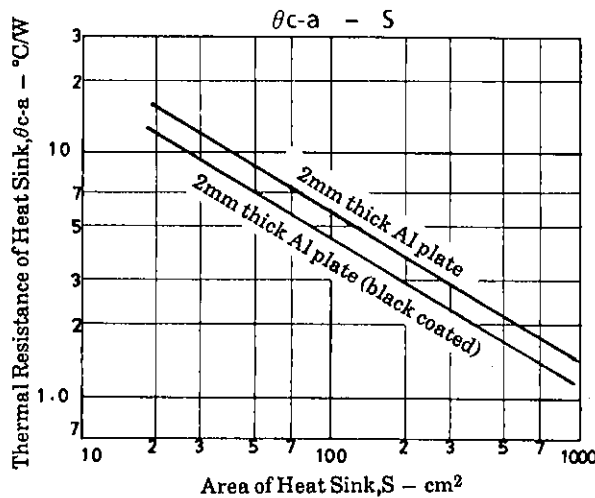

For 2mm thick Al plate (black coated), the area is 30cm<sup>2</sup>. (55 × 55 × 2t)

Junction temperature  $T_j$  of the power transistor which forms a main heat source is calculated as follows :

The thermal resistance of the power transistor is :  $\theta_{j-c} = 6.2^\circ\text{C/W}$

Therefore,  $T_j$  is calculated using  $T_j = P_d \times \theta_{j-c} + T_c$ .

$$T_j = 2.7\text{W} \times 6.2^\circ\text{C/W} + 85^\circ\text{C} = 101.7^\circ\text{C}$$

Since the actual thermal resistance of the heat sink greatly depends on various conditions such as the layout of equipment or ventilation, allow an ample margin in thermal design.