

# 2MI50F-050

SIPMOS® FUJI POWER MOS-FET

N-CHANNEL SILICON POWER MOS-FET

## MOS-FET MODULE

### ■ Features

- Low on-resistance
- High current
- Insulated to elements and metal base
- Separated two-elements
- Include fast recovery diode

### ■ Applications

- Inverters
- UPS
- A. C servo motors
- High frequency power supplies

### ■ Outline Drawings

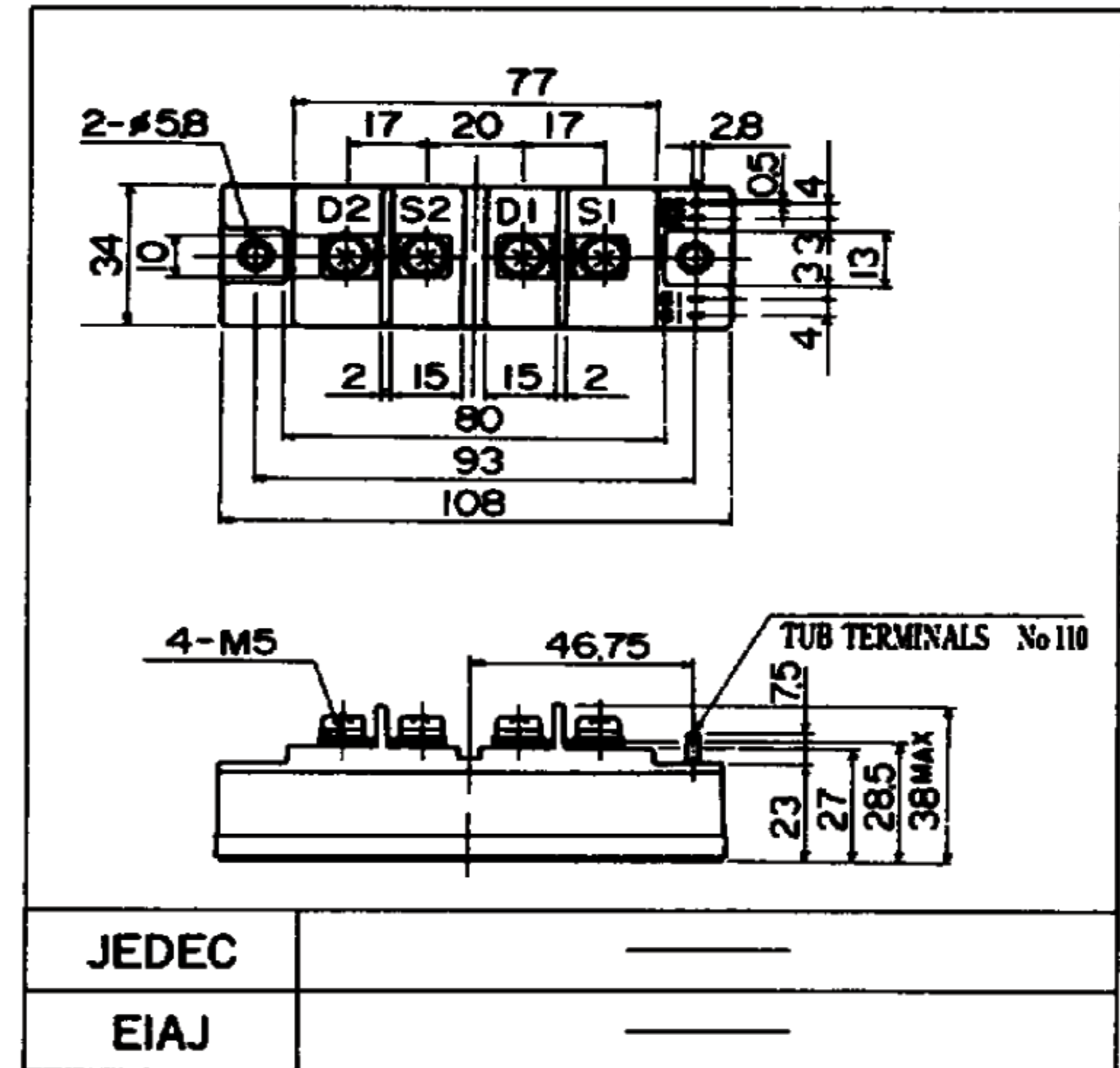

### ■ Equivalent Circuit Schematic

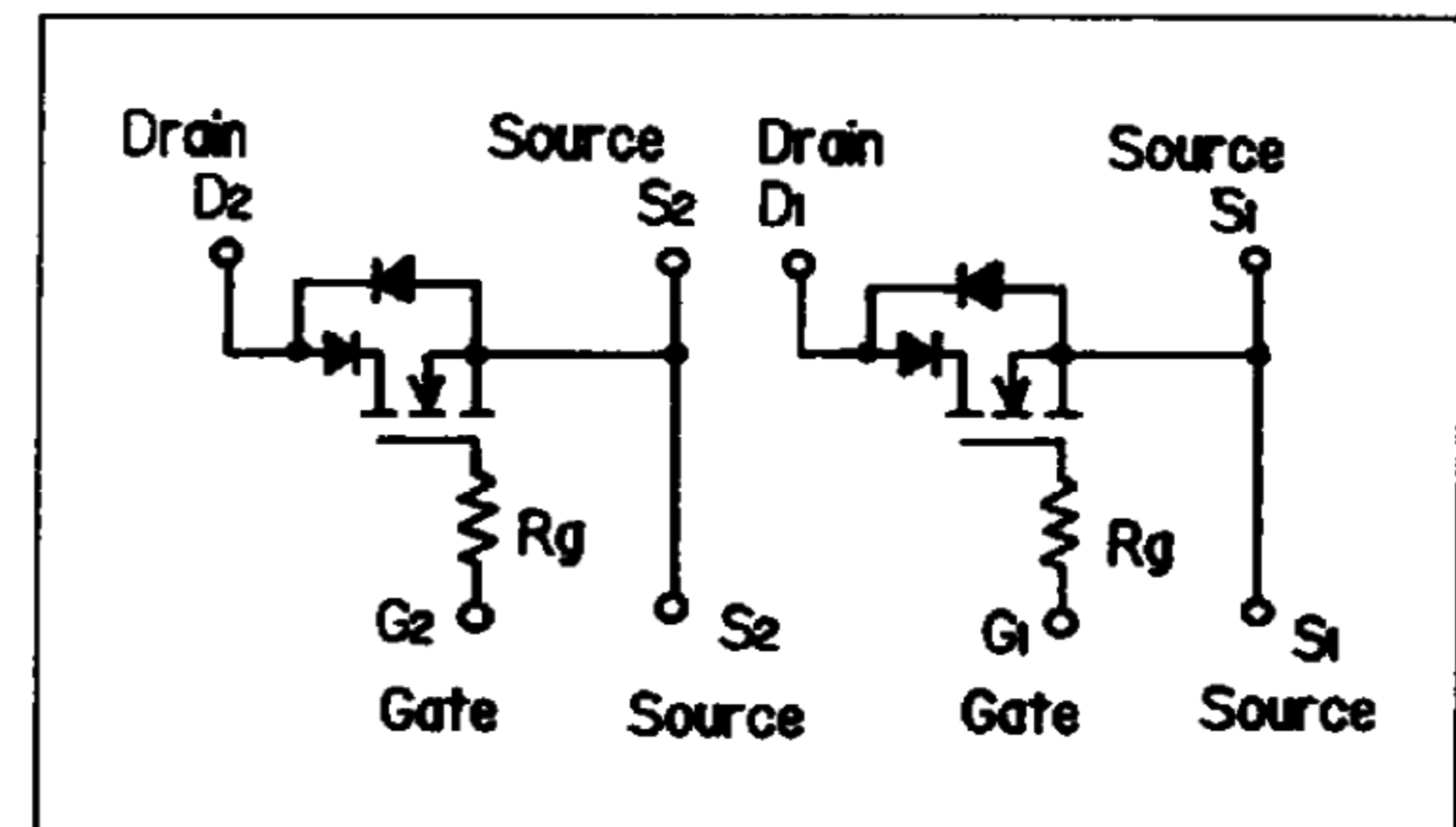

### ■ Max. Ratings and Characteristics

#### ● Absolute Maximum Ratings (Tc = 25°C)

Items	Symbols	Ratings	Units
Drain-source voltage	V <sub>DSS</sub>	500	V
Continuous drain current	I <sub>D</sub>	50	A
Pulsed drain current	I <sub>D(puls)</sub>	150	A
Continuous reverse drain current	I <sub>DR</sub>	50	A
Gate-source peak voltage	V <sub>GSS</sub>	±20	V
Max. power dissipation	P <sub>D</sub>	400	W
Operating and storage temperature range	T <sub>ch</sub>	150	°C
	T <sub>stg</sub>	-40 ~ +125	°C
Isolation test voltage	V <sub>iso</sub>	2500	V

#### ● Electrical Characteristics (Tc = 25°C)

Items	Symbols	Test Conditions	Min.	Typ.	Max.	Units
Drain-source breakdown voltage	V <sub>(BR)DSS</sub>	V <sub>GS</sub> = 0V I <sub>D</sub> = 1mA	500			V
Gate threshold voltage	V <sub>GS(th)</sub>	V <sub>DS</sub> = V <sub>GS</sub> I <sub>D</sub> = 10mA	2.1	3.0	4.0	V
Zero gate voltage drain current	I <sub>DSS</sub>	V <sub>GS</sub> = 0V V <sub>DS</sub> = 500V T <sub>ch</sub> = 25°C			1.0	mA
Gate-source leakage current	I <sub>GSS</sub>	V <sub>DS</sub> = 0V V <sub>GS</sub> = ±20V			100	nA
Drain-source on-state resistance	R <sub>DS(on)</sub>	V <sub>GS</sub> = 15V I <sub>D</sub> = 25A			0.11	Ω
Forward transconductance	g <sub>fs</sub>	V <sub>DS</sub> = 25V I <sub>D</sub> = 25A		45		S
Input capacitance	C <sub>iss</sub>	V <sub>GS</sub> = 0V		7.8	13	nF
Output capacitance	C <sub>oss</sub>	V <sub>DS</sub> = 25V		0.9	1.5	
Reverse transfer capacitance	C <sub>rss</sub>	f = 1MHz		0.4	0.6	
Switching time (t <sub>off</sub> = t <sub>d(off)</sub> + t <sub>r</sub> )	t <sub>on</sub>	V <sub>CC</sub> = 100V R <sub>G</sub> = 5Ω		530	750	ns
	t <sub>d(off)</sub>	I <sub>D</sub> = 25A P <sub>w</sub> = 20μs		700	1000	
	t <sub>r</sub>	V <sub>GS</sub> = 15V		80	110	
Diode forward on-voltage	V <sub>SD</sub>	I <sub>F</sub> = 50A V <sub>GS</sub> = 0V		1.4	1.8	V
Reverse recovery time	t <sub>rr</sub>	I <sub>F</sub> = 50, A - d <sub>i</sub> /d <sub>t</sub> = 100A/μs V <sub>GS</sub> = 0V			150	ns

#### ● Thermal Characteristics

Items	Symbols	Test Conditions	Min.	Typ.	Max.	Units
Thermal Resistance	R <sub>th(c-f)</sub>	case to fim		0.06		°C/W
	R <sub>th(ch-c)</sub>	channel to case			0.312	°C/W

■ Characteristics

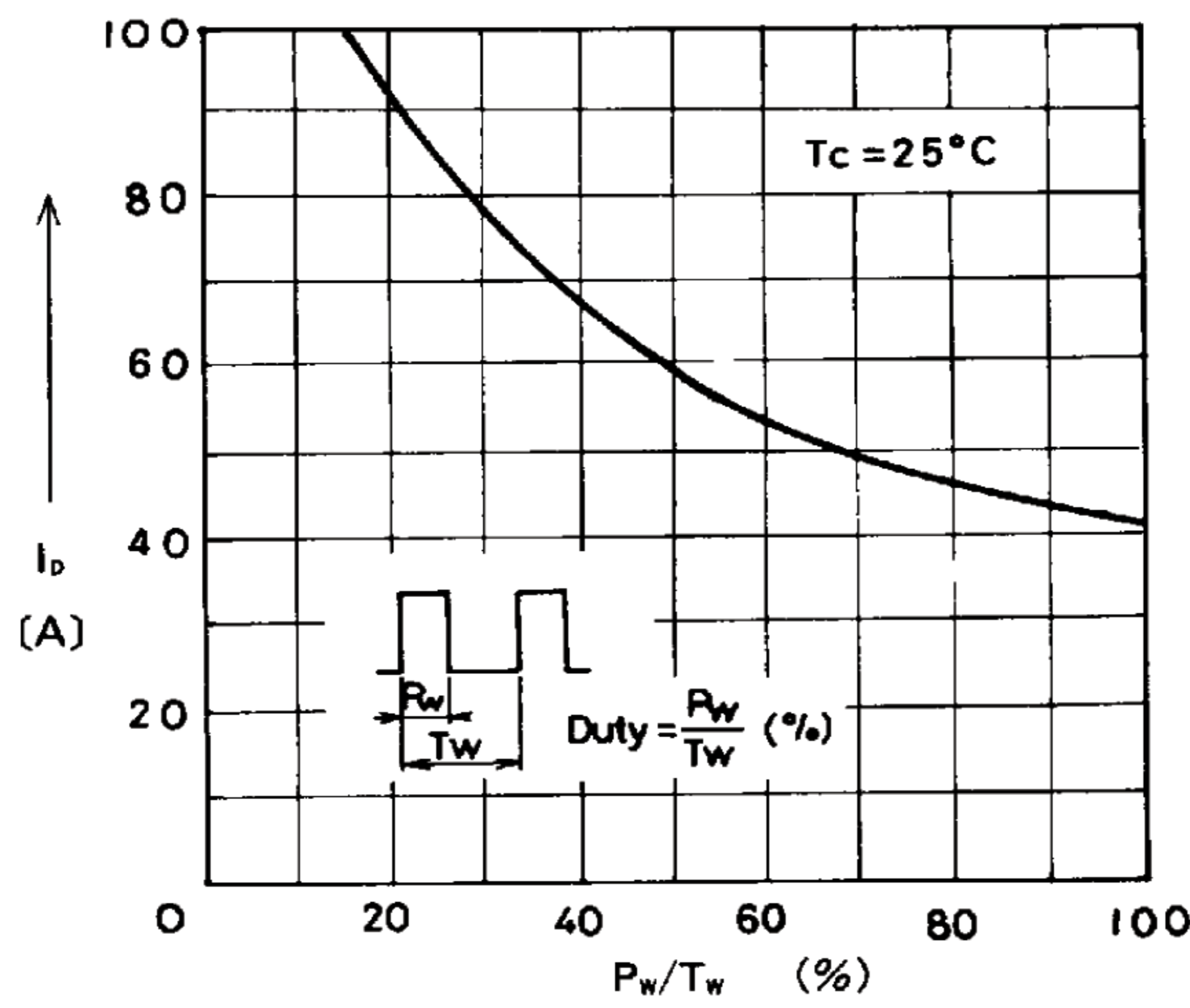

Current Duty Characteristics

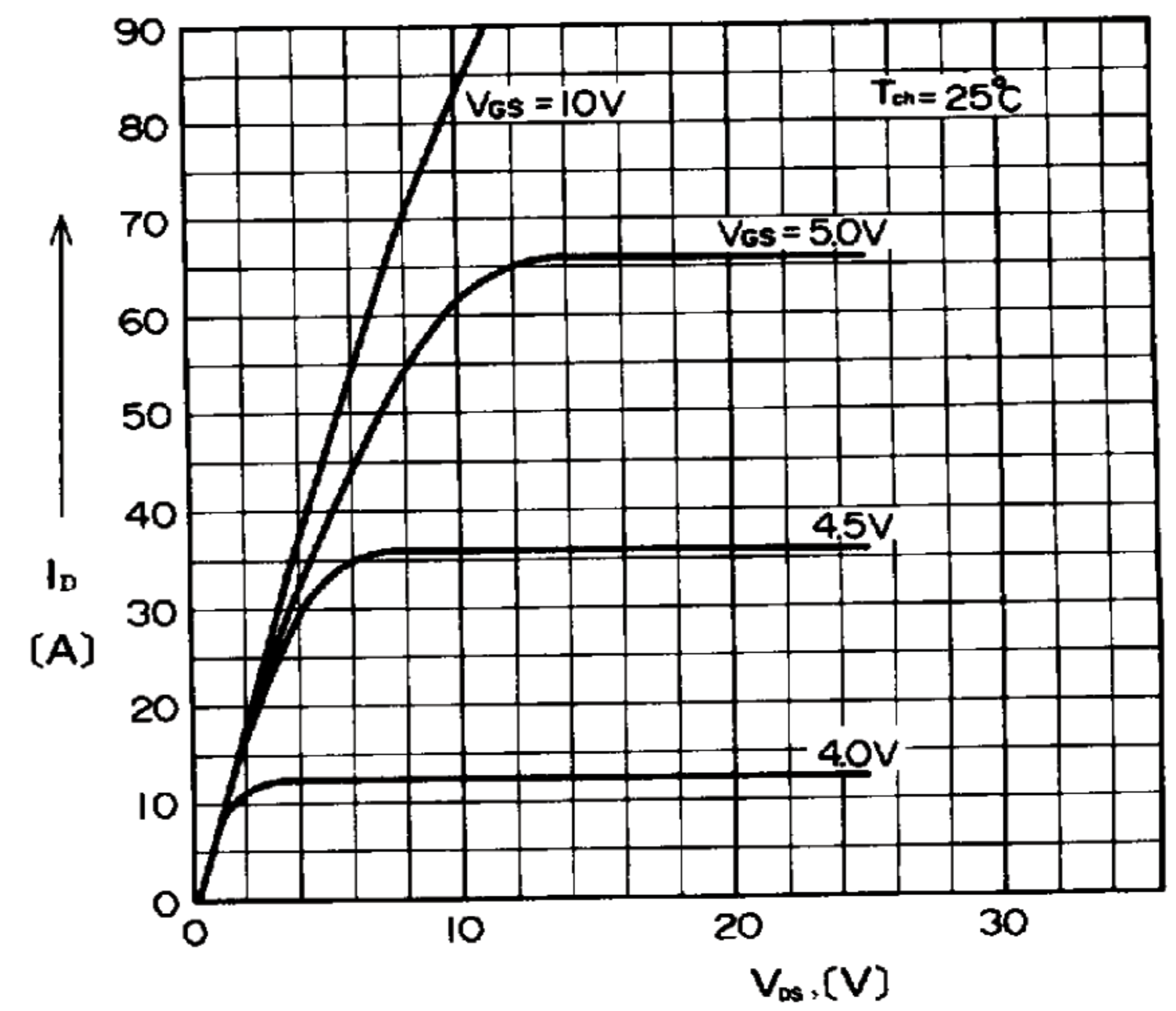

Typical Output Characteristics

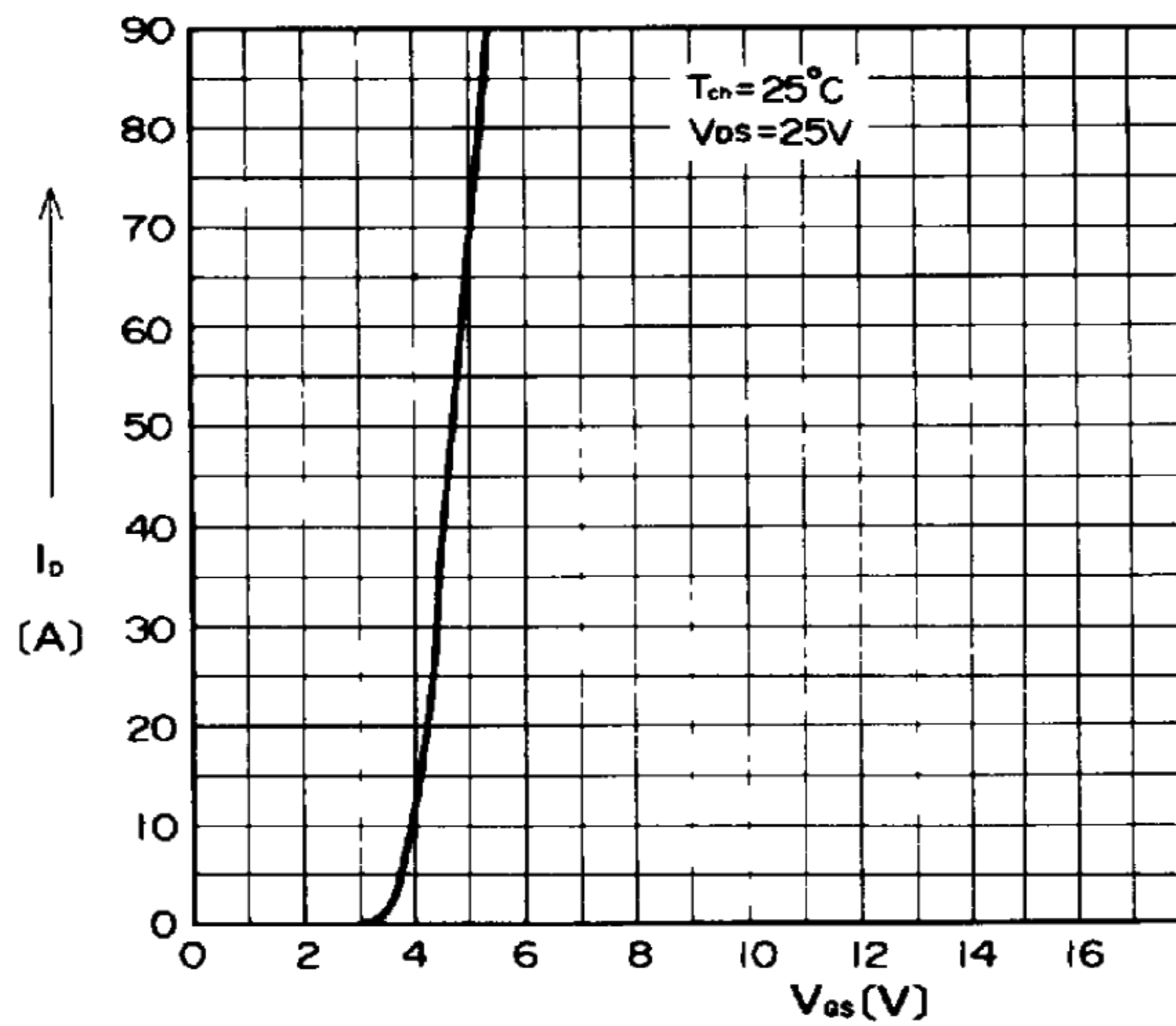

Typical Transfer Characteristics

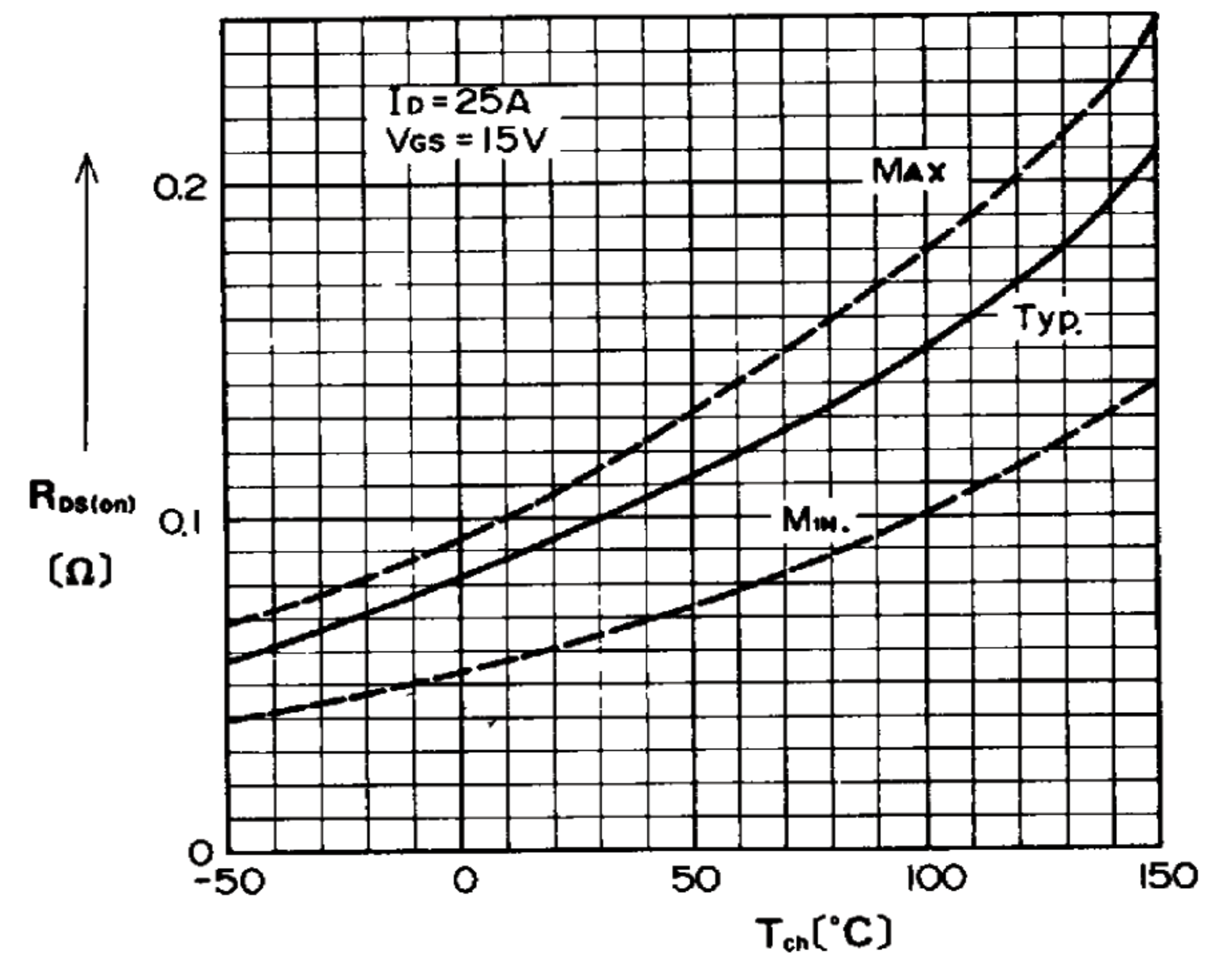

$R_{DS(on)}-T_{ch}$  Characteristics

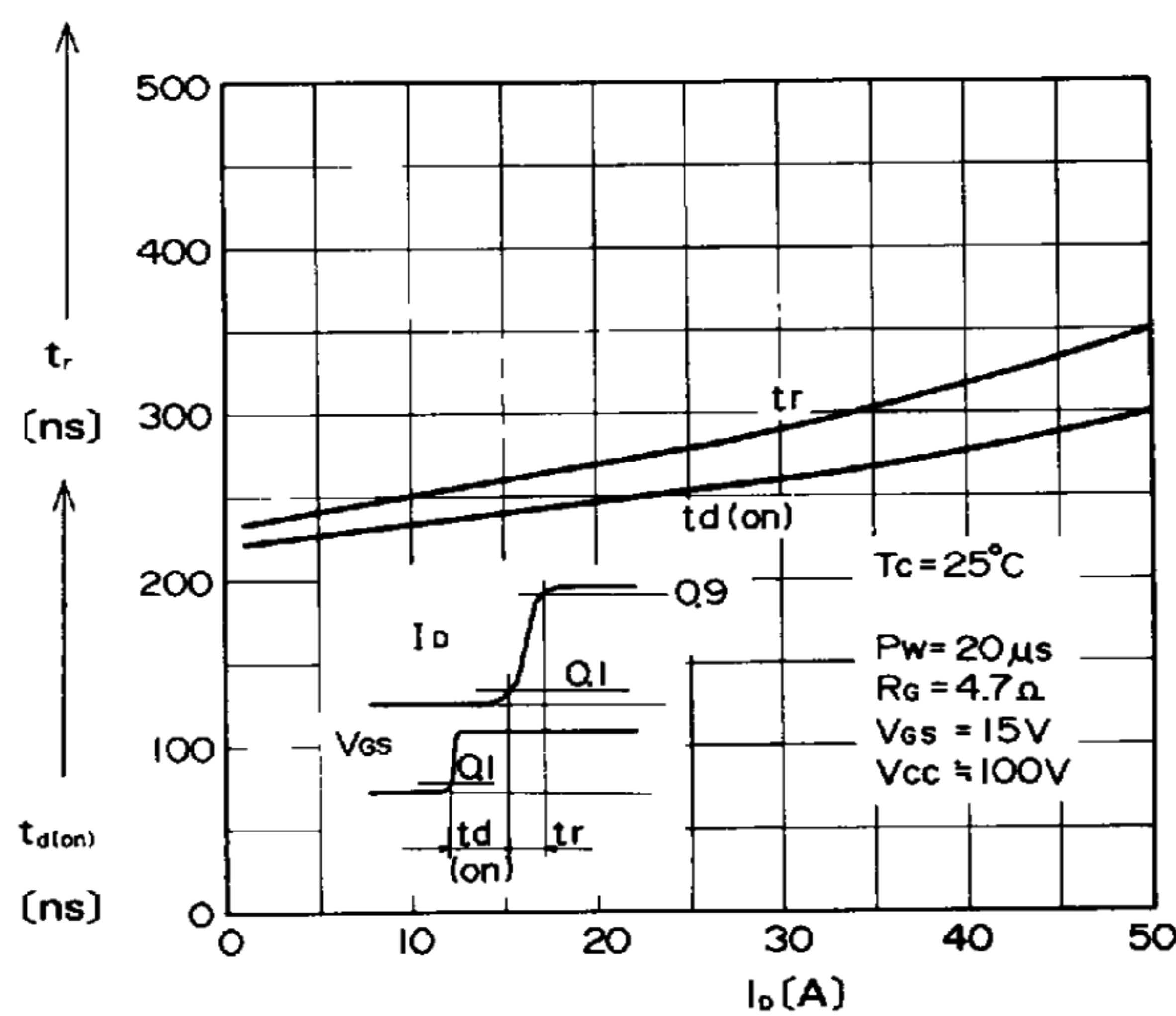

Turn-ON Characteristics

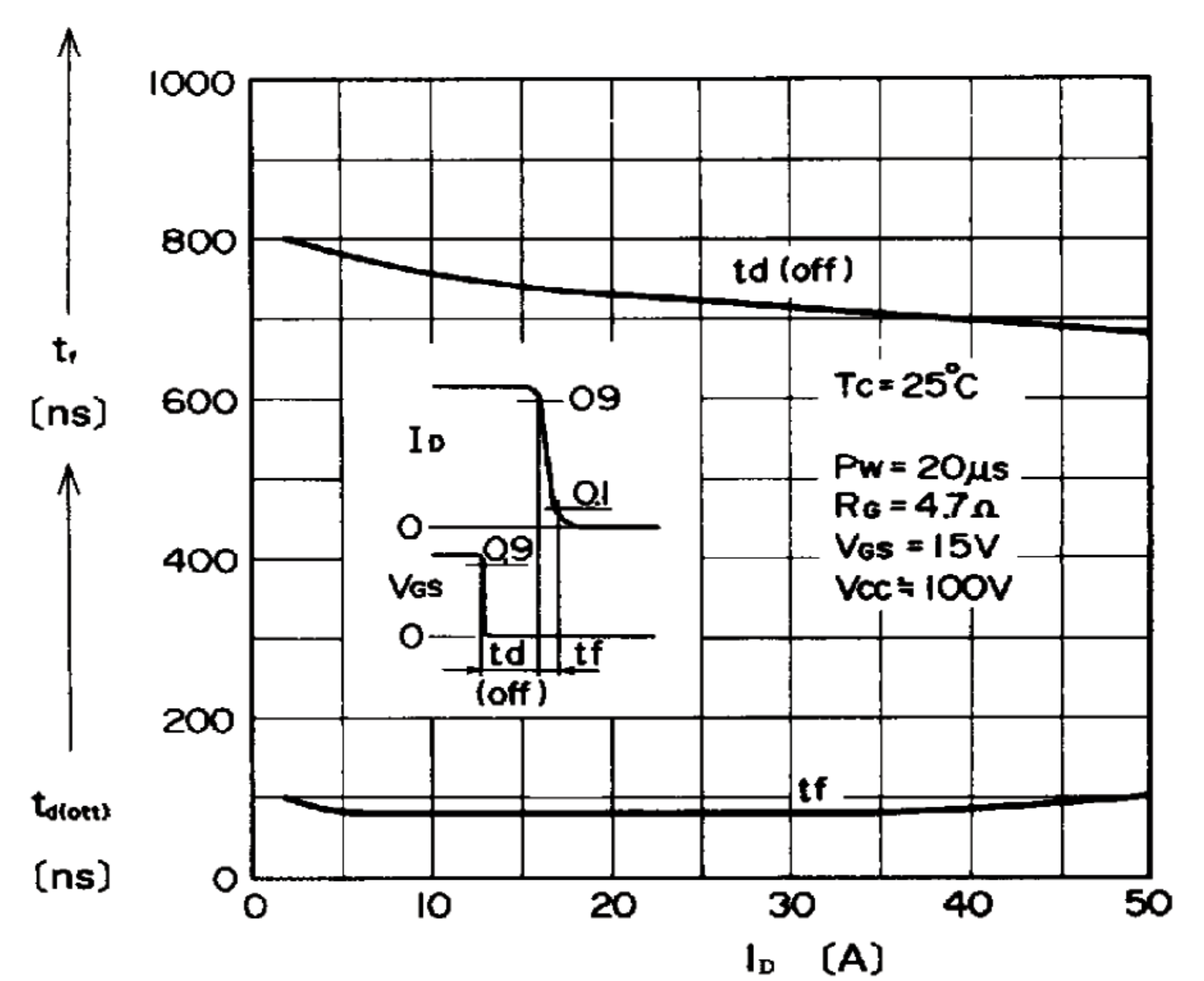

Turn-OFF Characteristics

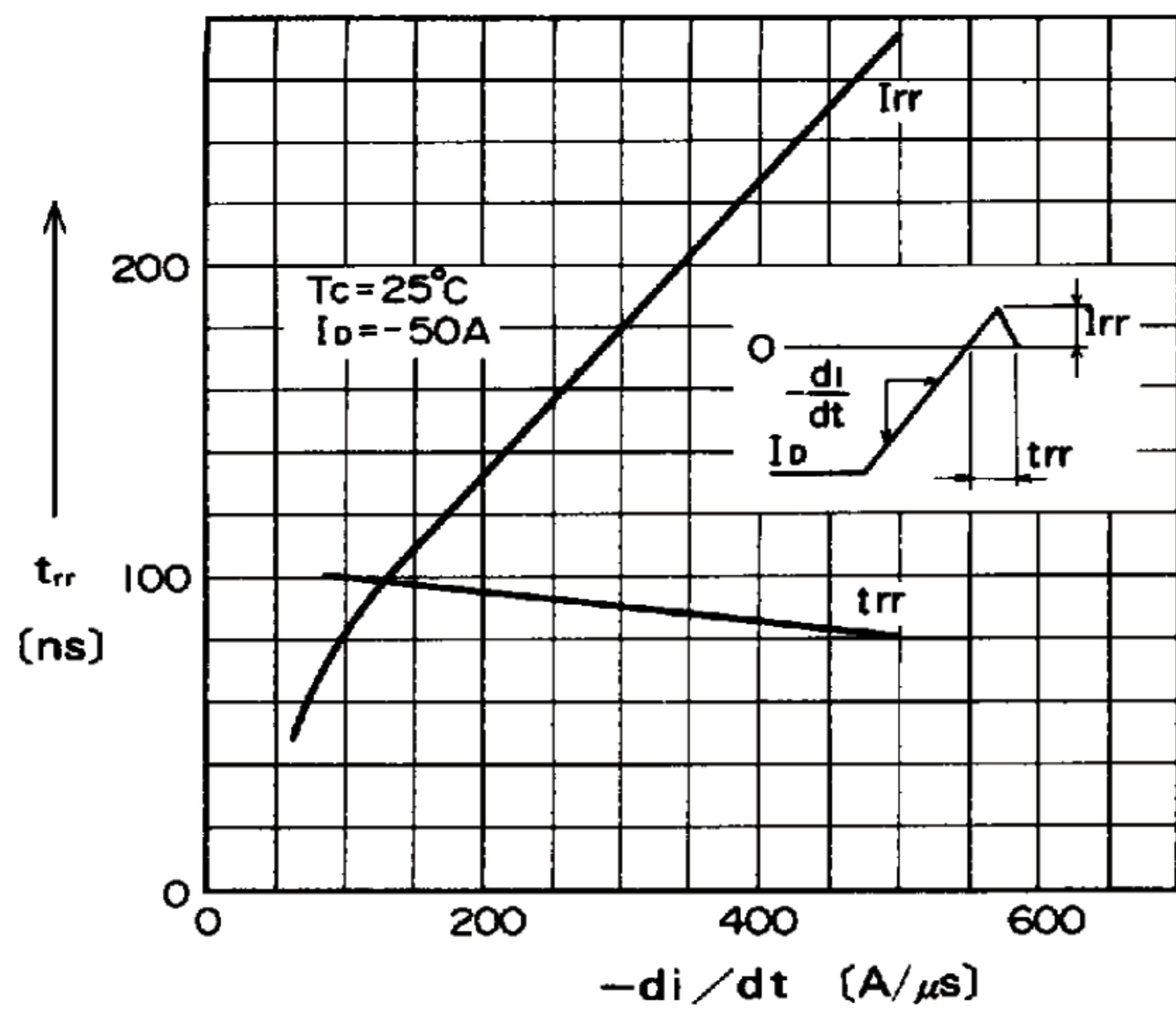

Reverse Recovery Characteristics

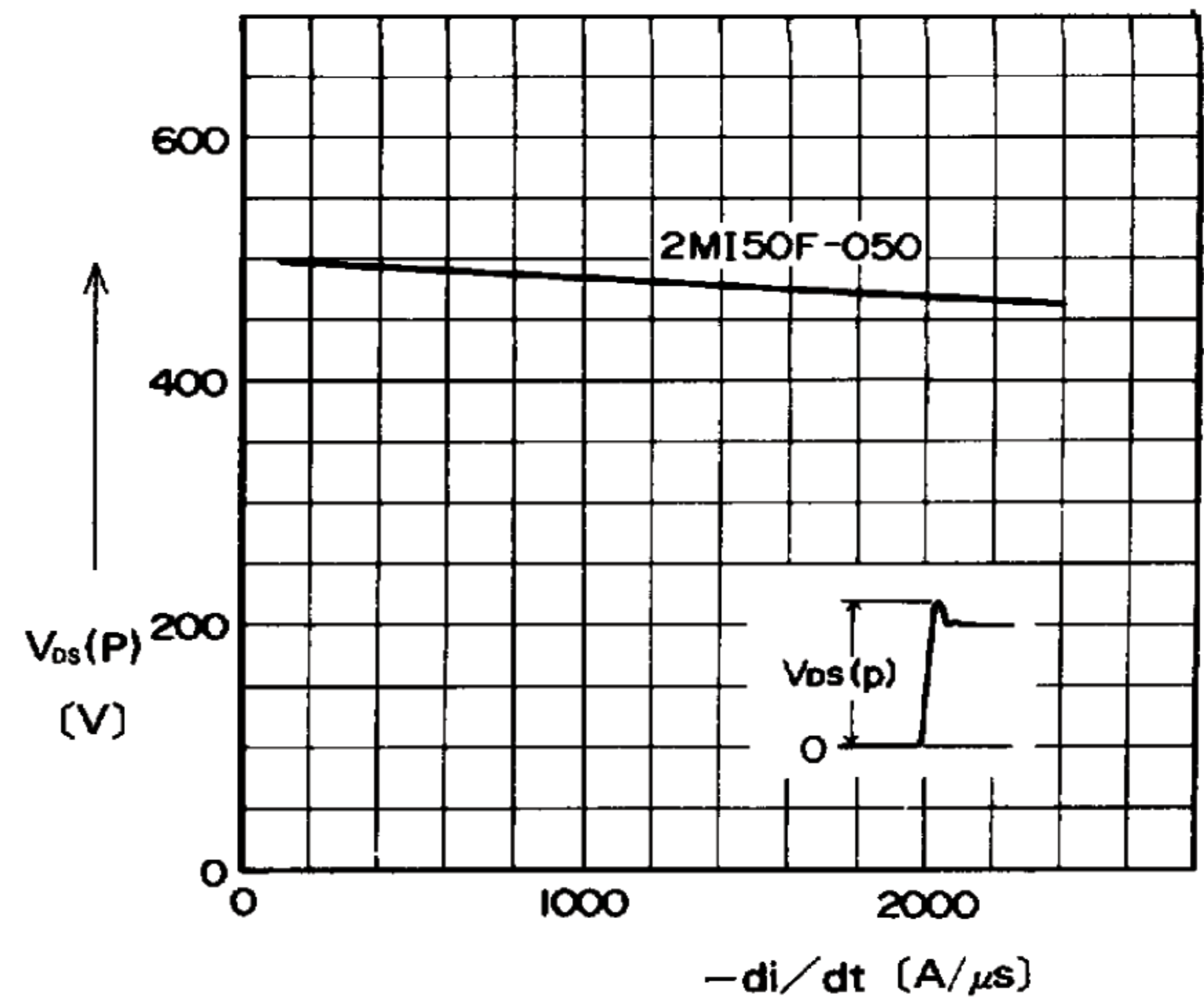

Max. Allowable  $di/dt$  at  $t_{off}$

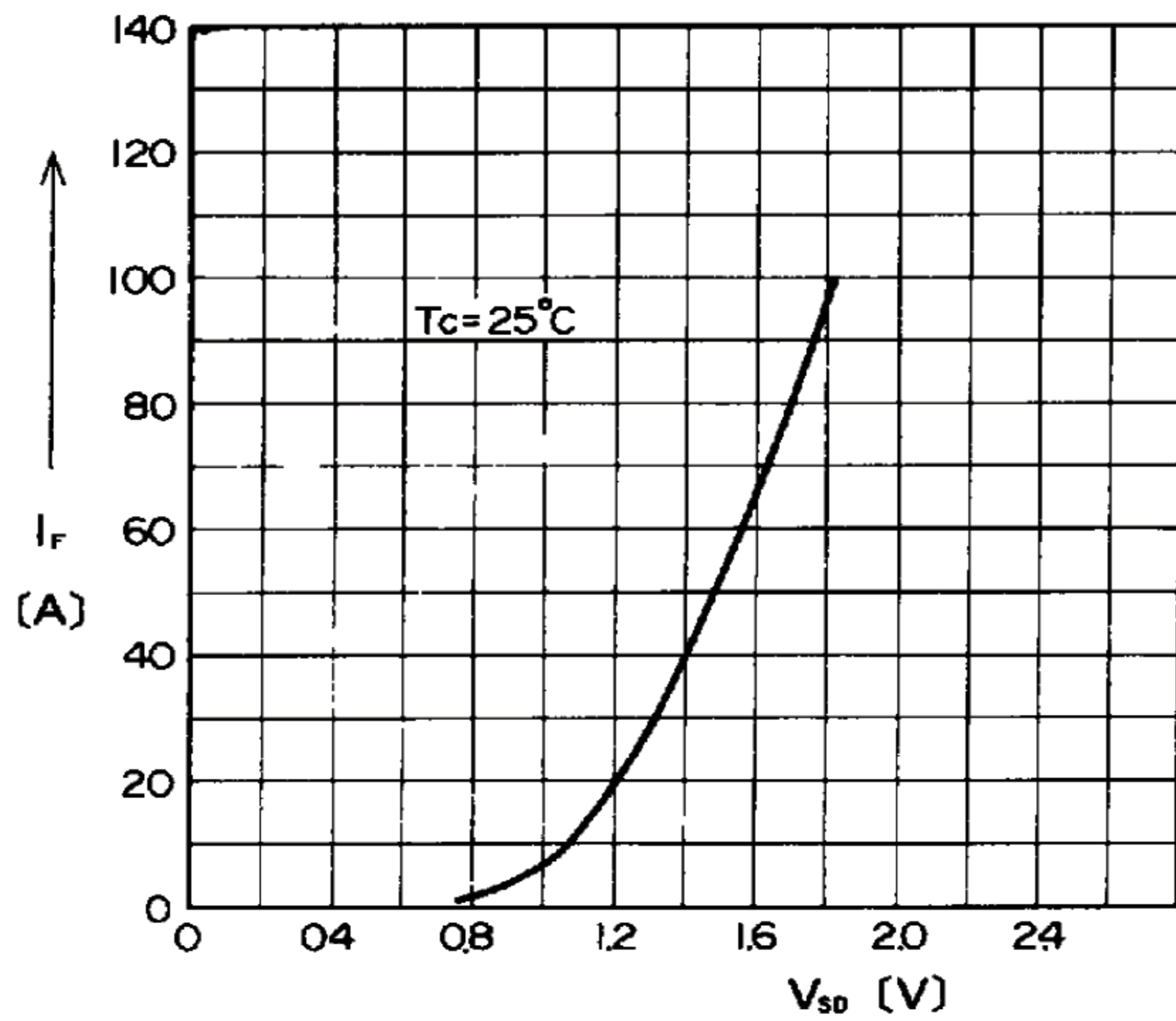

Forward Voltage of FWD

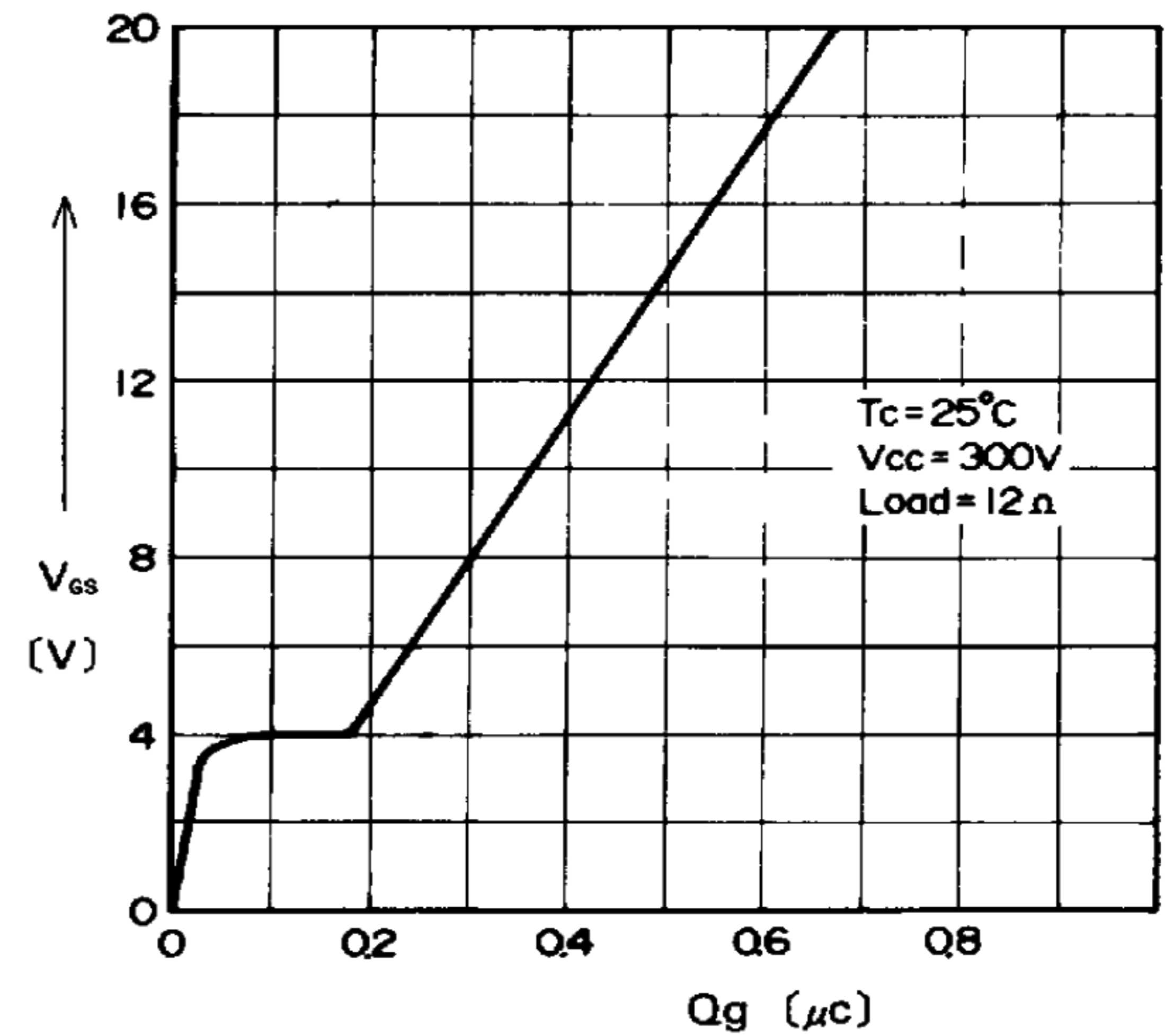

Typical Input Charge

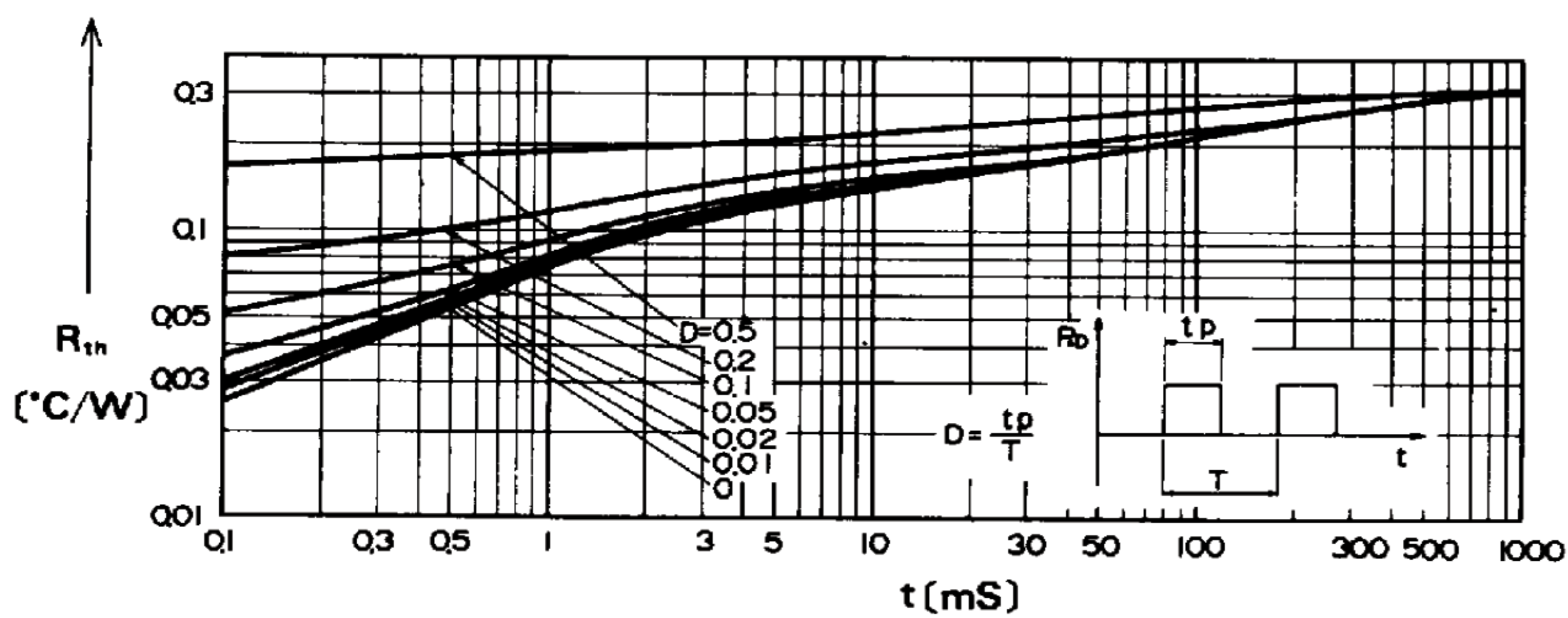

Transient Thermal Impedance

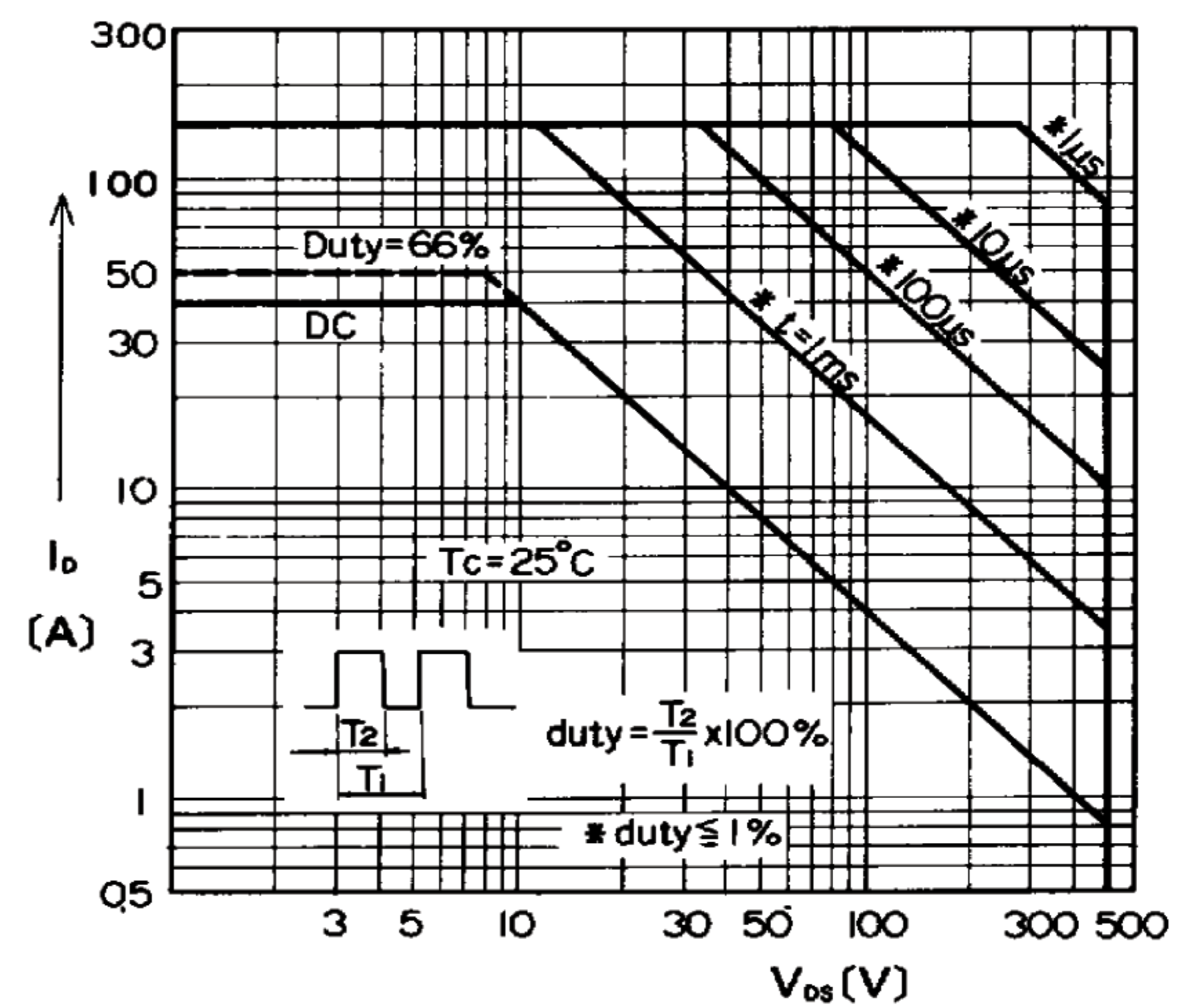

Safe Operating Area



LittleDiode supplies new, hard to find or obsolete electronic components and semiconductors all over the world.

With over two million different components listed you are sure to find the part you need.

Feel free to visit us today at our online store:

[LittleDiode.com](http://LittleDiode.com)

Looking forward to providing you with the best possible service.