

- 1N962BUR-1 thru 1N986BUR-1 AVAILABLE IN JAN, JANTX AND JANTXV PER MIL-PRF-19500/117
- ZENER DIODES
- LEADLESS PACKAGE FOR SURFACE MOUNT
- METALLURGICALLY BONDED

1N962BUR-1 thru 1N986BUR-1
and
CDLL957B thru CDLL986B

MAXIMUM RATINGS

Operating Temperature: -65°C to +175°C
Storage Temperature: -65°C to +175°C
DC Power Dissipation: 500mW @ $T_{EC} = +125^{\circ}C$
Power Derating: 10 mW / °C above $T_{EC} = +125^{\circ}C$
Forward Voltage @ 200mA: 1.1 volts maximum

ELECTRICAL CHARACTERISTICS @ 25°C

CDI TYPE NUMBER (NOTE 1)	NOMINAL ZENER VOLTAGE V_Z (NOTE 2)	ZENER TEST CURRENT I_{ZT} mA	MAXIMUM ZENER IMPEDANCE (NOTE 3)			MAX. DC ZENER CURRENT I_{ZM} mA	MAX. REVERSE LEAKAGE CURRENT $I_R @ V_R$	
			Z _{ZT} @ I_{ZT}		Z _{ZK} @ I_{ZK}		μA	VOLTS
			OHMS	OHMS				
CDLL957B	6.8	18.5	4.5	700	1.0	55	5.0	5.2
CDLL958B	7.5	16.5	5.5	700	.5	50	5.0	5.7
CDLL959B	8.2	15.0	6.5	700	.5	45	5.0	6.2
CDLL960B	9.1	14.0	7.5	700	.5	41	5.0	6.9
CDLL961B	10	12.5	8.5	700	.25	38	2.0	7.6
CDLL962B	11	11.5	9.5	700	.25	32	1.0	8.4
CDLL963B	12	10.5	11.5	700	.25	31	1.0	9.1
CDLL964B	13	9.5	13	700	.25	28	0.5	9.9
CDLL965B	15	8.5	16	700	.25	25	0.5	11
CDLL966B	16	7.8	17	700	.25	24	0.5	12
CDLL967B	18	7.0	21	750	.25	20	0.5	14
CDLL968B	20	6.2	25	750	.25	18	0.5	15
CDLL969B	22	5.6	29	750	.25	16	0.5	17
CDLL970B	24	5.2	33	750	.25	15	0.5	18
CDLL971B	27	4.6	41	750	.25	13	0.5	21
CDLL972B	30	4.2	49	1000	.25	12	0.5	23
CDLL973B	33	3.8	58	1000	.25	11	0.5	25
CDLL974B	36	3.4	70	1000	.25	10	0.5	27
CDLL975B	39	3.2	90	1000	.25	9.5	0.5	30
CDLL976B	43	3.0	93	1500	.25	8.8	0.5	33
CDLL977B	47	2.7	105	1500	.25	7.9	0.5	36
CDLL978B	51	2.5	125	1500	.25	7.4	0.5	39
CDLL979B	56	2.2	150	2000	.25	6.8	0.5	43
CDLL980B	62	2.0	185	2000	.25	6.0	0.5	47
CDLL981B	68	1.8	230	2000	.25	5.5	0.5	52
CDLL982B	75	1.7	270	2000	.25	5.0	0.5	56
CDLL983B	82	1.5	330	3000	.25	4.6	0.5	62
CDLL984B	91	1.4	400	3000	.25	4.1	0.5	69
CDLL985B	100	1.3	500	3000	.25	3.7	0.5	76
CDLL986B	110	1.1	750	4000	.25	3.3	0.5	84

- NOTE 1** Zener voltage tolerance on "B" suffix is $\pm 5\%$. Suffix letter "A" denotes $\pm 10\%$. No Suffix denotes $\pm 20\%$. "C" suffix denotes $\pm 2\%$, and "D" suffix denotes $\pm 1\%$.
- NOTE 2** Zener voltage is measured with the device junction in thermal equilibrium at an ambient temperature of $25^{\circ}C \pm 3^{\circ}C$.
- NOTE 3** Zener impedance is derived by superimposing on I_{ZT} A 60Hz rms a.c. current equal to 10% of I_{ZT} .

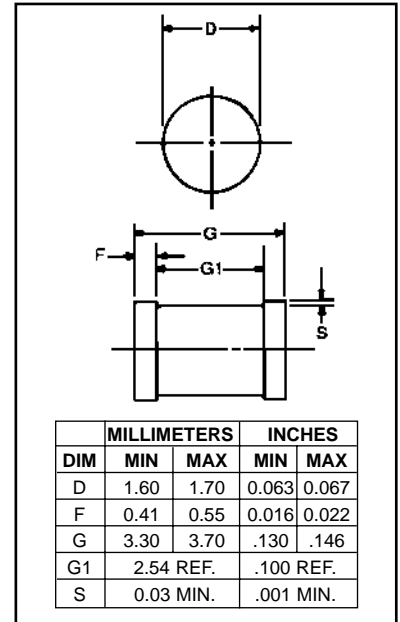

FIGURE 1

DESIGN DATA

CASE: DO-213AA, Hermetically sealed glass case. (MELF, SOD-80, LL34)

LEAD FINISH: Tin / Lead

THERMAL RESISTANCE: ($R_{\theta JEC}$): 100 °C/W maximum at L = 0 inch

THERMAL IMPEDANCE: (Z_{JX}): 35 °C/W maximum

POLARITY: Diode to be operated with the banded (cathode) end positive.

MOUNTING SURFACE SELECTION: The Axial Coefficient of Expansion (COE) Of this Device is Approximately +6PPM/°C. The COE of the Mounting Surface System Should Be Selected To Provide A Suitable Match With This Device.



COMPENSATED DEVICES INCORPORATED

22 COREY STREET, MELROSE, MASSACHUSETTS 02176
PHONE (781) 665-1071 FAX (781) 665-7379
WEBSITE: <http://www.cdi-diodes.com> E-mail: mail@cdi-diodes.com

CDLL957 thru CDLL986B

FIGURE 2

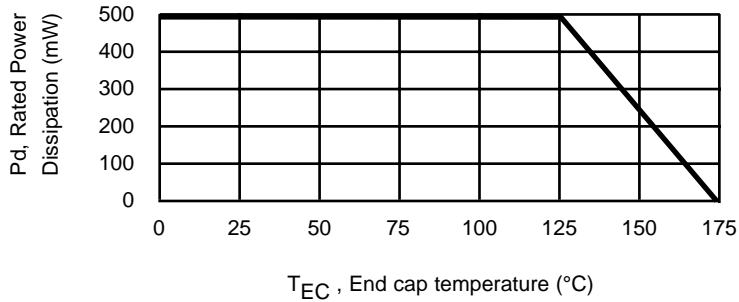

POWER DERATING CURVE

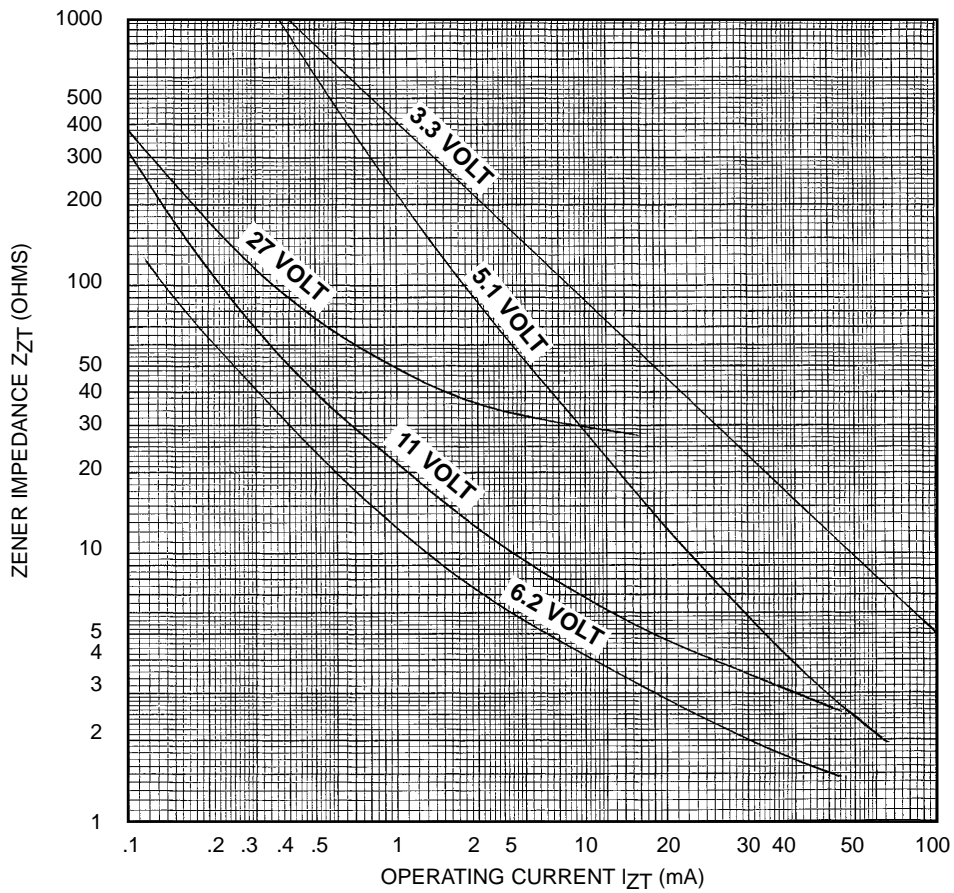

FIGURE 3

ZENER IMPEDANCE VS. OPERATING CURRENT



LittleDiode supplies new, hard to find or obsolete electronic components and semiconductors all over the world.

With over two million different components listed you are sure to find the part you need.

Feel free to visit us today at our online store:

LittleDiode.com

Looking forward to providing you with the best possible service.