

- 1N914UR AVAILABLE IN JAN, JANTX, AND JANTXV  
PER MIL-PRF-19500/116
- SWITCHING DIODE
- HERMETICALLY SEALED
- DOUBLE PLUG CONSTRUCTION
- METALLURGICALLY BONDED

**1N914UR  
and  
CDLL914**

### MAXIMUM RATINGS

Operating Temperature: -65°C to +175°C  
 Storage Temperature: -65°C to +200°C  
 Operating Current: 75 mA @  $T_A = +25^\circ\text{C}$   
 Derating Factor: 0.5 mA/°C Above  $T_A = +25^\circ\text{C}$   
 Surge Current A: 1A, sine wave,  $P_W = 8.3\text{ms}$   
 Surge Current B: 0.704A, square wave,  $P_W = 8.3\text{ms}$

### ELECTRICAL CHARACTERISTICS @ 25°C, unless otherwise specified

$V_{BR}$	$V_{RWM}$	$I_0$	$V_{f1}$ @ $I_F = 10\text{mA}$	$V_{f2}$ @ $I_F = 50\text{mA}$	$t_{rr}$ (Note 1)
Volts (min)	Volts (pk)	mA	V dc	V dc	n sec
100	75	75	0.8	1.2	5

$I_{R1}$ @ 20 V dc	$I_{R2}$ @ 75 V dc	$I_{R3}$ @ 20 V $T_A = 150^\circ\text{C}$	$I_{R4}$ @ 75 V $T_A = 150^\circ\text{C}$	CAPACITANCE @ 0 V	CAPACITANCE @ 1.5 V
nA	$\mu\text{A}$	$\mu\text{A}$	$\mu\text{A}$	pF	pF
25	0.5	35	75	4.0	2.8

NOTE 1  $I_F = I_R = 10\text{ mA}$ ,  $R_L = 100\text{ ohms}$ .

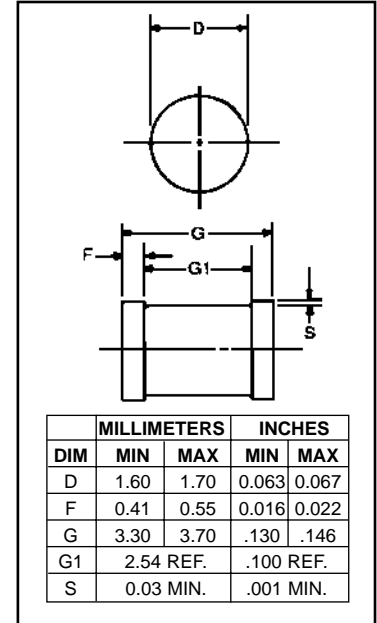

FIGURE 1

### DESIGN DATA

**CASE:** DO-213AA, Hermetically sealed glass case. (MELF, SOD-80; LL34)

**LEAD FINISH:** Tin / Lead

**THERMAL RESISTANCE ( $R_{\theta JEC}$ ):**  
100 °C/W maximum AT L = 0

**THERMAL IMPEDANCE: ( $Z_{\theta JX}$ ):** 70 °C/W maximum

**POLARITY:** Cathode end is banded.

**MOUNTING SURFACE SELECTION:**  
The Axial Coefficient of Expansion (COE) of this Device is Approximately +6PPM/°C. The COE of the Mounting Surface System Should Be Selected To Provide A Suitable Match With This Device.



**COMPENSATED DEVICES INCORPORATED**

22 COREY STREET, MELROSE, MASSACHUSETTS 02176  
 PHONE (781) 665-1071 FAX (781) 665-7379  
 WEBSITE: <http://www.cdi-diodes.com> E-mail: [mail@cdi-diodes.com](mailto:mail@cdi-diodes.com)

# IN914UR and CDLL914

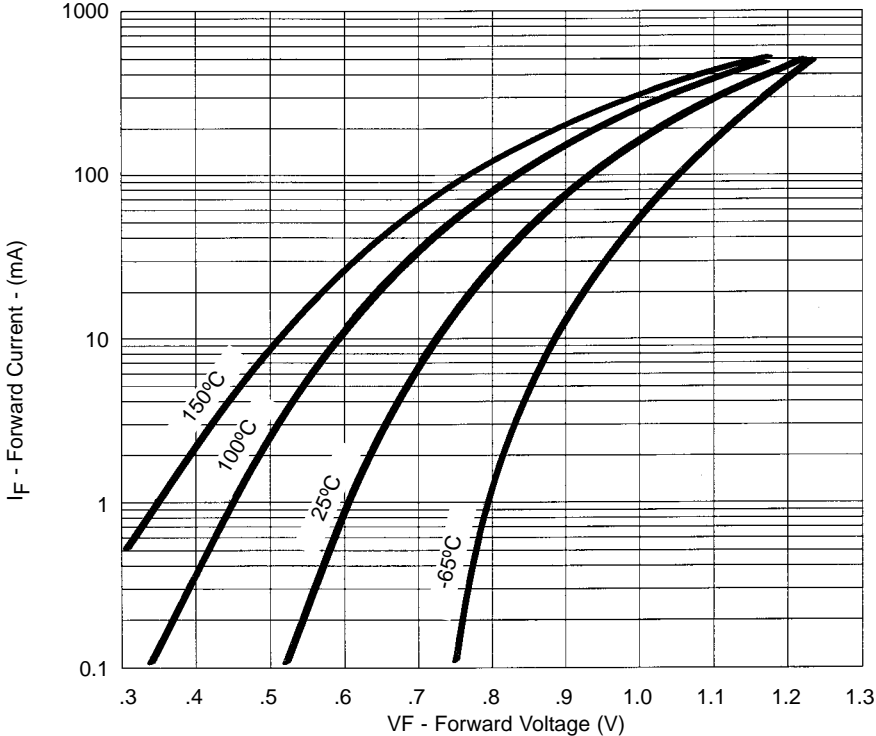

**FIGURE 2**  
Typical Forward Current  
vs Forward Voltage

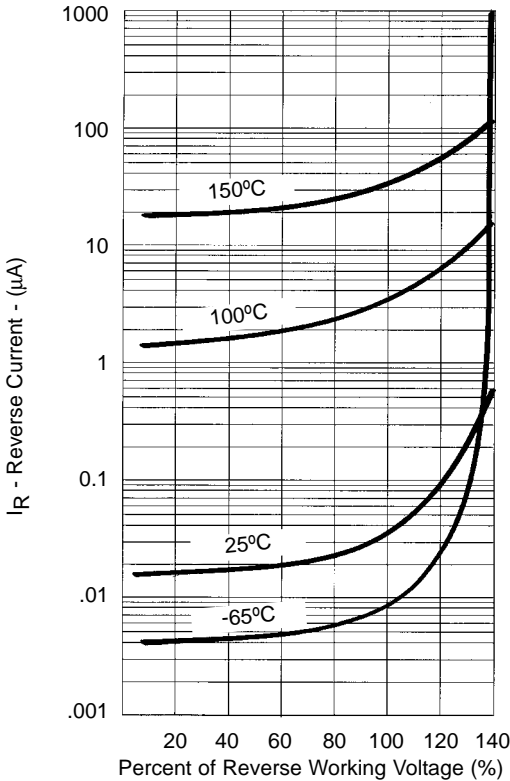

**FIGURE 3**  
Typical Reverse Current  
vs Reverse Voltage

**NOTE :** All temperatures shown on graphs are junction temperatures



LittleDiode supplies new, hard to find or obsolete electronic components and semiconductors all over the world.

With over two million different components listed you are sure to find the part you need.

Feel free to visit us today at our online store:

[LittleDiode.com](http://LittleDiode.com)

Looking forward to providing you with the best possible service.