

TOSHIBA BIPOLAR LINEAR INTEGRATED CIRCUIT SILICON MONOLITHIC

TA8400P

DUAL BRIDGE DRIVER

The TA8400P is Dual Bridge Driver designed especially for VCR cassette and tape loading motor drives.

FEATURES

- 4 modes available (CW / CCW / STOP / BRAKE)
- Output current up to 0.4 A (AVE.) and 1.0 A (PEAK)
- Wide range of operating voltage: $V_{CC} \text{ (opr.)} = 4.5\sim 18 \text{ V}$
 $V_S \text{ (opr.)} = 0\sim 22 \text{ V}$
 $V_{ref} \text{ (opr.)} = 0\sim 22 \text{ V}$
- Built-in thermal shutdown, over current protector and punch-through current restriction circuit.
- Hysteresis for all inputs.

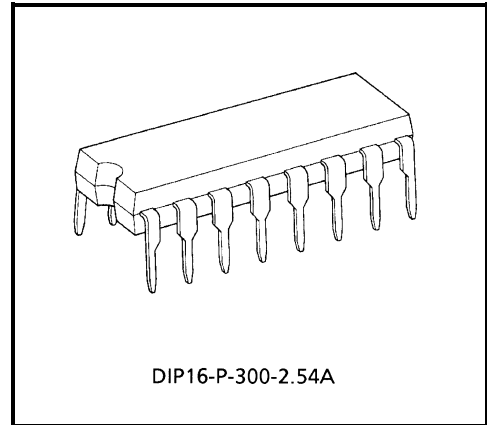

Weight: 1.11 g (Typ.)

961001EBA2

- TOSHIBA is continually working to improve the quality and the reliability of its products. Nevertheless, semiconductor devices in general can malfunction or fail due to their inherent electrical sensitivity and vulnerability to physical stress. It is the responsibility of the buyer, when utilizing TOSHIBA products, to observe standards of safety, and to avoid situations in which a malfunction or failure of a TOSHIBA product could cause loss of human life, bodily injury or damage to property. In developing your designs, please ensure that TOSHIBA products are used within specified operating ranges as set forth in the most recent products specifications. Also, please keep in mind the precautions and conditions set forth in the TOSHIBA Semiconductor Reliability Handbook.
- The products described in this document are subject to foreign exchange and foreign trade control laws.
- The information contained herein is presented only as a guide for the applications of our products. No responsibility is assumed by TOSHIBA CORPORATION for any infringements of intellectual property or other rights of the third parties which may result from its use. No license is granted by implication or otherwise under any intellectual property or other rights of TOSHIBA CORPORATION or others.
- The information contained herein is subject to change without notice.

BLOCK DIAGRAM

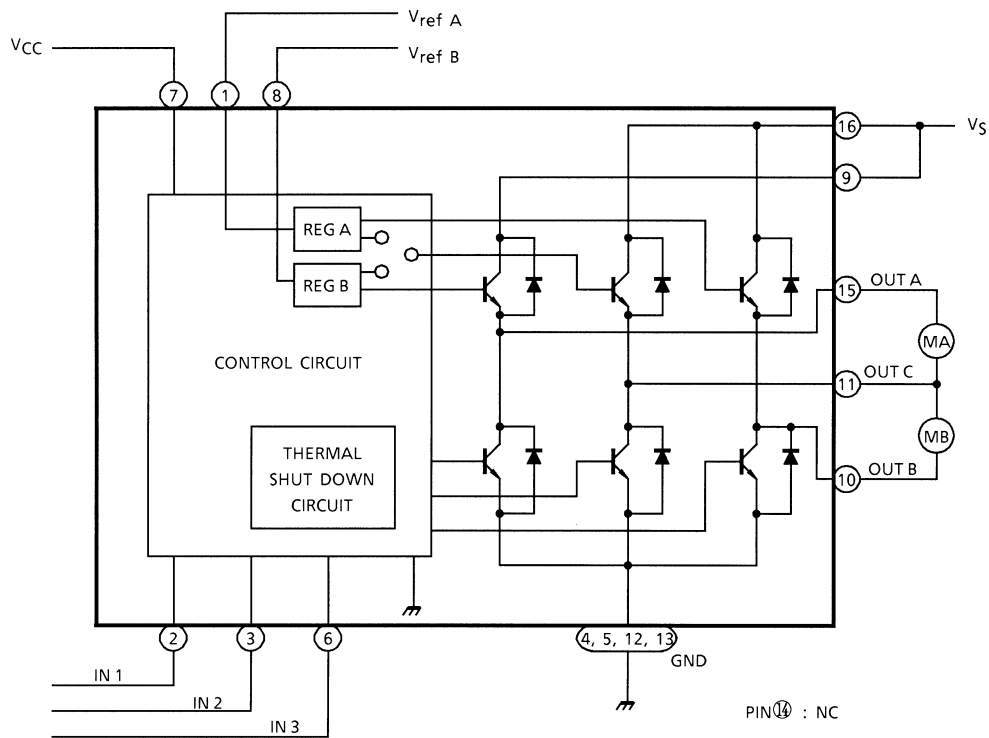

PIN FUNCTION

PIN No.	SYMBOL	FUNCTIONAL DESCRIPTION
1	V _{ref A}	Supply voltage terminal for control circuit
2	IN 1	Logic input terminal
3	IN 2	Logic input terminal
4	GND	GND terminal
5	GND	GND terminal
6	IN 3	Logic input terminal
7	V _{CC}	Supply voltage terminal for logic
8	V _{ref B}	Supply voltage terminal for control circuit
9	V _S	Supply voltage terminal for motor driver
10	OUT B	Output terminal
11	OUT C	Output terminal
12	GND	GND terminal
13	GND	GND terminal
14	NC	Non connection
15	OUT A	Output terminal
16	V _S	Supply voltage terminal for motor driver

FUNCTION

INPUT			OUTPUT			MODE	
IN 1	IN 2	IN 3	OUT C	OUT A	OUT B	MA	MB
0	0	1 / 0	∞	∞	∞	STOP	STOP
1	0	0	H	L	∞	CW / CCW	STOP
1	0	1	L	H	∞	CCW / CW	STOP
0	1	0	H	∞	L	STOP	CW / CCW
0	1	1	L	∞	H	STOP	CCW / CW
1	1	1 / 0	L	L	L	BRAKE	BRAKE

∞: High impedance

Note: Inputs are all low active type.

MAXIMUM RATINGS (Ta = 25°C)

CHARACTERISTIC	SYMBOL	RATING	UNIT
Supply Voltage	V _{CC}	25	V
Motor Drive Voltage	V _S	25	V
Reference Voltage	V _{ref}	25	V
Output Current	PEAK	I _{O (PEAK)}	1.0 (Note 1)
	AVE.	I _{O (AVE.)}	0.4
Power Dissipation	P _D	1.4 (Note 2)	W
Operating Temperature	T _{opr}	-30~75	°C
Storage Temperature	T _{stg}	-55~150	°C

Note 1: Duty 1 / 10, 100 ms

Note 2: No heat sink

ELECTRICAL CHARACTERISTICS

(Unless otherwise specified, $T_a = 25^\circ\text{C}$, $V_{CC} = 12\text{ V}$, $V_S = 12\text{ V}$)

CHARACTERISTIC		SYMBOL	TEST CIR-CUIT	TEST CONDITION	MIN	TYP.	MAX	UNIT	
Supply Current		I_{CC1}	1	Output open, CW / CCW mode	—	25	38	mA	
		I_{CC2}	1	Output open, Brake mode	—	25	38		
		I_{CC3}	1	Output open, Stop mode	—	10	20		
Input Voltage	1 (High)	V_{IN1}	2	$T_j = 25^\circ\text{C}$, pin (2), (3), (6)	3.5	—	5.5	V	
	2 (Low)	V_{IN2}	2	$T_j = 25^\circ\text{C}$, pin (2), (3), (6)	GND	—	1.2		
Input Current		I_{IN}	2	$V_{IN} = \text{GND}$, source mode	6	12	60	μA	
Input Hysteresis Voltage		ΔV_T	2		—	0.7	—	V	
Saturation Voltage		Upper	$V_{SAT U-1}$	3	$V_{ref} = V_S$, $I_O = 0.4\text{ A}$	—	1.0	1.5	V
		Lower	$V_{SAT L-1}$	3	$V_{ref} = V_S$, $I_O = 0.4\text{ A}$	—	0.3	—	
		Upper	$V_{SAT U-2}$	3	$V_{ref} = V_S$, $I_O = 1.0\text{ A}$, ON LOAD: 20 ms	—	2.0	2.5	
		Lower	$V_{SAT L-2}$	3	$V_{ref} = V_S$, $I_O = 1.0\text{ A}$, ON LOAD: 20 ms	—	0.8	1.3	
Output Voltage		$V_{SAT U-1}'$	3	$V_{ref} = 8\text{ V}$, $I_O = 0.4\text{ A}$	8.2	8.8	9.3	V	
		$V_{SAT U-2}'$	3	$V_{ref} = 8\text{ V}$, $I_O = 1.0\text{ A}$, ON LOAD: 20 ms	8.1	8.6	9.2		
Output Transistor Leakage Current		Upper	I_{LU}	—	$V_S = 25\text{ V}$	—	—	200	μA
		Lower	I_{LL}	—	$V_S = 25\text{ V}$	—	—	200	
Diode Forward Voltage		Upper	V_{FU}	4	$I_F = 1.0\text{ A}$	—	3.6	—	V
		Lower	V_{FL}	4	$I_F = 1.0\text{ A}$	—	0.9	—	
Reference Current		I_{ref}	2	$V_{ref} = 8\text{ V}$, source mode	—	0.45	0.7	mA	
Thermal Shut Down Operating Temperature		T_{SD}	—	T_j	110	130	150	$^\circ\text{C}$	

TEST CIRCUIT 3

$V_{SAT U-1, L-1, U-2, L-2, U-1', U-2'}$

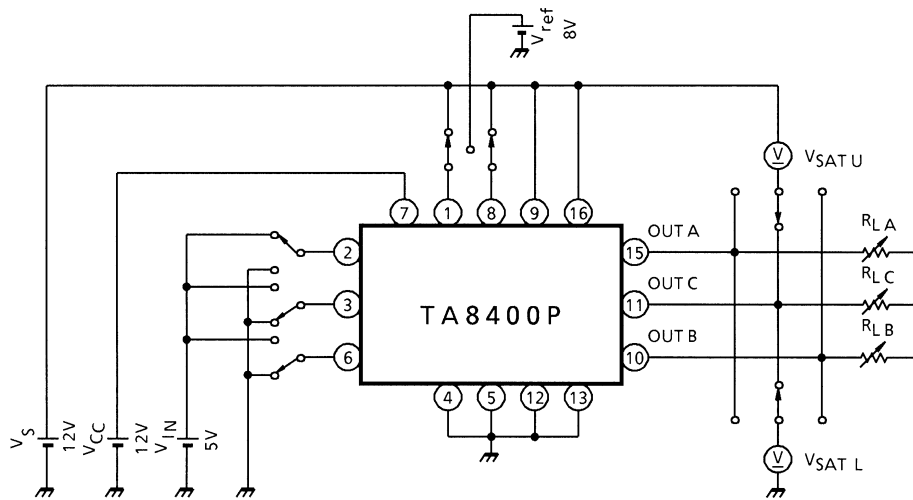

Note: Calibrate I_{OUT} to 0.4 / 1.0A by R_{LA} , R_{LB} and R_{LC} .

TEST CIRCUIT 4

$V_{FU, L}$

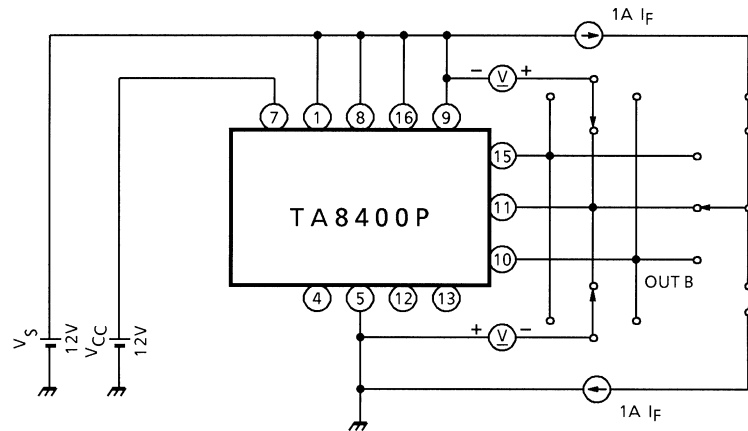

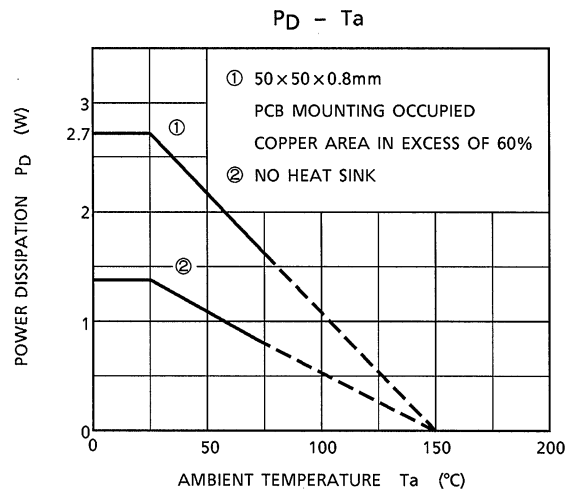

APPLICATION CIRCUIT

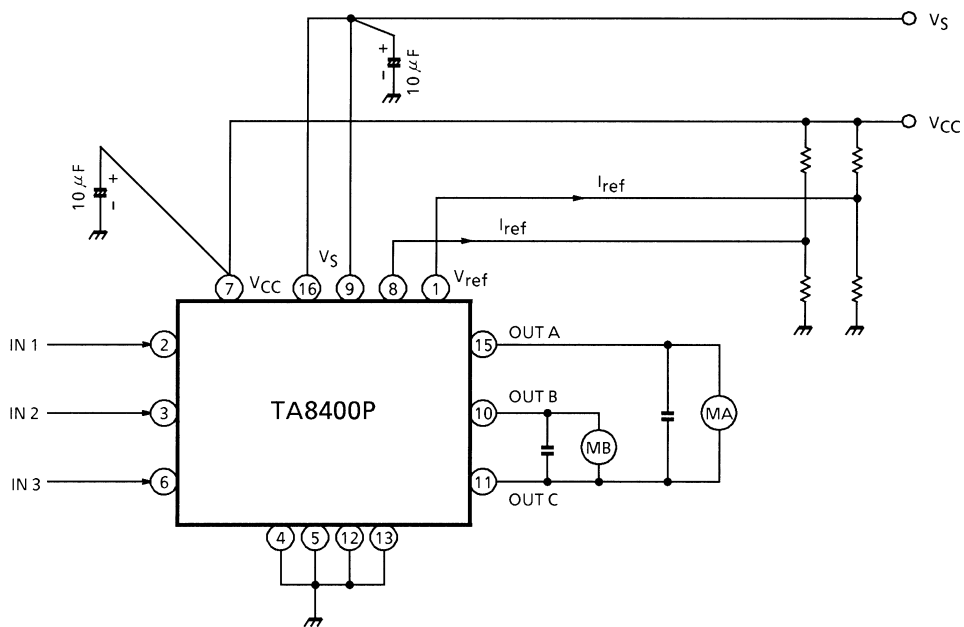

Pin (16) is required to connect to pin (9).

Note: Utmost care is necessary in the design of the output line, V_S and GND line since IC may be destroyed due to short-circuit between outputs, air contamination fault, or fault by improper grounding.

OUTLINE DRAWING

DIP16-P-300-2.54A

Unit: mm

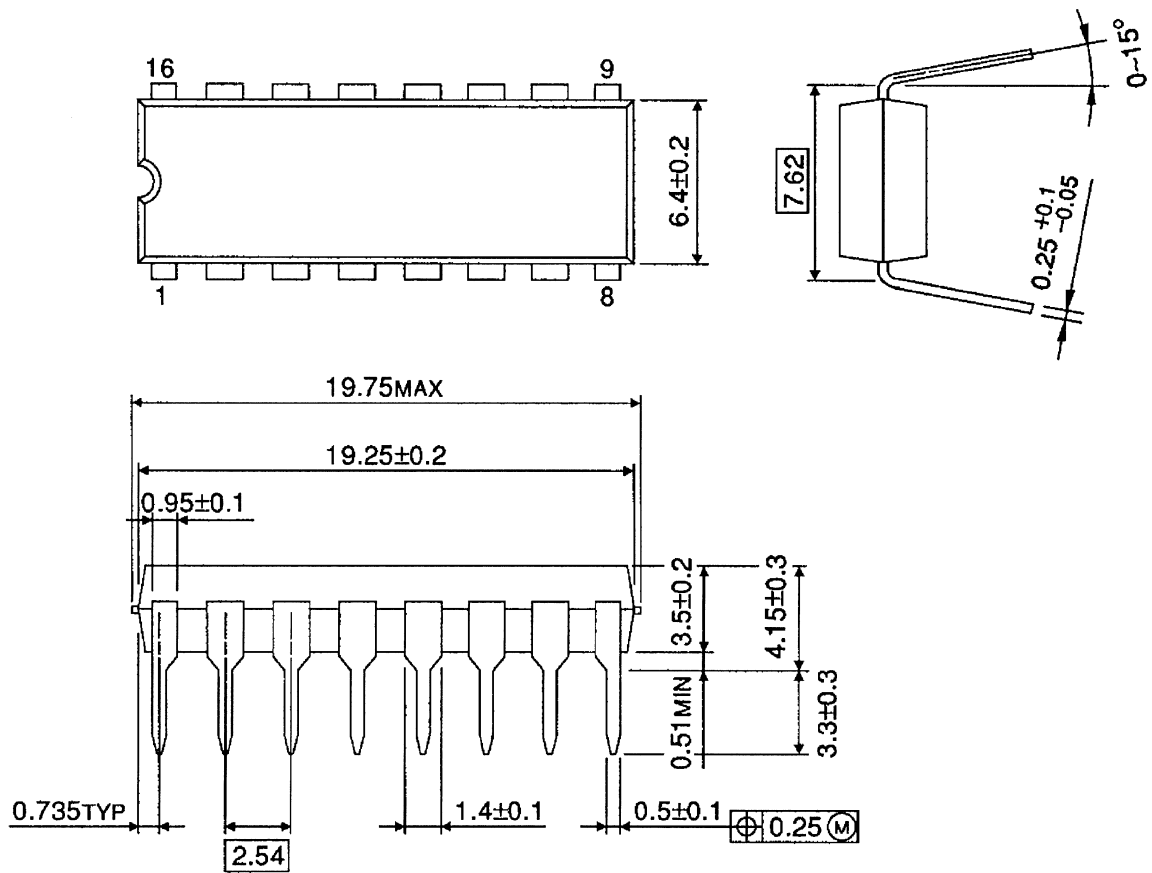

Weight: 1.11 g (Typ.)