

TA8405S

DUAL BRIDGE DRIVER

TA8405S is Dual Bridge Driver designed especially for VCR cassette and tape loading motor drives.

FEATURES

- 4 modes available (CW / CCW / STOP / BRAKE)
- Output current up to 0.4 A (AVE.) and 1.0 A (PEAK)
- Wide range of operating voltage: $V_{CC} (opr) = 4.5\sim 22\text{ V}$
 $V_S (opr) = 0\sim 22\text{ V}$
- Built-in thermal shutdown, over current protector and Punch-through current restriction circuit.
- Hysteresis for all inputs.

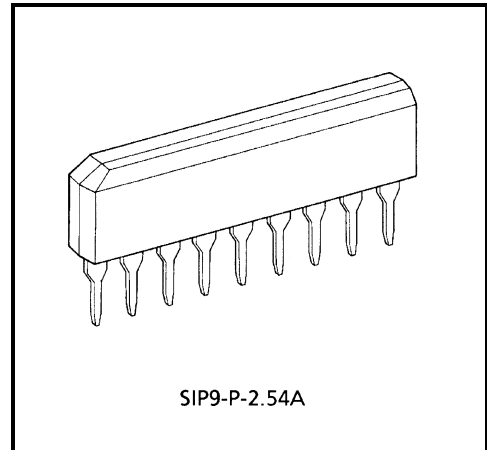

Weight: 0.92 g (Typ.)

BLOCK DIAGRAM

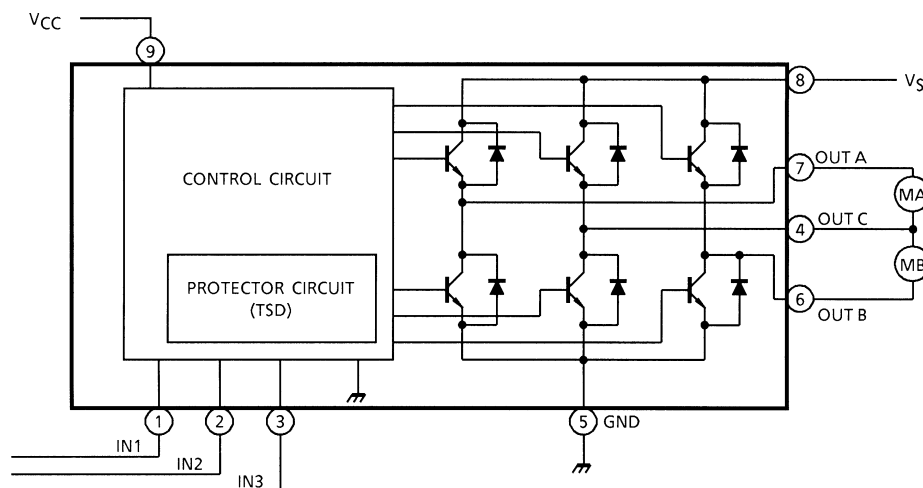

961001EBA2

- TOSHIBA is continually working to improve the quality and the reliability of its products. Nevertheless, semiconductor devices in general can malfunction or fail due to their inherent electrical sensitivity and vulnerability to physical stress. It is the responsibility of the buyer, when utilizing TOSHIBA products, to observe standards of safety, and to avoid situations in which a malfunction or failure of a TOSHIBA product could cause loss of human life, bodily injury or damage to property. In developing your designs, please ensure that TOSHIBA products are used within specified operating ranges as set forth in the most recent products specifications. Also, please keep in mind the precautions and conditions set forth in the TOSHIBA Semiconductor Reliability Handbook.
- The products described in this document are subject to foreign exchange and foreign trade control laws.
- The information contained herein is presented only as a guide for the applications of our products. No responsibility is assumed by TOSHIBA CORPORATION for any infringements of intellectual property or other rights of the third parties which may result from its use. No license is granted by implication or otherwise under any intellectual property or other rights of TOSHIBA CORPORATION or others.
- The information contained herein is subject to change without notice.

PIN FUNCTION

PIN No.	SYMBOL	FUNCTIONAL DESCRIPTION
1	IN ₁	Input terminal
2	IN ₂	Input terminal
3	IN ₃	Input terminal
4	OUT C	Output terminal
5	GND	GND terminal
6	OUT B	Output terminal
7	OUT A	Output terminal
8	V _S	Supply voltage terminal for motor drive
9	V _{CC}	Supply voltage terminal for logic

FUNCTION SPECIFICATION

(1) Input circuit

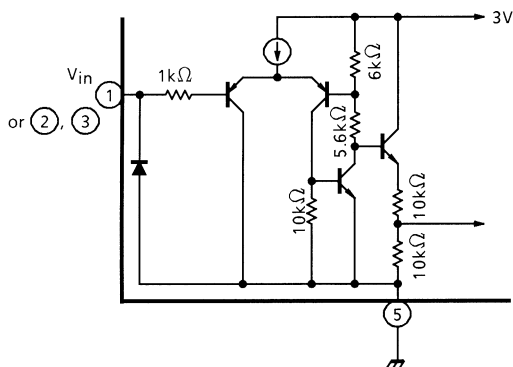

(2) Output circuit

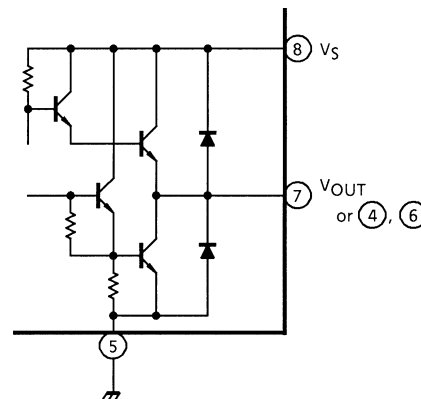

FUNCTION

INPUT			OUTPUT			MODE	
IN 1	IN 2	IN 3	OUT C	OUT A	OUT B	MA	MB
0	0	1 / 0	∞	∞	∞	STOP	STOP
1	0	0	H	L	∞	CW / CCW	STOP
1	0	1	L	H	∞	CCW / CW	STOP
0	1	0	H	∞	L	STOP	CW / CCW
0	1	1	L	∞	H	STOP	CCW / CW
1	1	1 / 0	L	L	L	BRAKE	BRAKE

∞: High impedance

Note: Inputs are all low active type.

MAXIMUM RATINGS (Ta = 25°C)

CHARACTERISTIC		SYMBOL	RATING	UNIT
Supply Voltage		V _{CC}	25	V
Motor Drive Voltage		V _S	25	V
Output Current	PEAK	I _O (PEAK)	1.0 (Note 1)	A
	AVE.	I _O (AVE.)	0.4	
Power Dissipation		P _D	0.75 (Note 2)	W
Operating Temperature		T _{opr}	-30~75	°C
Storage Temperature		T _{stg}	-55~150	°C

Note 1: Duty 1 / 10, 100 ms

Note 2: No heat sink

ELECTRICAL CHARACTERISTICS

(Unless otherwise specified, Ta = 25°C, V_{CC} = 12 V, V_S = 12 V)

CHARACTERISTIC		SYMBOL	TEST CIR-CUIT	TEST CONDITION	MIN	TYP.	MAX	UNIT
Supply Current		I _{CC1}	1	Output open, CW / CCW mode	—	7	15	mA
		I _{CC2}	1	Output open, BRAKE mode	—	15	38	
		I _{CC3}	1	Output open, STOP mode	—	7	15	
Input Operating Voltage	1 (High)	V _{IN1}	2	—	3.5	—	5.5	V
	2 (Low)	V _{IN2}	2	—	GND	—	1.2	
Input Current		I _{IN}	2	V _{IN} = GND, source mode	—	4	60	μA
Input Hysteresis Voltage		ΔV _T	2	—	—	1.5	—	V
Output Saturation Voltage	Upper	V _{SAT U-1}	3	I _O = 0.4 A, V _{OUT} -V _S measure	—	1.0	1.4	V
	Lower	V _{SAT L-1}	3	I _O = 0.4 A V _{OUT} -GND measure	—	0.8	1.2	
	Upper	V _{SAT U-2}	3	V _{OUT} -V _S measure I _O = 1.0 A, ON LOAD : 20 ms	—	1.3	2.3	
	Lower	V _{SAT L-2}	3	V _{OUT} -GND measure I _O = 1.0 A, ON LOAD : 20 ms	—	1.0	1.5	
Output Transistor Leakage Current	Upper	I _{LU}	5	V _S = 25 V	—	—	50	μA
	Lower	I _{LL}	5	V _S = 25 V	—	—	50	
Diode Forward Voltage	Upper	V _{FU}	4	I _F = 1.0 A	—	2.1	—	V
	Lower	V _{FL}	4	I _F = 1.0 A	—	1.6	—	
Thermal Shut Down Operating Temperature		T _{SD}	—	T _j	—	130	—	°C

TEST CIRCUIT 1

$I_{CC1, 2, 3}$

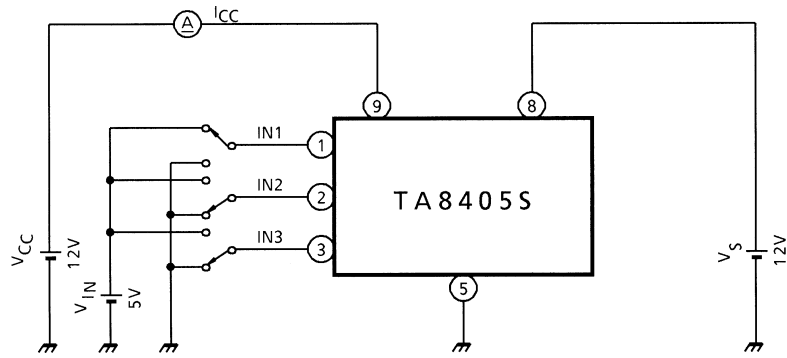

TEST CIRCUIT 2

$V_{IN1, 2}, I_{IN}, \Delta V_T$

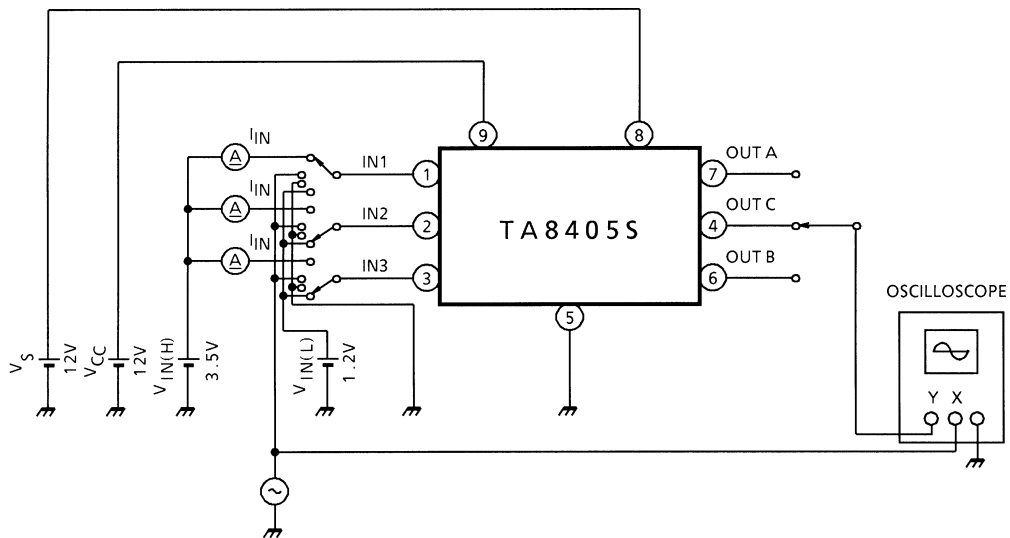

TEST CIRCUIT 3

$V_{SAT U-1, L-1, U-2, L-2}$

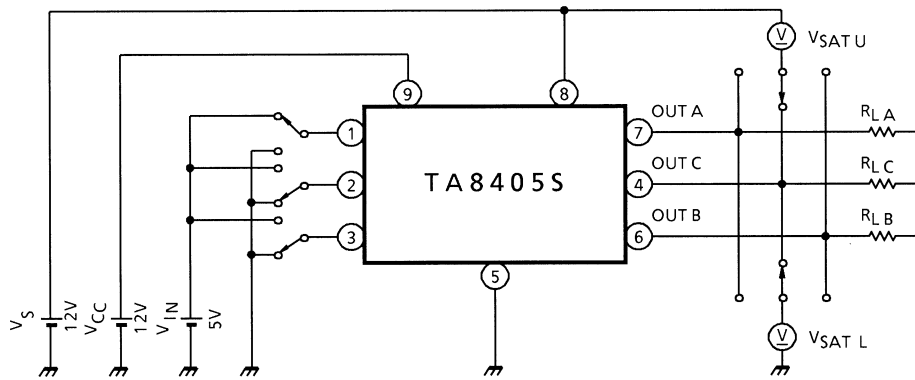

TEST CIRCUIT 4

$V_{FU, L}$

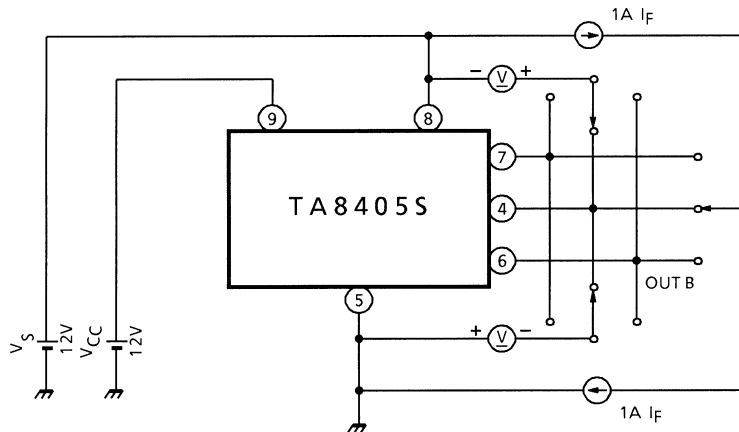

TEST CIRCUIT 5

$I_{LU, L}$

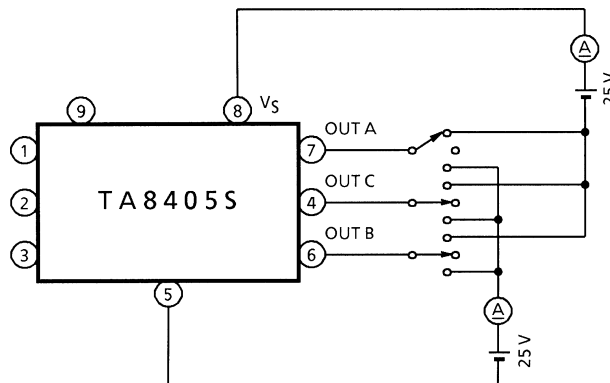

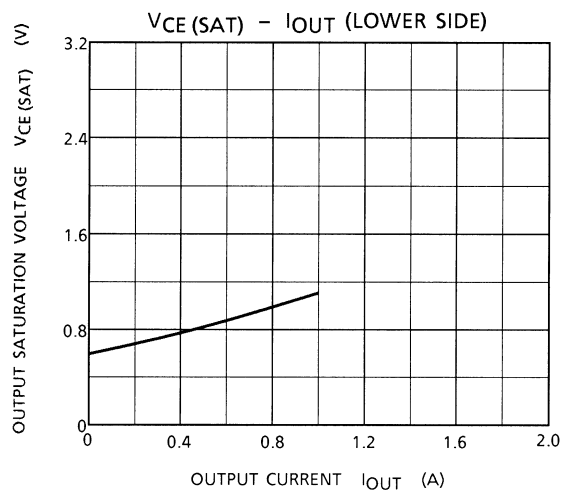
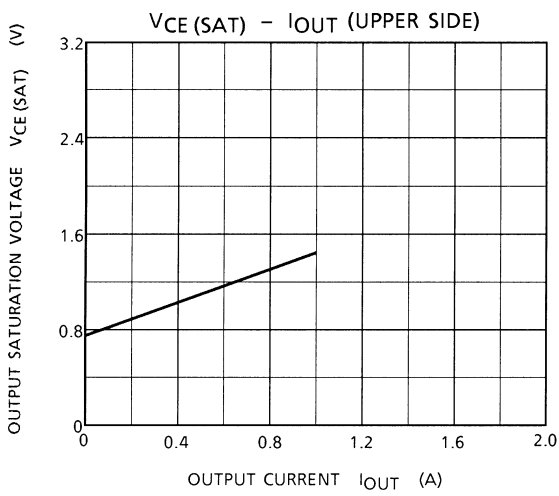
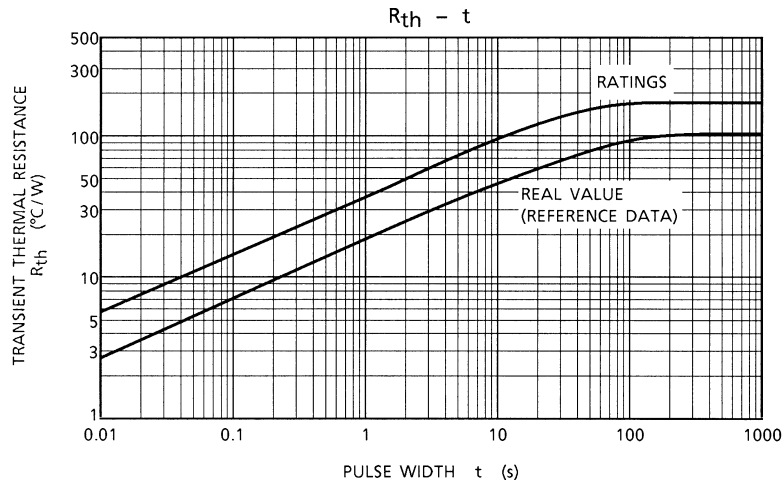

OUTLINE DRAWING

SIP9-P-2.54A

Unit: mm

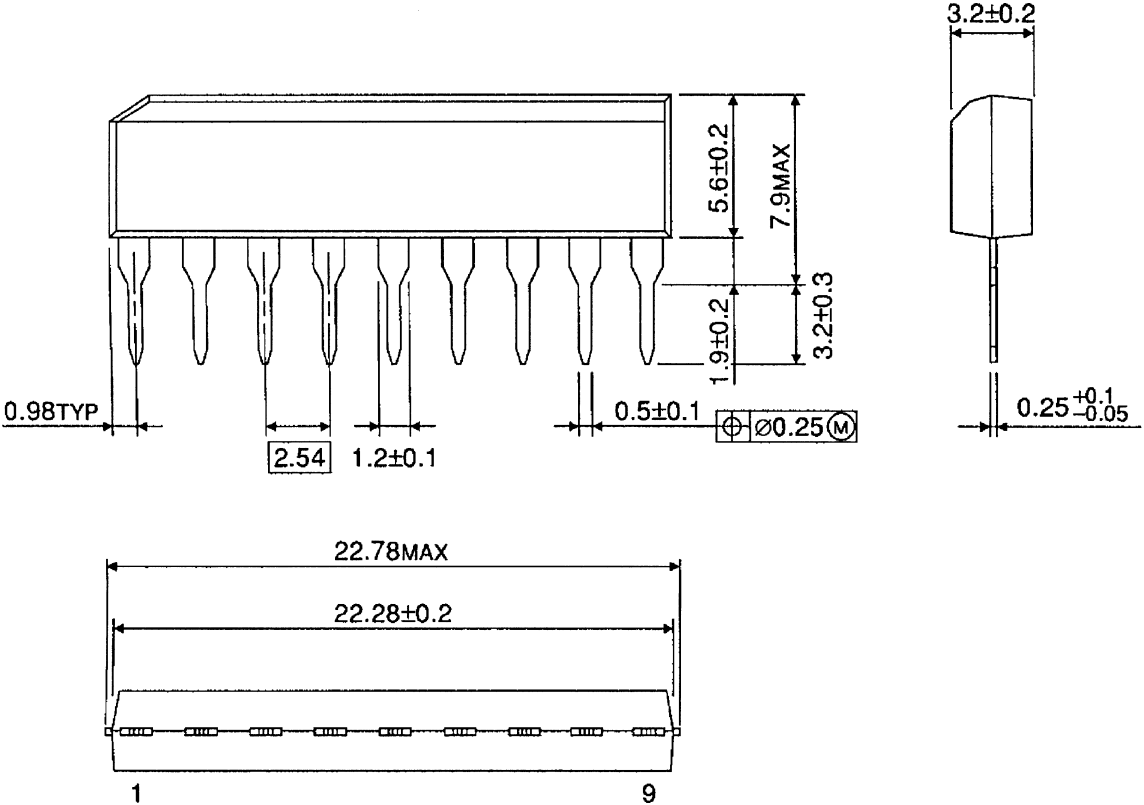

Weight: 0.92 g (Typ.)