

DESCRIPTION

These low capacitance diode arrays with common cathode are multiple, discrete, isolated junctions fabricated by a planar process and mounted in a 10-PIN package for use as steering diodes protecting up to eight I/O ports from ESD, EFT, or surge by directing them to the positive side of the power supply line (see figure 1). This circuit application is further complimented by the 1N6507 (separate data sheet) that has a common anode. An external TVS diode may be added between the positive supply line and ground to prevent overvoltage on the supply rail. They may also be used in fast switching core-driver applications. This includes computers and peripheral equipment such as magnetic cores, thin-film memories, plated-wire memories, etc., as well as decoding or encoding applications. These arrays offer many advantages of integrated circuits such as high-density packaging and improved reliability. This is a result of fewer pick and place operations, smaller footprint, smaller weight, and elimination of various discrete packages that may not be as user friendly in PC board mounting.

IMPORTANT: For the most current data, consult MICROSEMI's website: <http://www.microsemi.com>

APPEARANCE

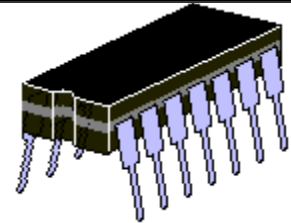

14-PIN Ceramic DIP

FEATURES

- Hermetic Ceramic Package
- Isolated Diodes to Eliminate Cross-Talk Voltages
- High Breakdown Voltage $V_{BR} > 60$ V at 10 μ A
- Low Leakage $I_R < 100$ nA at 40 V
- Low Capacitance $C < 4.0$ pF
- Switching Speeds less than 20 ns
- Options for screening in accordance with MIL-PRF-19500/474 for JAN, JANTX, JANTXV, and JANS are available by adding MQ, MX, MV, or MSP prefixes respectively to part numbers. For example, designate MX1N6506 for a JANTX screen.

MAXIMUM RATINGS

- V_{BR} Reverse Breakdown Voltage 60 V min (Note 1 & 2)
- I_O Continuous Forward Current of 300 mA (Note 1 & 3)
- I_{FSM} Forward Surge Current ($t_p=1/120$ s) 500 mA (Note 1)
- 400 mW Power Dissipation per Junction @ 25°C
- 600 mW Power Dissipation per Package @ 25°C (Note 4)
- Operating Junction Temperature range -65 to +150°C
- Storage Temperature range of -65 to +200°C

NOTE 1: Each Diode

NOTE 2: Pulsed: $P_w = 100$ ms max; duty cycle $\leq 20\%$

NOTE 3: Derate at 2.4 mA/°C above +25°C

NOTE 4: Derate at 4.0 mW/°C above +25°C

APPLICATIONS / BENEFITS

- High Frequency Data Lines
- RS-232 & RS-422 Interface Networks
- Ethernet: 10 Base T
- Computer I/O Ports
- LAN
- Switching Core Drivers
- IEC 61000-4 Compatible (see circuit in figure 1)
61000-4-2 ESD: Air 15 kV, contact 8 kW
61000-4-4 (EFT): 40 A – 5/50 ns
61000-4-5 (surge): 12 A 8/20 μ s

MECHANICAL AND PACKAGING

- 14-PIN Ceramic DIP
- Weight 2.05 grams (approximate)
- Marking: Logo, part number, date code
- Pin #1 to the left of the indent on top of package
- Carrier Tubes; 25 pcs (standard)

ELECTRICAL CHARACTERISTICS (Per Diode) @ 25°C unless otherwise specified

| PART NUMBER | FORWARD VOLTAGE V_{F1} $I_F = 100$ mA (Note 1) | FORWARD VOLTAGE V_{F2} $I_F = 500$ mA (Note 1) | REVERSE CURRENT I_{R1} $V_R = 40$ V | CAPACITANCE (PIN TO PIN) C_t $V_R = 0$ V $F = 1$ MHz | FORWARD RECOVERY TIME t_{fr} $I_F = 500$ mA | REVERSE RECOVERY TIME t_{rr} $I_F = I_R = 200$ mA $i_{rr} = 20$ mA $R_L = 100$ ohms |
|---------------|---|---|---|---|---|---|
| | V | V | μ A | pF | ns | ns |
| 1N6506 | 1 | 1.5 | 0.1 | 4.0 | 40 | 20 |

NOTE 1: Pulsed: $P_w = 300$ μ s +/- 50 μ s, duty cycle $\leq 2\%$, 90 μ s after leading edge.

SYMBOLS & DEFINITIONS

| Symbol | DEFINITION |
|-----------|---|
| V_{BR} | Minimum Breakdown Voltage: The minimum voltage the device will exhibit at a specified current |
| V_F | Maximum Forward Voltage: The maximum forward voltage the device will exhibit at a specified current |
| I_R | Maximum Leakage Current: The maximum leakage current that will flow at the specified voltage and temperature |
| I_{FSM} | Forward Surge Current: The peak forward surge current at a specified pulse width |
| C_t | Capacitance: The capacitance of the TVS as defined @ 0 volts at a frequency of 1 MHz and stated in picofarads |

SCHEMATIC

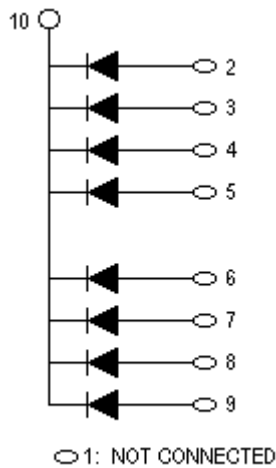

PACKAGE DIMENSIONS

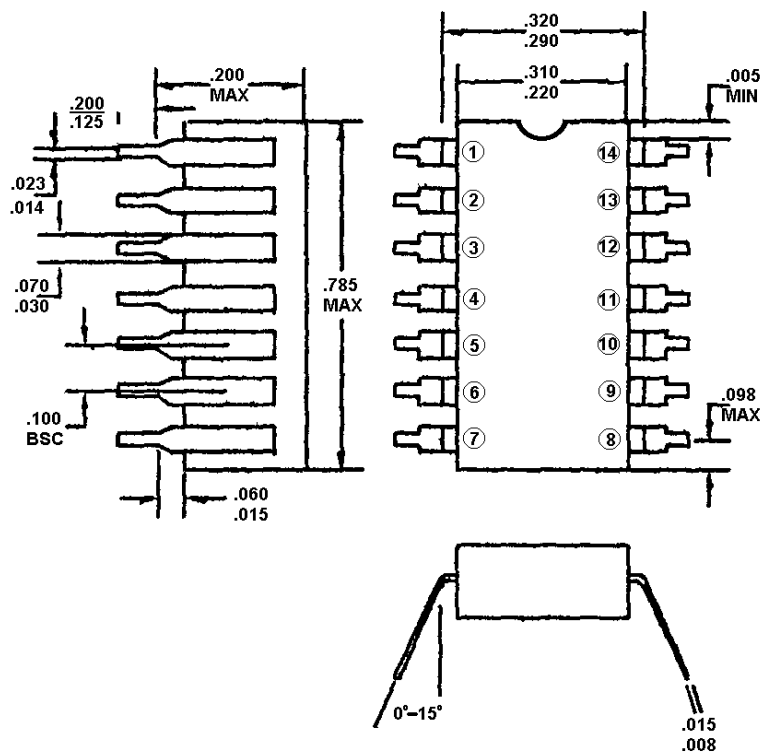

CIRCUIT

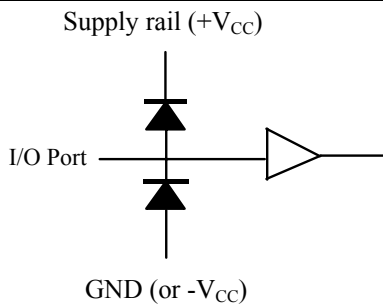

Steering Diode Application

FIGURE 1



LittleDiode supplies new, hard to find or obsolete electronic components and semiconductors all over the world.

With over two million different components listed you are sure to find the part you need.

Feel free to visit us today at our online store:

LittleDiode.com

Looking forward to providing you with the best possible service.