

### Features

- Low Forward Voltage Drop
- Guard Ring Construction for Transient Protection
- Fast Switching Speed
- Low Capacitance
- Surface Mount Package Ideally Suited for Automatic Insertion
- Also Available in Lead Free Version

### Mechanical Data

- Case: SOD-323, Plastic
- Case material - UL Flammability Rating Classification 94V-0
- Moisture sensitivity: Level 1 per J-STD-020A
- Terminals: Solderable per MIL-STD-202, Method 208
- Also Available in Lead Free Plating (Matte Tin Finish). Please see Ordering Information, Note 4, on Page 1
- Polarity: Cathode Band
- Marking: SA
- Weight: 0.004 grams (approx.)

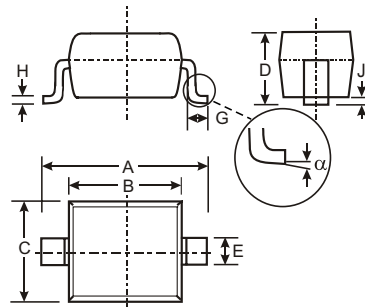

SOD-323		
Dim	Min	Max
A	2.30	2.70
B	1.60	1.80
C	1.20	1.40
D	1.05 Typical	
E	0.25	0.35
G	0.20	0.40
H	0.10	0.15
J	0.05 Typical	
$\alpha$	0°	8°
All Dimensions in mm		

### Maximum Ratings @ $T_A = 25^\circ\text{C}$ unless otherwise specified

Characteristic	Symbol	Value	Unit
Peak Repetitive Reverse Voltage Working Peak Reverse Voltage DC Blocking Voltage	$V_{RRM}$ $V_{RWM}$ $V_R$	70	V
RMS Reverse Voltage	$V_{R(RMS)}$	49	V
Forward Continuous Current	$I_{FM}$	15	mA
Power Dissipation (Note 1)	$P_D$	150	mW
Thermal Resistance, Junction to Ambient Air (Note 1)	$R_{\theta JA}$	650	$^\circ\text{C}/\text{W}$
Operating Temperature Range	$T_j$	-55 to +125	$^\circ\text{C}$
Storage Temperature Range	$T_{STG}$	-55 to +150	$^\circ\text{C}$

### Electrical Characteristics @ $T_A = 25^\circ\text{C}$ unless otherwise specified

Characteristic	Symbol	Min	Typ	Max	Unit	Test Condition
Reverse Breakdown Voltage (Note 2)	$V_{(BR)R}$	70	—	—	V	$I_R = 10\mu\text{A}$
Reverse Leakage Current (Note 2)	$I_R$	—	—	200	nA	$V_R = 50\text{V}$
Forward Voltage Drop	$V_F$	—	—	0.41 1.00	V	$I_F = 1.0\text{mA}$ $I_F = 15\text{mA}$
Total Capacitance	$C_T$	—	—	2.0	pF	$V_R = 0\text{V}$ , $f = 1.0\text{MHz}$
Reverse Recovery Time	$t_{rr}$	—	—	1.0	ns	$I_F = I_R = 5.0\text{mA}$ $I_{rr} = 0.1 \times I_R$ , $R_L = 100\Omega$

### Ordering Information (Note 3)

Device	Packaging	Shipping
1N5711WS-7	SOD-323	3000/Tape and Reel

- Note:
1. Part mounted on FR-4 PC board with recommended pad layout, which can be found on our website at <http://www.diodes.com/datasheets/ap02001.pdf>.
  2. Short duration test pulse used to minimize self-heating effect.
  3. For Packaging Details, go to our website at <http://www.diodes.com/datasheets/ap02007.pdf>.
  4. For Lead Free version (with Lead Free terminal finish) part number, please add "-F" suffix to part number above.  
Example: 1N5711WS-7-F.

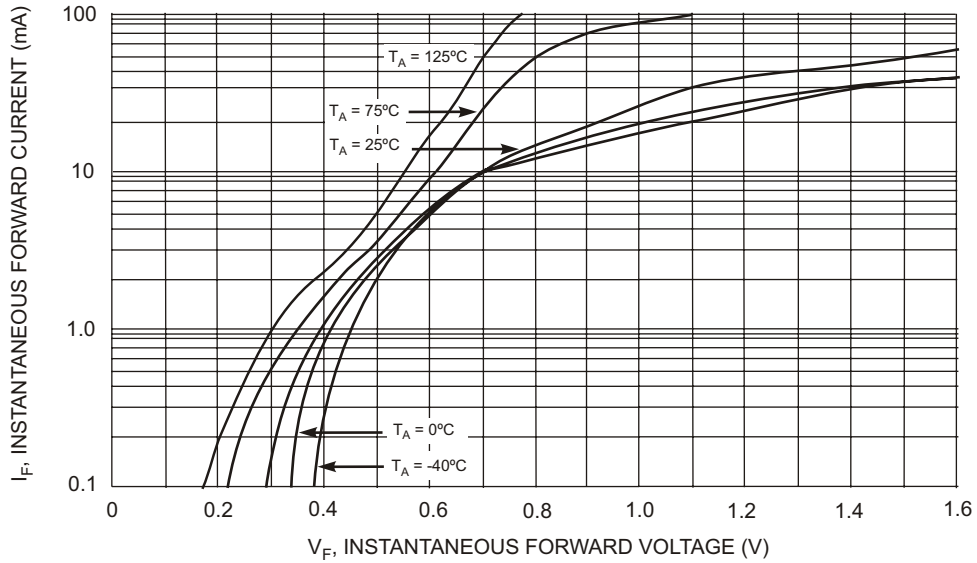

Fig. 1 Typical Forward Characteristics

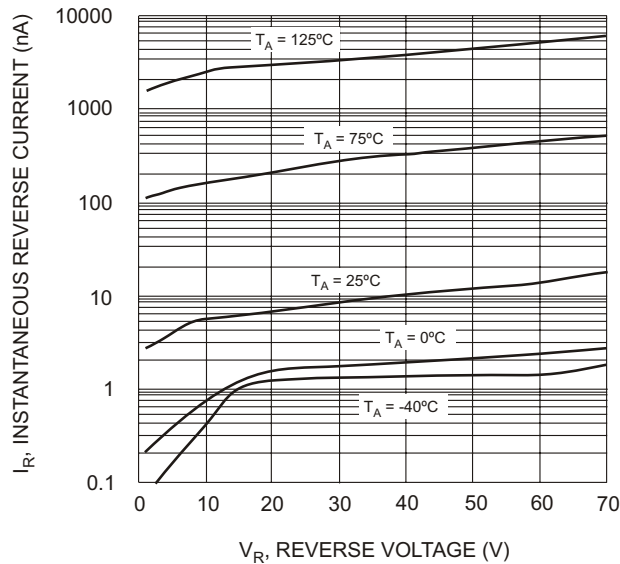

Fig. 2 Typical Reverse Characteristics

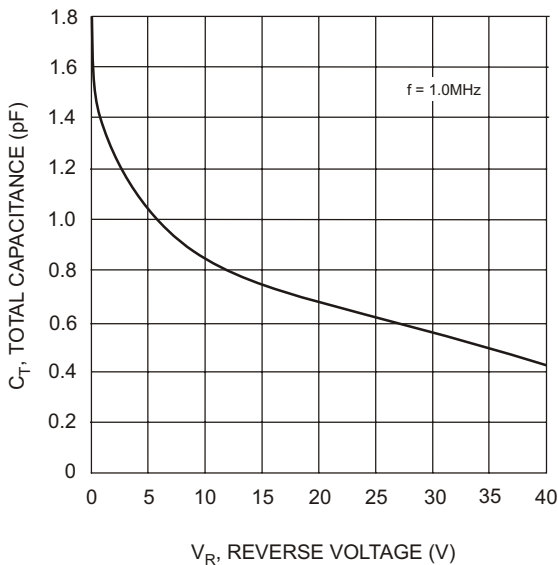

Fig. 3 Typical Capacitance

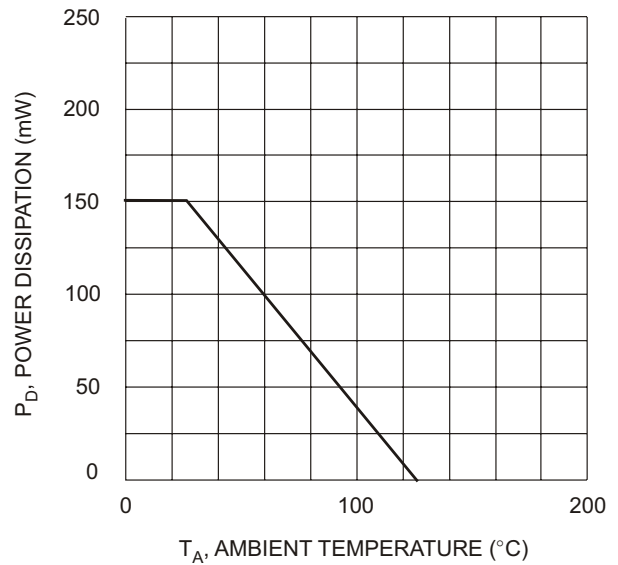
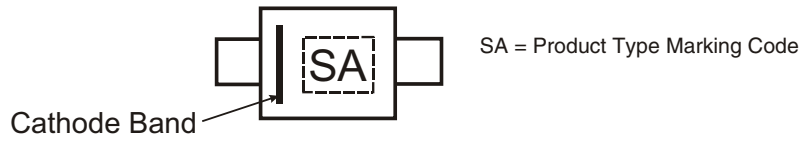

Fig. 4 Power Derating Curve

---

**Marking Information**

---





LittleDiode supplies new, hard to find or obsolete electronic components and semiconductors all over the world.

With over two million different components listed you are sure to find the part you need.

Feel free to visit us today at our online store:

[LittleDiode.com](http://LittleDiode.com)

Looking forward to providing you with the best possible service.