

## 1N4728A-G Thru. Z1330A-G

Zener Voltage: 3.3 to 330 Volts

DC Power: 1 Watts

RoHS Device



### Features

- Glass passivated chip.
- Low leakage.
- Built-in strain relief.
- Low inductance.
- High peak reverse power dissipation.
- For use in stabilizing and clipping with high power rating.

### Mechanical data

- Case: Molded plastic.
- Epoxy: UL 94V-0 rate flame retardant.
- Terminals: Solderable per MIL-STD-202, method 208 guaranteed.
- Polarity: Color band denotes cathode end.
- Mounting position: Any.
- Approx. weight: 0.35 grams(approx.).

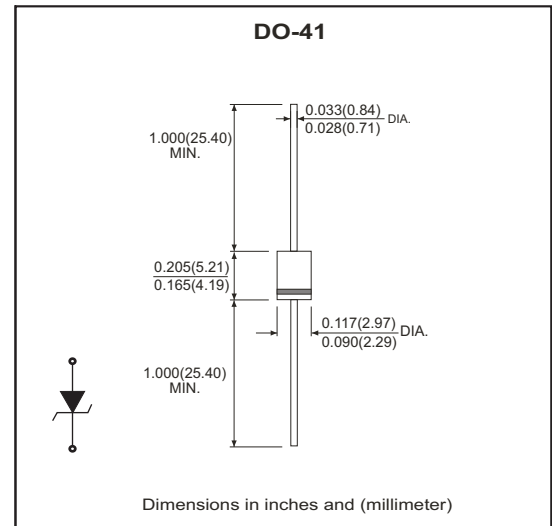

### Maximum Ratings and Electrical Characteristics

Ratings at 25°C ambient temperature unless otherwise specified.  
Single phase, half wave, 60Hz, resistive or inductive load.  
For capacitive load, derate current by 20%.

Characteristics	Symbol	Value	Units
DC power dissipation at $T_L=50^\circ\text{C}$ (Note 1)	$P_D$	1	W
Maximum forward voltage at $I_F=200\text{ mA}$	$V_F$	1.2	V
Maximum thermal resistance junction to ambient air (Note 2)	$R_{\theta JA}$	170	K/W
Junction temperature range	$T_J$	-55 to +175	$^\circ\text{C}$
Storage temperature range	$T_{STG}$	-55 to +175	$^\circ\text{C}$

Notes:

1.  $T_L$ = Lead temperature at 3/8" (9.5mm) from body.
2. Valid provided that leads are kept at ambient temperature at a distance of 10mm from case.

## Electrical Characteristics (1N4728A-G Thru. Z1330A-G)

Part No	Nominal Zener Voltage		Maximum Zener Impedance			Maximum Reverse Leakage Current		Maximum DC Zener Current	Maximum Surge Current	Marking Code
	V <sub>Z</sub> @I <sub>ZT</sub>	I <sub>ZT</sub>	Z <sub>ZT</sub> @I <sub>ZT</sub>	Z <sub>ZK</sub> @I <sub>ZK</sub>	I <sub>ZK</sub>	I <sub>R</sub> @V <sub>R</sub>		I <sub>ZM</sub>	I <sub>RM</sub>	
	(V)	(mA)	(Ω)	(Ω)	(mA)	(μA)	(V)	(mA)	(mApk)	
1N4728A-G	3.3	76.00	10	400	1.00	100	1.0	274.00	1370	1N4728A
1N4729A-G	3.6	69.00	10	400	1.00	100	1.0	251.00	1255	1N4729A
1N4730A-G	3.9	64.00	9.0	400	1.00	50	1.0	232.00	1160	1N4730A
1N4731A-G	4.3	58.00	9.0	400	1.00	10	1.0	210.00	1050	1N4731A
1N4732A-G	4.7	53.00	8.0	500	1.00	10	1.0	192.00	960	1N4732A
1N4733A-G	5.1	49.00	7.0	550	1.00	10	1.0	177.00	885	1N4733A
1N4734A-G	5.6	45.00	5.0	600	1.00	10	2.0	161.00	805	1N4734A
1N4735A-G	6.2	41.00	2.0	700	1.00	10	3.0	146.00	730	1N4735A
1N4736A-G	6.8	37.00	3.5	700	1.00	5.0	4.0	133.00	660	1N4736A
1N4737A-G	7.5	34.00	4.0	700	0.50	5.0	5.0	121.00	605	1N4737A
1N4738A-G	8.2	31.00	4.5	700	0.50	5.0	6.0	110.00	550	1N4738A
1N4739A-G	9.1	28.00	5.0	700	0.50	0.5	7.0	100.00	500	1N4739A
1N4740A-G	10.0	25.00	7.0	700	0.25	0.5	7.6	91.00	454	1N4740A
1N4741A-G	11.0	23.00	8.0	700	0.25	0.1	8.4	83.00	414	1N4741A
1N4742A-G	12.0	21.00	9.0	700	0.25	0.1	9.1	76.00	380	1N4742A
1N4743A-G	13.0	19.00	10.0	700	0.25	0.1	9.9	69.00	344	1N4743A
1N4744A-G	15.0	17.00	14.0	700	0.25	0.1	11.4	61.00	305	1N4744A
1N4745A-G	16.0	15.50	16.0	700	0.25	0.1	12.2	57.00	285	1N4745A
1N4746A-G	18.0	14.00	20.0	750	0.25	0.1	13.7	50.00	250	1N4746A
1N4747A-G	20.0	12.50	22.0	750	0.25	0.1	15.2	45.00	225	1N4747A
1N4748A-G	22.0	11.50	23.0	750	0.25	0.1	16.7	41.00	205	1N4748A
1N4749A-G	24.0	10.50	25.0	750	0.25	0.1	18.2	38.00	190	1N4749A
1N4750A-G	27.0	9.50	35.0	750	0.25	0.1	20.6	34.00	170	1N4750A
1N4751A-G	30.0	8.50	40.0	1000	0.25	0.1	22.8	30.00	150	1N4751A
1N4752A-G	33.0	7.50	45.0	1000	0.25	0.1	25.1	27.00	135	1N4752A
1N4753A-G	36.0	7.00	50.0	1000	0.25	0.1	27.4	25.00	125	1N4753A
1N4754A-G	39.0	6.50	60.0	1000	0.25	0.1	29.7	23.00	115	1N4754A
1N4755A-G	43.0	6.00	70.0	1500	0.25	0.1	32.7	22.00	110	1N4755A
1N4756A-G	47.0	5.50	80.0	1500	0.25	0.1	35.8	19.00	95	1N4756A
1N4757A-G	51.0	5.00	95.0	1500	0.25	0.1	38.8	18.00	90	1N4757A
1N4758A-G	56.0	4.50	110.0	2000	0.25	0.1	42.6	16.00	80	1N4758A
1N4759A-G	62.0	4.00	125.0	2000	0.25	0.1	47.1	14.00	70	1N4759A
1N4760A-G	68.0	3.70	150.0	2000	0.25	0.1	51.7	13.00	65	1N4760A
1N4761A-G	75.0	3.30	175.0	2000	0.25	0.1	56.0	12.00	60	1N4761A
1N4762A-G	82.0	3.00	200.0	3000	0.25	0.1	62.2	11.00	55	1N4762A
1N4763A-G	91.0	2.80	250.0	3000	0.25	0.1	69.2	10.00	50	1N4763A
1N4764A-G	100.0	2.50	350.0	3000	0.25	0.1	76.0	9.00	45	1N4764A

Notes:

1. The type number listed have a standard tolerance on the nominal zener voltage of  $\pm 5\%$ .
2. The reverse surge current is a non-repetitive, 8.3ms pulse width square wave or equivalent sine-wave superimposed on I<sub>ZT</sub> per JEDEC method.

Company reserves the right to improve product design , functions and reliability without notice.

REV:B

# Axial Lead Zener Diode

## Electrical Characteristics (1N4728A-G Thru. Z1330A-G)

Part No	Nominal Zener Voltage		Maximum Zener Impedance			Maximum Reverse Leakage Current		Maximum DC Zener Current	Maximum Surge Current	Marking Code
	V <sub>Z</sub> @I <sub>ZT</sub>	I <sub>ZT</sub>	Z <sub>ZT</sub> @I <sub>ZT</sub>	Z <sub>ZK</sub> @I <sub>ZK</sub>	I <sub>ZK</sub>	I <sub>R</sub> @V <sub>R</sub>		I <sub>ZM</sub>	I <sub>RM</sub>	
	(V)	(mA)	(Ω)	(Ω)	(mA)	(μA)	(V)	(mA)	(mApk)	
Z1110A-G	110.0	2.30	450.0	4000	0.25	0.1	83.6	8.60	40	Z1110A
Z1120A-G	120.0	2.00	550.0	4500	0.25	0.1	91.2	7.80	37	Z1120A
Z1130A-G	130.0	1.90	700.0	5000	0.25	0.1	98.8	7.00	34	Z1130A
Z1150A-G	150.0	1.70	1000.0	6000	0.25	0.1	114.0	6.40	30	Z1150A
Z1160A-G	160.0	1.60	1100.0	6500	0.25	0.1	121.6	5.80	28	Z1160A
Z1180A-G	180.0	1.40	1200.0	7000	0.25	0.1	136.8	5.20	25	Z1180A
Z1200A-G	200.0	1.20	1900.0	9990	0.25	0.1	152.0	4.70	22	Z1200A
Z1220A-G	220.0	1.10	1600.0	8000	0.25	0.1	167.2	4.00	20	Z1220A
Z1240A-G	240.0	0.90	1800.0	8500	0.25	0.1	182.4	3.80	19	Z1240A
Z1250A-G	250.0	0.90	2000.0	9000	0.25	0.1	190.0	3.60	18	Z1250A
Z1270A-G	270.0	0.80	2100.0	9000	0.25	0.1	205.0	3.30	16	Z1270A
Z1300A-G	300.0	0.80	2300.0	9500	0.25	0.1	228.0	3.00	15	Z1300A
Z1330A-G	330.0	0.70	2500.0	9500	0.25	0.1	250.0	2.70	13	Z1330A

Notes:

1. The type number listed have a standard tolerance on the nominal zener voltage of  $\pm 5\%$ .
2. The reverse surge current is a non-repetitive, 8.3ms pulse width square wave or equivalent sine-wave superimposed on I<sub>ZT</sub> per JEDEC method.

## RATING AND CHARACTERISTIC CURVES (1N4728A-G Thru. Z1330A-G)

Fig.1 - Power Temperature Derating Curve

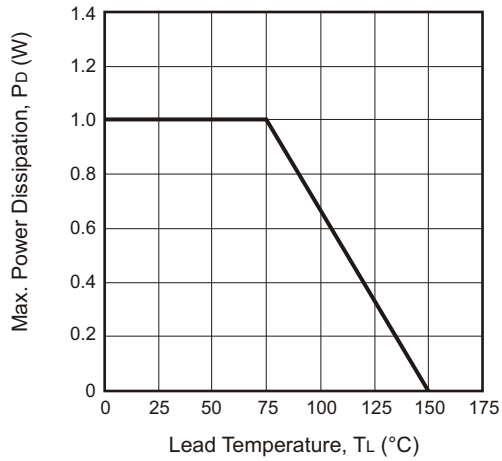

Fig.2 - Temperature Coefficients v.s. Zener Voltage

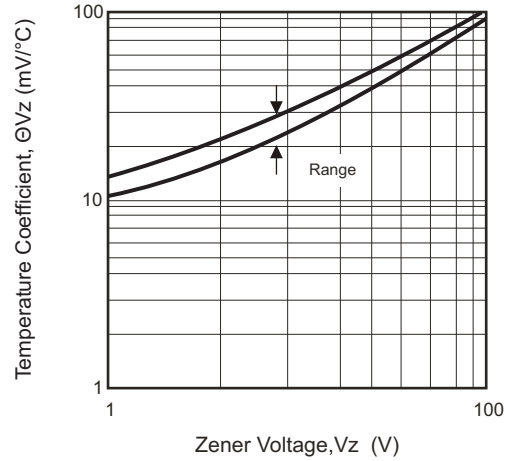

Fig.3 - Typical Thermal Resistance v.s. Lead Length

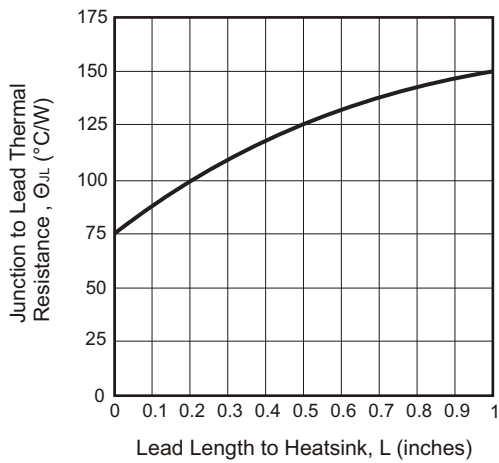
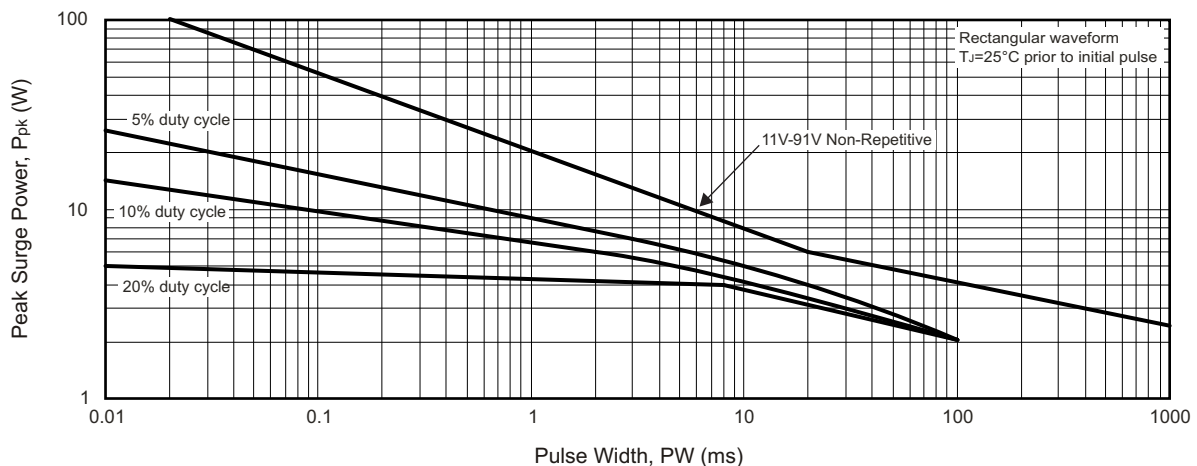

Fig.4 - Maximum Surge Power



Company reserves the right to improve product design, functions and reliability without notice.

REV:B

## Taping Specification For Axial Lead Diodes

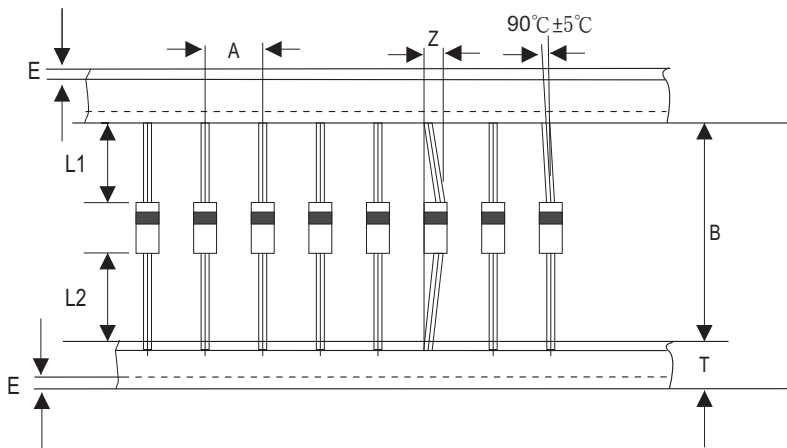

DO-41	SYMBOL	A	B	Z	T	E	L1-L2
	(mm)	5.00 ± 0.5	52.0 ± 0.5	1.2 (max)	6.0 ± 0.4	3 (max)	1.0 (max)
	(inch)	0.197 ± 0.020	2.047 ± 0.020	0.047 (max)	0.236 ± 0.016	0.118 (max)	0.039 (max)

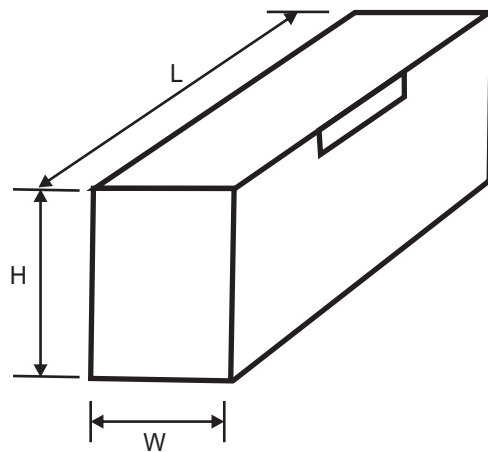

## Standard Packaging

Case Type	AMMO PACK	
	BOX ( pcs )	CARTON ( pcs )
DO-41	5,000	50,000



LittleDiode supplies new, hard to find or obsolete electronic components and semiconductors all over the world.

With over two million different components listed you are sure to find the part you need.

Feel free to visit us today at our online store:

[LittleDiode.com](http://LittleDiode.com)

Looking forward to providing you with the best possible service.