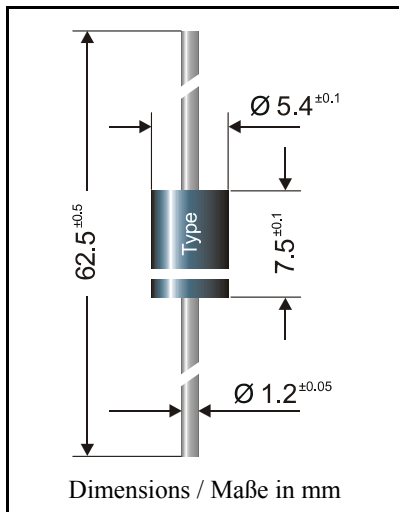

Silicon Rectifiers
Silizium Gleichrichter

Nominal current – Nennstrom	5 A
Repetitive peak reverse voltage Periodische Spitzensperrspannung	50...1000 V
Plastic case Kunststoffgehäuse	Ø 5.4 x 7.5 [mm]
Weight approx. – Gewicht ca.	1.4 g
Plastic material has UL classification 94V-0 Gehäusematerial UL94V-0 klassifiziert	
Standard packaging taped in ammo pack Standard Lieferform gegurtet in Ammo-Pack	see page 16 siehe Seite 16

Maximum ratings
Grenzwerte

Type Typ	Repetitive peak reverse voltage Periodische Spitzensperrspannung V_{RRM} [V]	Surge peak reverse voltage Stoßspitzensperrspannung V_{RSM} [V]
BY 550-50	50	50
BY 550-100	100	100
BY 550-200	200	200
BY 550-400	400	400
BY 550-600	600	600
BY 550-800	800	800
BY 550-1000	1000	1000

Max. average forward rectified current, R-load Dauergrenzstrom in Einwertschaltung mit R-Last	$T_A = 50^\circ\text{C}$	I_{FAV}	5 A ¹⁾
Repetitive peak forward current Periodischer Spitzenstrom	$f > 15\text{ Hz}$	I_{FRM}	60 A ¹⁾
Peak forward surge current, 50 Hz half sine-wave Stoßstrom für eine 50 Hz Sinus-Halbwellen	$T_A = 25^\circ\text{C}$	I_{FSM}	300 A
Rating for fusing – Grenzlastintegral, $t < 10\text{ ms}$	$T_A = 25^\circ\text{C}$	i^2t	450 A ² s
Operating junction temperature – Sperrschichttemperatur		T_j	- 50...+175°C
Storage temperature – Lagerungstemperatur		T_s	- 50...+175°C

¹⁾ Valid, if leads are kept at ambient temperature at a distance of 10 mm from case

Gültig, wenn die Anschlußdrähte in 10 mm Abstand von Gehäuse auf Umgebungstemperatur gehalten werden

Characteristics

Kennwerte

Forward voltage – Durchlaßspannung	$T_j = 25^\circ\text{C}$	$I_F = 5\text{ A}$	V_F	< 1.0 V
Leakage current – Sperrstrom	$T_j = 25^\circ\text{C}$	$V_R = V_{RRM}$	I_R	< 20 μA
Thermal resistance junction to ambient air Wärmewiderstand Sperrschicht – umgebende Luft			R_{thA}	< 25 K/W ¹⁾

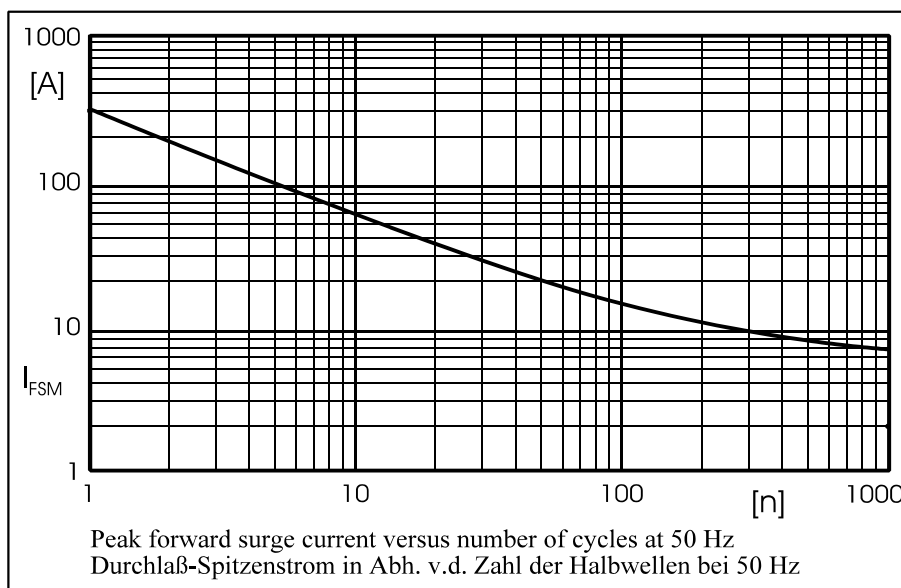
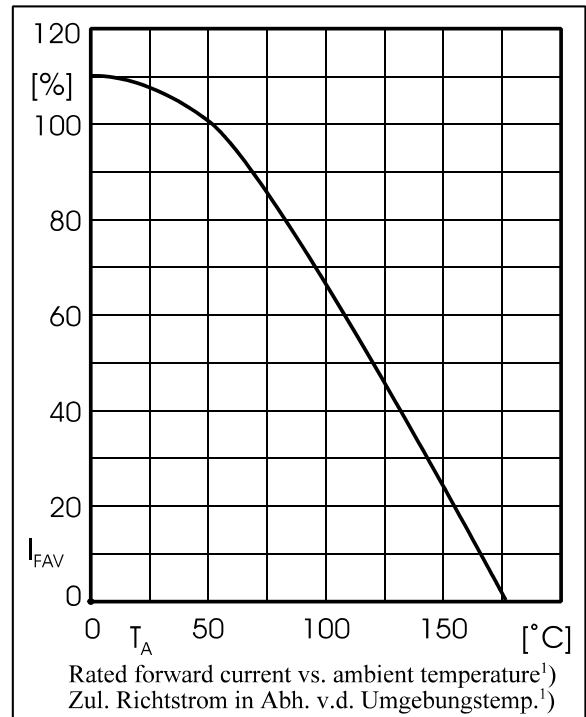
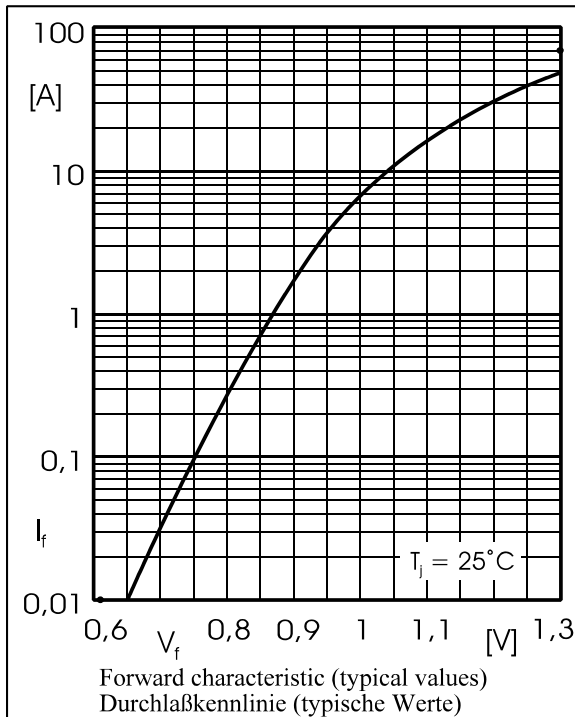

¹⁾ Valid, if leads are kept at ambient temperature at a distance of 10 mm from case
Gültig, wenn die Anschlußdrähte in 10 mm Abstand von Gehäuse auf Umgebungstemperatur gehalten werden

This datasheet has been downloaded from:

www.DatasheetCatalog.com

Datasheets for electronic components.



LittleDiode supplies new, hard to find or obsolete electronic components and semiconductors all over the world.

With over two million different components listed you are sure to find the part you need.

Feel free to visit us today at our online store:

LittleDiode.com

Looking forward to providing you with the best possible service.