

T-33-19

PNP Silicon Epibase Transistors

SIEMENS AKTIENGESELLSCHAFT 368 D

BD 434
 BD 436
 BD 438
 BD 440
 BD 442

Power transistors for complementary AF stages

The transistors BD 434, BD 436, BD 438, BD 440 and BD 442 are PNP silicon epibase power transistors in a TO 126 plastic package (12 A 3 DIN 41869, sheet 4). The collector is electrically connected to the metallic mounting area. The transistors are particularly suitable for use in push-pull output stages, driver stages and for general AF applications. Their complementary types are the NPN transistors BD 433, BD 435, BD 437, BD 439, and BD 441.

Type	Ordering code
BD 434	Q62702-D202
BD 434/BD 433 paired	Q62702-D217
BD 436	Q62702-D204
BD 436/BD 435 paired	Q62702-D218
BD 438	Q62702-D213
BD 438/BD 437 paired	Q62702-D219
BD 440	Q62702-D281
BD 440/BD 439 paired	Q62702-D284
Bd 442	Q62702-D283
BD 442/BD 441 paired	Q62702-D285
Mica washer	Q62902-B62
Spring washer A3 DIN137	Q62902-B63

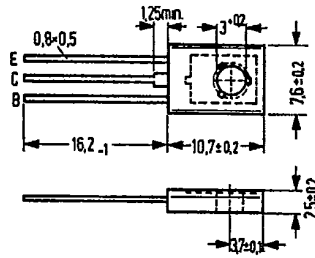

Approx. weight 0.5 g Dimensions in mm
 Transistor fixing with M 3 screw. Starting torque max. 0.8 Nm; washer or spring washer should be used.
 1) If a 60 μ mica washer (ungreased) is used, the thermal resistance increases by 8 K/W and in case of a greased one by 4 K/W.

Maximum ratings		BD 434	BD 436	BD 438	BD 440	BD 442	
Collector-emitter voltage	$-V_{CEO}$	22	32	45	60	80	V
Collector-emitter voltage	$-V_{CES}$	22	32	45	60	80	V
Collector-base voltage	$-V_{CBO}$	22	32	45	60	80	V
Emitter-base voltage	$-V_{EBO}$	5	5	5	5	5	V
Collector current	$-I_C$	4	4	4	4	4	A
Collector peak current ($t < 10$ ms)	$-I_{CM}$	7	7	7	7	7	A
Emitter peak current ($t < 10$ ms)	$-I_{EM}$	7	7	7	7	7	A
Base current	$-I_B$	1	1	1	1	1	A
Junction temperature	T_j	150	150	150	150	150	°C
Storage temperature range	T_{stg}	-55 to +150					°C
Total power dissipation ($T_{case} \leq 25^\circ\text{C}; V_{CE} \leq 12$ V)	P_{tot}	36	36	36	36	36	W
Thermal resistance							
Junction to ambient air	R_{thJA}	≤ 100	≤ 100	≤ 100	≤ 100	≤ 100	K/W
Junction to mounting area	$R_{thJC}^{1)}$	$\leq 3,5$	$\leq 3,5$	$\leq 3,5$	$\leq 3,5$	$\leq 3,5$	K/W

Static characteristics ($T_{case} = 25^{\circ}C$)

		BD 434	BD 436	BD 438	BD 440	BD 442	
Collector-emitter breakdown voltage ($-I_C = 100\text{ mA}$)	$-V_{(BR)CEO}$	>22	>32	>45	>60	>80	V
Collector-emitter breakdown voltage ($-I_C = 100\ \mu\text{A}$)	$-V_{(BR)CES}$	>22	>32	>45	>60	>80	V
Collector-base breakdown voltage ($-I_C = 100\ \mu\text{A}$)	$-V_{(BR)CBO}$	>22	>32	>45	>60	>80	V
Emitter-base breakdown voltage ($I_E = 1\text{ mA}$)	$-V_{(BR)EBO}$	>5	>5	>5	>5	>5	
Collector cutoff current ($-V_{CB} = 22\text{ V}$)	$-I_{CBO}$	<100	-	-	-	-	μA
Collector cutoff current ($-V_{CB} = 32\text{ V}$)	$-I_{CBO}$	-	<100	-	-	-	μA
Collector cutoff current ($-V_{CB} = 45\text{ V}$)	$-I_{CBO}$	-	-	<100	-	-	μA
Collector cutoff current ($-V_{CB} = 60\text{ V}$)	$-I_{CBO}$	-	-	-	<100	-	μA
Collector cutoff current ($-V_{CB} = 80\text{ V}$)	$-I_{CBO}$	-	-	-	-	<100	μA
Collector cutoff current ($-V_{CB} = 10\text{ V}; T_{amb} = 150^{\circ}C$)	$-I_{CBO}$	<1	<1	<1	<1	<1	mA
Collector cutoff current ($-V_{CB} = V_{CBmax}; T_{amb} = 150^{\circ}C$)	$-I_{CBO}$	<3	<3	<3	<3	<3	mA
Base-emitter forward voltage ($-I_C = 2\text{ A}; -V_{CE} = 1\text{ V}$)	$-V_{BE}$	<1.1	<1.1	<1.2	<1.5	<1.5	V
Base-emitter forward voltage ($-I_C = 3\text{ A}; -V_{CE} = 1\text{ V}$)	$-V_{BE}$	-	-	<1.3	<1.6	<1.6	V
Collector-emitter saturation voltage ($-I_C = 2\text{ A}$) ¹⁾	$-V_{CEsat}$	<0.8	<0.8	-	-	-	V
Collector-emitter saturation voltage ($-I_C = 2\text{ A}; -I_B = 0.2\text{ A}$)	$-V_{CEsat}$	<0.5	<0.5	<0.6	<0.8	<0.8	V
Collector-emitter saturation voltage ($-I_C = 3\text{ A}; -I_B = 0.3\text{ A}$)	$-V_{CEsat}$	-	-	<0.7	<0.9	<0.9	V
DC current gain ($-I_C = 10\text{ mA}; -V_{CE} = 5\text{ V}$)	h_{FE}	>40	>40	>30	>20	>15	-
($-I_C = 500\text{ mA}; -V_{CE} = 1\text{ V}$) ²⁾	h_{FE}	>85	>85	>85	>40	>40	-
($-I_C = 2\text{ A}; -V_{CE} = 1\text{ V}$)	h_{FE}	>50	>50	>40	>25	>15	-

1) For the characteristics which passes through the point $I_C = 2.2\text{ mA}$ and $V_{CE} = 1\text{ V}$ at constant base current.
2) Available as matching pairs with BD 433, BD 435, BD 437, BD 439, and BD 441. Condition for matching pairs $h_{FE1}/h_{FE2} \leq 1.41$.

SIEMENS AKTIENGESELLSCHAFT

Dynamic characteristics ($T_{case} = 25^{\circ}C$)

	BD 434	BD 436	BD 438	BD 440	BD 442	
Transition frequency ($-I_C = 0,25 A; -V_{CE} = 1 V;$ $f = 1 MHz$)	>3	>3	>3	>3	>3	MHz
Cutoff frequency in common emitter configuration ($-I_C = 0.25 A; -V_{CE} = 1 V$)	$f_{hfe} >20$	>20	>20	>20	>20	kHz

Total perm. power dissipation versus temperature

$P_{tot} = f(T_{case}); V_{CE} = 0 \text{ to } 12 V$
BD 434, BD 436, BD 438,
BD 440, BD 442

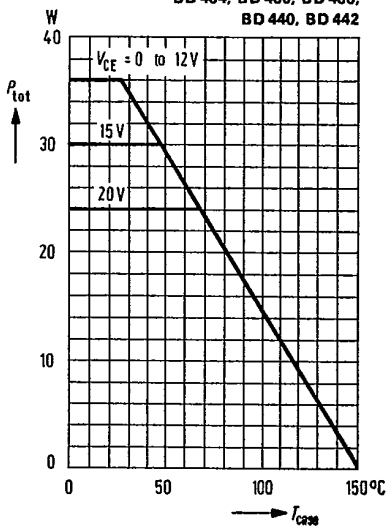

Permissible pulse load

$f_{thJC} = f(t); v = \text{parameter}$
BD 434, BD 436, BD 438,
BD 440, BD 442

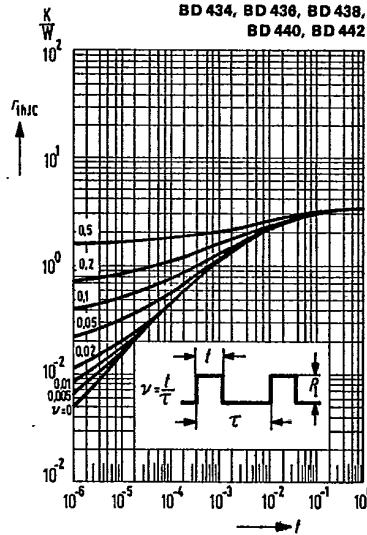

Permissible operating range

SIEMENS AKTIENGESELLSCHAFT; 04371 D

- BD 434
- BD 436
- BD 438
- BD 440
- BD 442

Permissible operating range
 $I_C = f(V_{CE}); T_{case} = 25^\circ C, v = 0$
 BD 434, BD 436, BD 438

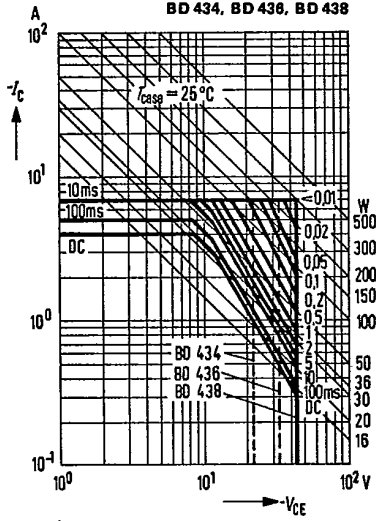

Permissible operating range
 $I_C = f(V_{CE}); T_{case} = 25^\circ C, v = 0$
 BD 440, BD 442

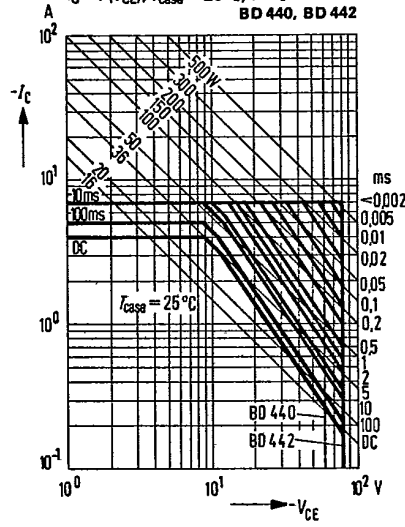

DC current gain $h_{FE} = f(I_C)$
 $V_{CE} = 1 V; T_{case} = \text{parameter}$
 BD 434, BD 436, BD 438,
 BD 440, BD 442

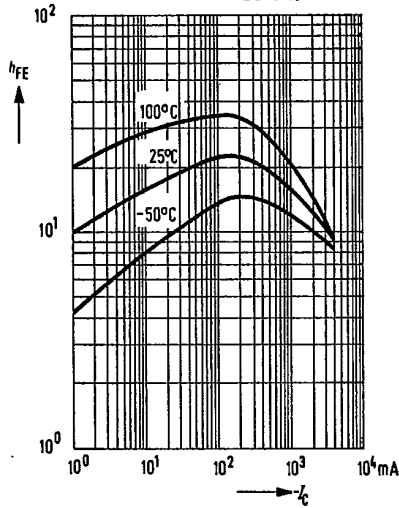

Collector cutoff current
 versus temperature $-I_{CBO} = f(T_{case})$
 $-V_{CB} = -V_{CBmax}$
 BD 434, BD 436, BD 438,
 BD 440, BD 442

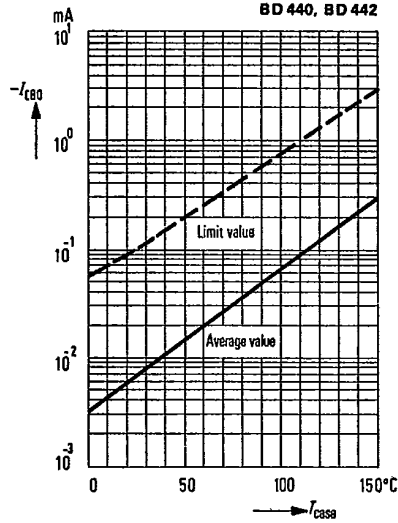

BD 434
BD 436
BD 438
BD 440
BD 442

SIEMENS AKTIENGESELLSCHAFT

Collector current $I_C = f(V_{BE})$
 $-V_{CE} = 2 \text{ V}; T_{\text{case}} = 25^\circ\text{C}$
 BD 434, BD 436, BD 438,
 BD 440, BD 442

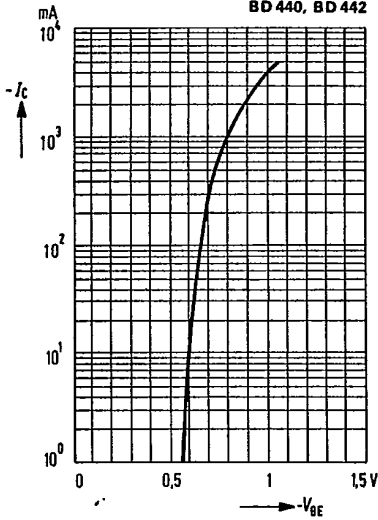

Collector-emitter saturation voltage
 $V_{CEsat} = f(I_C); h_{FE} = 10$
 BD 434, BD 436, BD 438,
 BD 440, BD 442

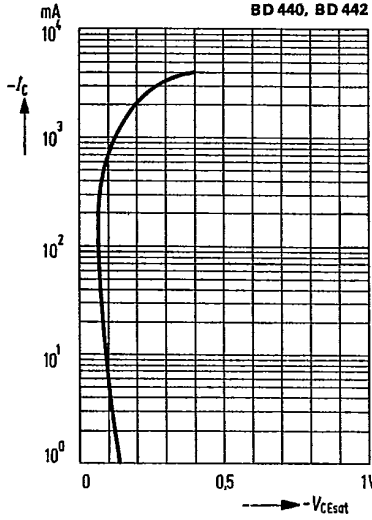

Output characteristics $I_C = f(V_{CE})$
 $I_B = \text{parameter}$
 (common emitter configuration)
 BD 434, BD 436, BD 438,
 BD 440, BD 442

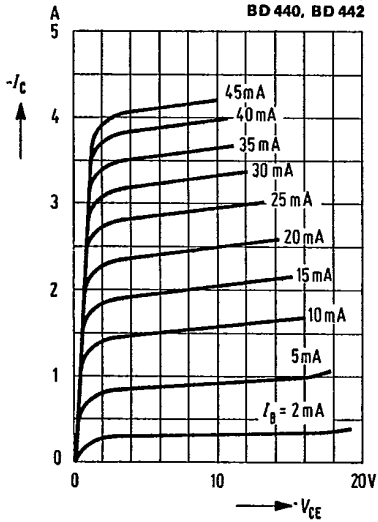

Transition frequency $f_T = f(I_C)$
 $T_{\text{case}} = 25^\circ\text{C}$
 BD 434, BD 436, BD 438,
 BD 440, BD 442

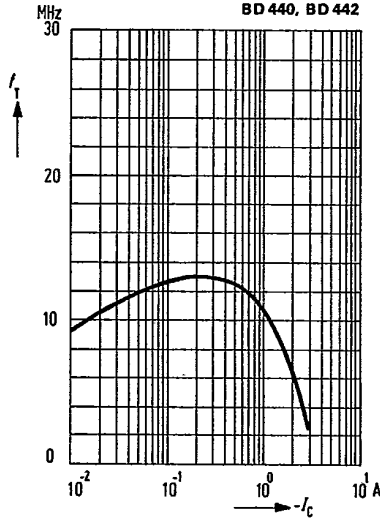



LittleDiode supplies new, hard to find or obsolete electronic components and semiconductors all over the world.

With over two million different components listed you are sure to find the part you need.

Feel free to visit us today at our online store:

LittleDiode.com

Looking forward to providing you with the best possible service.