

SILICON N-CHANNEL DUAL GATE MOS-FET

Depletion type field-effect transistor in a plastic X-package with source and substrate interconnected, intended for VHF applications, such as VHF television tuners, FM tuners, with 12 V supply voltage.

This MOS-FET tetrode is protected against excessive input voltage surges by integrated back-to-back diodes between gates and source.

QUICK REFERENCE DATA

Drain-source voltage	V_{DS}	max.	20 V
Drain current	I_D	max.	40 mA
Total power dissipation up to $T_{amb} = 75\text{ }^{\circ}\text{C}$	P_{tot}	max.	225 mW
Junction temperature	T_j	max.	150 $^{\circ}\text{C}$
Transfer admittance at $f = 1\text{ kHz}$ $I_D = 15\text{ mA}$; $V_{DS} = 10\text{ V}$; $+V_{G2-S} = 4\text{ V}$	$ Y_{fs} $	typ.	25 mS
Input capacitance at gate 1; $f = 1\text{ MHz}$ $I_D = 15\text{ mA}$; $V_{DS} = 10\text{ V}$; $+V_{G2-S} = 4\text{ V}$	C_{ig1-s}	typ.	4.0 pF
Feedback capacitance at $f = 1\text{ MHz}$ $I_D = 15\text{ mA}$; $V_{DS} = 10\text{ V}$; $+V_{G2-S} = 4\text{ V}$	C_{rs}	typ.	30 fF
Noise figure at $G_S = 2\text{ mS}$; $B_S = B_{S\text{ opt}}$ $I_D = 15\text{ mA}$; $V_{DS} = 10\text{ V}$; $+V_{G2-S} = 4\text{ V}$; $f = 200\text{ MHz}$	F	typ.	1.2 dB

MECHANICAL DATA

Dimensions in mm

Fig.1 SOT103.

Pinning

- 1 = source
- 2 = drain
- 3 = gate 2
- 4 = gate 1

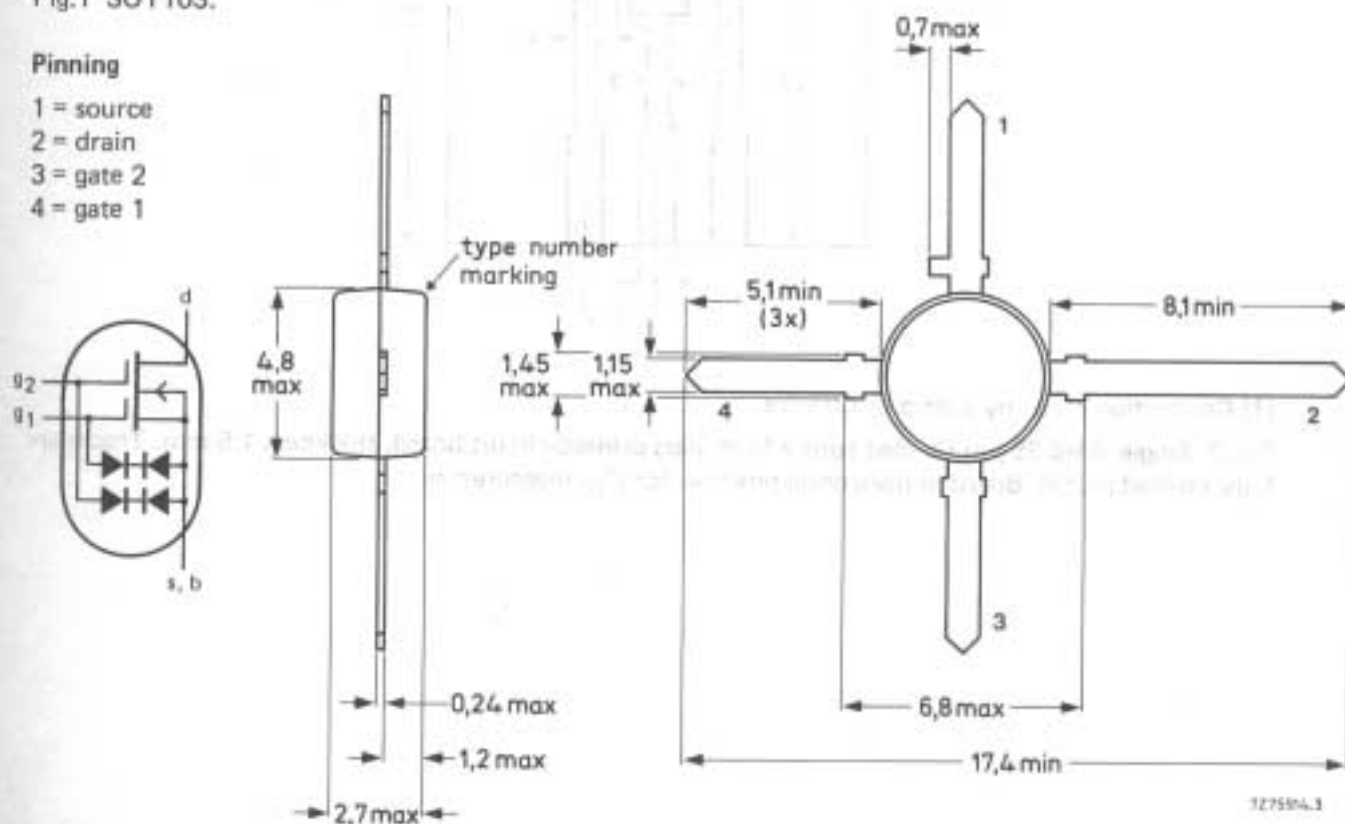

1275594.1

RATINGS

Limiting values in accordance with the Absolute Maximum System (IEC 134)

Drain-source voltage	V_{DS}	max.	20 V
Drain current (DC or average)	I_D	max.	40 mA
Gate 1 - source current	$\pm I_{G1-S}$	max.	10 mA
Gate 2 - source current	$\pm I_{G2-S}$	max.	10 mA
Total power dissipation up to $T_{amb} = 75\text{ }^{\circ}\text{C}$	P_{tot}	max.	225 mW
Storage temperature range	T_{stg}	-65 to +150	$^{\circ}\text{C}$
Junction temperature	T_j	max.	150 $^{\circ}\text{C}$

THERMAL RESISTANCE

From junction to ambient in free air
mounted on the printed-circuit board (see Fig. 2)

$$R_{thj-a} = 335\text{ K/W}$$

Dimensions in mm

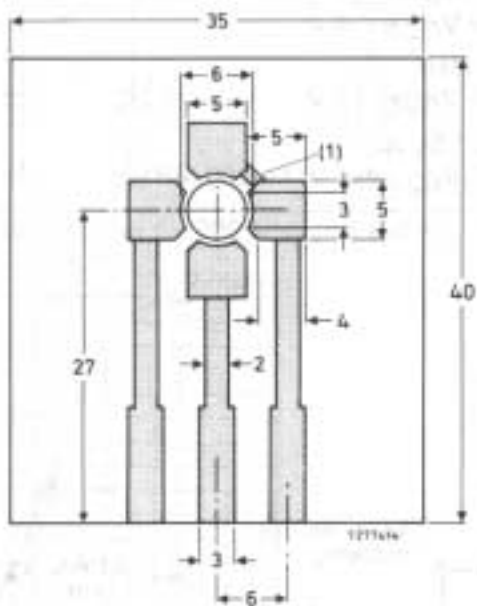

(1) Connection made by a strip or Cu wire.

Fig. 2 Single-sided 35 μm Cu-clad epoxy fibre-glass printed-circuit board, thickness 1,5 mm. Tracks are fully tin-lead plated. Board in horizontal position for R_{th} measurement.

STATIC CHARACTERISTICS

 $T_j = 25\text{ }^\circ\text{C}$

Gate cut-off currents

 $\pm V_{G1-S} = 7\text{ V}; V_{G2-S} = V_{DS} = 0$ $\pm I_{G1-SS} < 25\text{ nA}$ $\pm V_{G2-S} = 7\text{ V}; V_{G1-S} = V_{DS} = 0$ $\pm I_{G2-SS} < 25\text{ nA}$

Gate-source breakdown voltages

 $\pm I_{G1-SS} = 10\text{ mA}; V_{G2-S} = V_{DS} = 0$ $\pm V_{(BR)G1-SS} > 8\text{ to }20\text{ V}$ $\pm I_{G2-SS} = 10\text{ mA}; V_{G1-S} = V_{DS} = 0$ $\pm V_{(BR)G2-SS} > 8\text{ to }20\text{ V}$

Gate-source cut-off voltages

 $I_D = 20\text{ }\mu\text{A}; V_{DS} = 10\text{ V}; +V_{G2-S} = 4\text{ V}$ $-V_{(P)G1-S} < 1.3\text{ V}$ $I_D = 20\text{ }\mu\text{A}; V_{DS} = 10\text{ V}; V_{G1-S} = 0$ $-V_{(P)G2-S} < 1.1\text{ V}$

DYNAMIC CHARACTERISTICS

Measuring conditions (common source): $I_D = 15\text{ mA}; V_{DS} = 10\text{ V}; +V_{G2-S} = 4\text{ V}; T_{amb} = 25\text{ }^\circ\text{C}$ Transfer admittance at $f = 1\text{ kHz}$ $|y_{fs}| > 20\text{ mS}$
typ. 25 mSInput capacitance at gate 1; $f = 1\text{ MHz}$ C_{ig1-s} typ. 4.0 pFInput capacitance at gate 2; $f = 1\text{ MHz}$ C_{ig2-s} typ. 1.7 pFFeedback capacitance at $f = 1\text{ MHz}$ C_{rs} typ. 30 fFOutput capacitance at $f = 1\text{ MHz}$ C_{os} typ. 2.0 pFNoise figure at $f = 200\text{ MHz}; G_S = 2\text{ mS}; B_S = B_S\text{ opt}$

F typ. 1.2 dB